

BOX BSTB



BOX FAN WITH BACKWARD IMPELLER AND BELT TRANSMISSION - F400-120

MANUFACTURING FEATURES:

- BSTB range fans assembled in soundproof cabinets with insulated panels.
- Fan assembled on antivibration mountings.
- Simple inlet backward curved impeller.
- Supplied with motor, pulleys and belts.
- Interchangeable panels to allow different fan positions.
- Gland connection included.
- Standard asynchronous squirrel-cage motor with IP-55 protection and Class F insulation. Manufactured with standard voltages: 230/400V 50Hz in three phase motors up to 4kW and 400/690V 50Hz for higher powers.

Accessories



BA-400



FILTRO
EMC



INT



INT 400



JE-45



SFC

APPLICATIONS:

- Designed for inline installation, indoor or outdoor assembly, they are suitable for:
- Smoke emergency exhaust with motor outside the hazardous area.
 - Industrial and professional kitchen hoods.
 - Maximum working temperature: carried air: 130°C, ambient: 60°C.

UNDER REQUEST:

- 2 speed motors.
- Orientation:
 - LG90 (horizontal).
 - LG0 (vertical outlet).
- Sandwich insulation.
- 60Hz fans and special voltages.

Official homologation by the European laboratory APPLUS according to EN 12101-3:2002, EN 12101-3:2002/AC:2005
 Certification Nr: 0370-CPR-1371

Technical data

Three-phase motor

Code	Model	R.P.M.	Rated I. (A) 400V	Rated power kW	Max. Airflow m3/h	Sound db (A)*	Weight	Connect. diagram
244350110R__	BOX BSTB 355 0,37kW	1300	1,07	0,37	3.350	49	122	1
244350111R__	BOX BSTB 355 0,55kW	1500	1,49	0,55	3.830	53	125	1
244350112R__	BOX BSTB 355 0,75kW	1700	1,63	0,75	4.310	55	126	1
244350113R__	BOX BSTB 355 1,1kW	1900	2,49	1,10	4.780	58	128	1
244350114R__	BOX BSTB 355 1,5kW	2100	3,26	1,50	5.260	60	131	1
244350115R__	BOX BSTB 355 2,2kW	2300	4,64	2,20	6.130	62	137	1
244350116R__	BOX BSTB 355 3kW	2600	6,17	3	6.690	65	141	1
244400110R__	BOX BSTB 400 0,55kW	1200	1,49	0,55	4.750	54	161	1
244400111R__	BOX BSTB 400 0,75kW	1400	1,63	0,75	5.120	58	162	1
244400112R__	BOX BSTB 400 1,1kW	1500	2,49	1,10	5.850	60	164	1
244400113R__	BOX BSTB 400 1,5kW	1700	3,26	1,50	6.580	62	167	1
244400114R__	BOX BSTB 400 2,2kW	1900	4,64	2,20	7.310	65	173	1
244400115R__	BOX BSTB 400 3kW	2100	6,17	3	8.400	67	177	1
244400116R__	BOX BSTB 400 4kW	2400	8,32	4	9.130	70	183	1
244450110R__	BOX BSTB 450 0,75kW	1200	1,63	0,75	5.950	59	190	1
244450111R__	BOX BSTB 450 1,1kW	1200	2,49	1,10	6.520	59	192	1
244450112R__	BOX BSTB 450 1,5kW	1400	3,26	1,50	7.520	63	195	1
244450113R__	BOX BSTB 450 2,2kW	1600	4,64	2,20	8.520	66	201	1
244450114R__	BOX BSTB 450 3kW	1800	6,17	3	9.520	69	205	1
244450115R__	BOX BSTB 450 4kW	2000	8,32	4	10.310	71	211	1
244450116R__	BOX BSTB 450 5,5kW	2100	10,5	5,50	11.520	72	220	1
244450117R__	BOX BSTB 450 7,5kW	2400	14,1	7,50	12.520	75	230	1
244500110R__	BOX BSTB 500 1,1kW	900	2,49	1,10	7.500	54	219	1
244500111R__	BOX BSTB 500 1,5kW	1200	3,26	1,50	8.180	61	222	1
244500112R__	BOX BSTB 500 2,2kW	1300	4,64	2,20	9.540	63	228	1
244500113R__	BOX BSTB 500 3kW	1500	6,17	3	10.900	66	232	1
244500114R__	BOX BSTB 500 4kW	1700	8,32	4	11.580	69	238	1
244500115R__	BOX BSTB 500 5,5kW	1800	10,5	5,50	12.950	70	247	1
244500116R__	BOX BSTB 500 7,5kW	2000	14,1	7,50	19.750	72	257	1
244560110R__	BOX BSTB 560 1,5kW	800	3,26	1,50	9.610	56	250	1
244560111R__	BOX BSTB 560 2,2kW	1200	4,64	2,20	10.480	65	256	1
244560112R__	BOX BSTB 560 3kW	1300	6,17	3	12.230	67	260	1
244560113R__	BOX BSTB 560 4kW	1500	8,32	4	13.100	70	266	1
244560114R__	BOX BSTB 560 5,5kW	1600	10,5	5,50	14.850	72	275	1
244560115R__	BOX BSTB 560 7,5kW	1800	14,1	7,50	16.590	74	285	1

Code	Model	R.P.M.	Rated I. (A) 400V	Rated power kW	Max. Airflow m3/h	Sound db (A)*	Weight	Connect. diagram
244560116R__	BOX BSTB 560 11kW	2000	21,2	11	18.340	77	299	1
244630110R__	BOX BSTB 630 2,2kW	800	4,64	2,20	11.510	58	296	1
244630111R__	BOX BSTB 630 3kW	1000	6,17	3	12.900	63	300	1
244630112R__	BOX BSTB 630 4kW	1100	8,32	4	15.010	66	306	1
244630113R__	BOX BSTB 630 5,5kW	1200	10,5	5,50	16.630	68	315	1
244630114R__	BOX BSTB 630 7,5kW	1400	14,1	7,50	17.900	71	325	1
244630115R__	BOX BSTB 630 11kW	1500	21,2	11	20.460	73	339	1
244630116R__	BOX BSTB 630 15kW	1700	29,8	15	23.020	76	417	1
244710110R__	BOX BSTB 710 3kW	600	6,17	3	14.700	54	330	1
244710111R__	BOX BSTB 710 4kW	900	8,32	4	16.520	63	336	1
244710112R__	BOX BSTB 710 5,5kW	1000	10,5	5,50	18.360	65	345	1
244710113R__	BOX BSTB 710 7,5kW	1100	14,1	7,50	22.030	68	355	1
244710114R__	BOX BSTB 710 11kW	1300	20,9	11	23.860	71	369	1
244710115R__	BOX BSTB 710 15kW	1400	27,9	15	27.530	73	447	1
244710116R__	BOX BSTB 710 18,5kW	1600	33	18,50	29.370	76	479	1

Notes:

* Total sound pressure level at the point of maximum flow measured in dB(A) in the suction measured in free field at a distance of 6m from the source

Dimensions

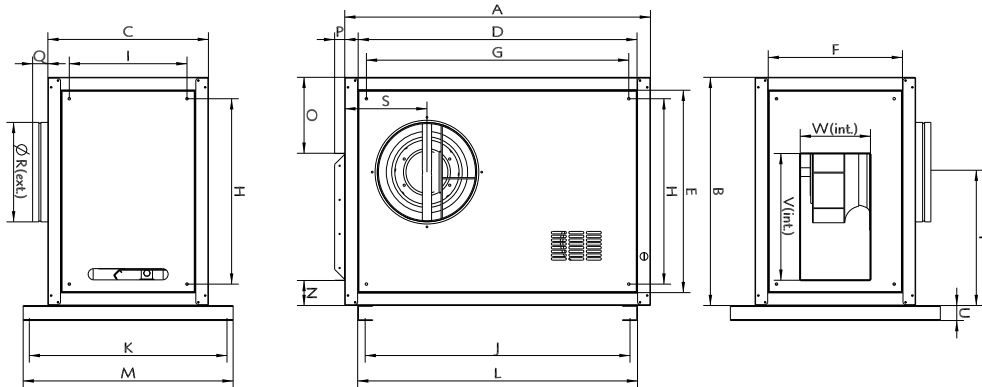

Model	A	B	C	D	E	F	G	H	I
BOX BSTB 355 0,37kW	1068	824	612	960,5	721	506	894,5	652,5	440
BOX BSTB 355 0,55kW	1068	824	612	960,5	721	506	894,5	652,5	440
BOX BSTB 355 0,75kW	1068	824	612	960,5	721	506	894,5	652,5	440
BOX BSTB 355 1,1kW	1068	824	612	960,5	721	506	894,5	652,5	440
BOX BSTB 355 1,5kW	1068	824	612	960,5	721	506	894,5	652,5	440
BOX BSTB 355 2,2kW	1068	824	612	960,5	721	506	894,5	652,5	440
BOX BSTB 355 3kW	1068	824	612	960,5	721	506	894,5	652,5	440
BOX BSTB 400 0,55kW	1223	913	642	1117	809	536	1049,5	741,5	471
BOX BSTB 400 0,75kW	1223	913	642	1117	809	536	1049,5	741,5	471
BOX BSTB 400 1,1kW	1223	913	642	1117	809	536	1049,5	741,5	471
BOX BSTB 400 1,5kW	1223	913	642	1117	809	536	1049,5	741,5	471
BOX BSTB 400 2,2kW	1223	913	642	1117	809	536	1049,5	741,5	471
BOX BSTB 400 3kW	1223	913	642	1117	809	536	1049,5	741,5	471
BOX BSTB 400 4kW	1223	913	642	1117	809	536	1049,5	741,5	471
BOX BSTB 450 0,75kW	1323	1003	692	1215,7	900	587	1149,5	831,5	521
BOX BSTB 450 1,1kW	1323	1003	692	1215,7	900	587	1149,5	831,5	521
BOX BSTB 450 1,5kW	1323	1003	692	1215,7	900	587	1149,5	831,5	521
BOX BSTB 450 2,2kW	1323	1003	692	1215,7	900	587	1149,5	831,5	521
BOX BSTB 450 3kW	1323	1003	692	1215,7	900	587	1149,5	831,5	521
BOX BSTB 450 4kW	1323	1003	692	1215,7	900	587	1149,5	831,5	521
BOX BSTB 450 5,5kW	1323	1003	692	1215,7	900	587	1149,5	831,5	521
BOX BSTB 450 7,5kW	1323	1003	692	1215,7	900	587	1149,5	831,5	521
BOX BSTB 500 1,1kW	1423	1100	732	1315,7	997	627	1249,5	928,5	561
BOX BSTB 500 1,5kW	1423	1100	732	1315,7	997	627	1249,5	928,5	561
BOX BSTB 500 2,2kW	1423	1100	732	1315,7	997	627	1249,5	928,5	561
BOX BSTB 500 3kW	1423	1100	732	1315,7	997	627	1249,5	928,5	561
BOX BSTB 500 4kW	1423	1100	732	1315,7	997	627	1249,5	928,5	561

Model	A	B	C	D	E	F	G	H	I
BOX BSTB 500 5,5kW	1423	1100	732	1315,7	997	627	1249,5	928,5	561
BOX BSTB 500 7,5kW	1423	1100	732	1315,7	997	627	1249,5	928,5	561

Model	J	K	L	M	N	O	P	Q	S
BOX BSTB 355 0,37kW	904,5	760	964,5	809	101	268	40,5	60	307
BOX BSTB 355 0,55kW	904,5	760	964,5	809	101	268	40,5	60	307
BOX BSTB 355 0,75kW	904,5	760	964,5	809	101	268	40,5	60	307
BOX BSTB 355 1,1kW	904,5	760	964,5	809	101	268	40,5	60	307
BOX BSTB 355 1,5kW	904,5	760	964,5	809	101	268	40,5	60	307
BOX BSTB 355 2,2kW	904,5	760	964,5	809	101	268	40,5	60	307
BOX BSTB 355 3kW	904,5	760	964,5	809	101	268	40,5	60	307
BOX BSTB 400 0,55kW	1059,5	791	1119,5	840	100	304	40,5	60	329
BOX BSTB 400 0,75kW	1059,5	791	1119,5	840	100	304	40,5	60	329
BOX BSTB 400 1,1kW	1059,5	791	1119,5	840	100	304	40,5	60	329
BOX BSTB 400 1,5kW	1059,5	791	1119,5	840	100	304	40,5	60	329
BOX BSTB 400 2,2kW	1059,5	791	1119,5	840	100	304	40,5	60	329
BOX BSTB 400 3kW	1059,5	791	1119,5	840	100	304	40,5	60	329
BOX BSTB 400 4kW	1059,5	791	1119,5	840	100	304	40,5	60	329
BOX BSTB 450 0,75kW	1159,5	841	1219,5	890	100	328	40,5	60	375
BOX BSTB 450 1,1kW	1159,5	841	1219,5	890	100	328	40,5	60	375
BOX BSTB 450 1,5kW	1159,5	841	1219,5	890	100	328	40,5	60	375
BOX BSTB 450 2,2kW	1159,5	841	1219,5	890	100	328	40,5	60	375
BOX BSTB 450 3kW	1159,5	841	1219,5	890	100	328	40,5	60	375
BOX BSTB 450 4kW	1159,5	841	1219,5	890	100	328	40,5	60	375
BOX BSTB 450 5,5kW	1159,5	841	1219,5	890	100	328	40,5	60	375
BOX BSTB 450 7,5kW	1159,5	841	1219,5	890	100	328	40,5	60	375
BOX BSTB 500 1,1kW	1259,5	881	1319,5	930	104	355	40,5	60	399
BOX BSTB 500 1,5kW	1259,5	881	1319,5	930	104	355	40,5	60	399
BOX BSTB 500 2,2kW	1259,5	881	1319,5	930	104	355	40,5	60	399
BOX BSTB 500 3kW	1259,5	881	1319,5	930	104	355	40,5	60	399
BOX BSTB 500 4kW	1259,5	881	1319,5	930	104	355	40,5	60	399
BOX BSTB 500 5,5kW	1259,5	881	1319,5	930	104	355	40,5	60	399
BOX BSTB 500 7,5kW	1259,5	881	1319,5	930	104	355	40,5	60	399

Model	T	U	V	W	ØR
BOX BSTB 355 0,37kW	485,7	60	453	253	353
BOX BSTB 355 0,55kW	485,7	60	453	253	353
BOX BSTB 355 0,75kW	485,7	60	453	253	353
BOX BSTB 355 1,1kW	485,7	60	453	253	353
BOX BSTB 355 1,5kW	485,7	60	453	253	353



Model	T	U	V	W	ØR
BOX BSTB 355 2,2kW	485,7	60	453	253	353
BOX BSTB 355 3kW	485,7	60	453	253	353
BOX BSTB 400 0,55kW	533,7	60	507	281	398
BOX BSTB 400 0,75kW	533,7	60	507	281	398
BOX BSTB 400 1,1kW	533,7	60	507	281	398
BOX BSTB 400 1,5kW	533,7	60	507	281	398
BOX BSTB 400 2,2kW	533,7	60	507	281	398
BOX BSTB 400 3kW	533,7	60	507	281	398
BOX BSTB 400 4kW	533,7	60	507	281	398
BOX BSTB 450 0,75kW	587,7	60	573	310	448
BOX BSTB 450 1,1kW	587,7	60	573	310	448
BOX BSTB 450 1,5kW	587,7	60	573	310	448
BOX BSTB 450 2,2kW	587,7	60	573	310	448
BOX BSTB 450 3kW	587,7	60	573	310	448
BOX BSTB 450 4kW	587,7	60	573	310	448
BOX BSTB 450 5,5kW	587,7	60	573	310	448
BOX BSTB 450 7,5kW	587,7	60	573	310	448
BOX BSTB 500 1,1kW	643,7	60	639	341	498
BOX BSTB 500 1,5kW	643,7	60	639	341	498
BOX BSTB 500 2,2kW	643,7	60	639	341	498
BOX BSTB 500 3kW	643,7	60	639	341	498
BOX BSTB 500 4kW	643,7	60	639	341	498
BOX BSTB 500 5,5kW	643,7	60	639	341	498
BOX BSTB 500 7,5kW	643,7	60	639	341	498

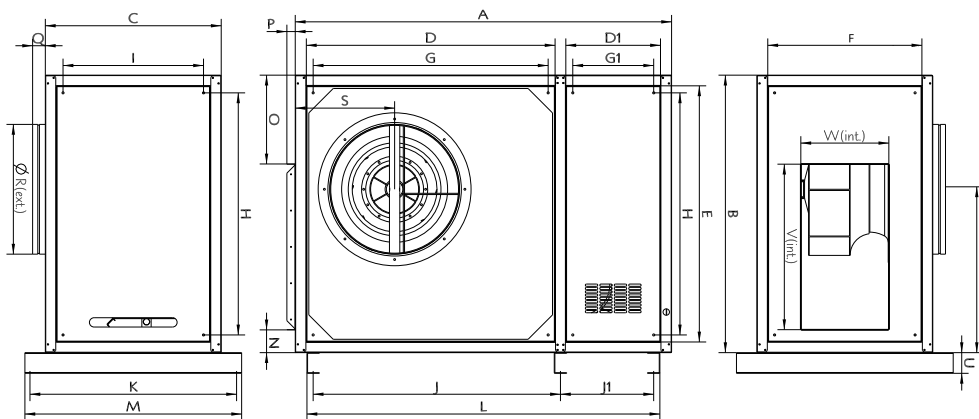

Model	A	B	C	D	D1	E	F	G	G1
BOX BSTB 560 1,5kW	1691,5	1216	801,3	1071	461,3	1112,8	696	1004,4	394,6

Model	A	B	C	D	D1	E	F	G	G1
BOX BSTB 560 2,2kW	1691,5	1216	801,3	1071	461,3	1112,8	696	1004,4	394,6
BOX BSTB 560 3kW	1691,5	1216	801,3	1071	461,3	1112,8	696	1004,4	394,6
BOX BSTB 560 4kW	1691,5	1216	801,3	1071	461,3	1112,8	696	1004,4	394,6
BOX BSTB 560 5,5kW	1691,5	1216	801,3	1071	461,3	1112,8	696	1004,4	394,6
BOX BSTB 560 7,5kW	1691,5	1216	801,3	1071	461,3	1112,8	696	1004,4	394,6
BOX BSTB 560 11kW	1691,5	1216	801,3	1071	461,3	1112,8	696	1004,4	394,6
BOX BSTB 630 2,2kW	1821,5	1343	851	1204,5	458,8	1238,7	745	1137,4	391,6
BOX BSTB 630 3kW	1821,5	1343	851	1204,5	458,8	1238,7	745	1137,4	391,6
BOX BSTB 630 4kW	1821,5	1343	851	1204,5	458,8	1238,7	745	1137,4	391,6
BOX BSTB 630 5,5kW	1821,5	1343	851	1204,5	458,8	1238,7	745	1137,4	391,6
BOX BSTB 630 7,5kW	1821,5	1343	851	1204,5	458,8	1238,7	745	1137,4	391,6
BOX BSTB 630 11kW	1821,5	1343	851	1204,5	458,8	1238,7	745	1137,4	391,6
BOX BSTB 630 15kW	1821,5	1343	851	1204,5	458,8	1238,7	745	1137,4	391,6
BOX BSTB 710 3kW	1988	1488	912	1326,8	503	1383,7	805	1259,7	435,9
BOX BSTB 710 4kW	1988	1488	912	1326,8	503	1383,7	805	1259,7	435,9
BOX BSTB 710 5,5kW	1988	1488	912	1326,8	503	1383,7	805	1259,7	435,9
BOX BSTB 710 7,5kW	1988	1488	912	1326,8	503	1383,7	805	1259,7	435,9
BOX BSTB 710 11kW	1988	1488	912	1326,8	503	1383,7	805	1259,7	435,9
BOX BSTB 710 15kW	1988	1488	912	1326,8	503	1383,7	805	1259,7	435,9
BOX BSTB 710 18,5kW	1988	1488	912	1326,8	503	1383,7	805	1259,7	435,9

Model	H	I	J	J1	K	L	M	N	O
BOX BSTB 560 1,5kW	1044,7	630	1064	454	950	1578	999	111	387,8
BOX BSTB 560 2,2kW	1044,7	630	1064	454	950	1578	999	111	387,8
BOX BSTB 560 3kW	1044,7	630	1064	454	950	1578	999	111	387,8
BOX BSTB 560 4kW	1044,7	630	1064	454	950	1578	999	111	387,8
BOX BSTB 560 5,5kW	1044,7	630	1064	454	950	1578	999	111	387,8
BOX BSTB 560 7,5kW	1044,7	630	1064	454	950	1578	999	111	387,8
BOX BSTB 560 11kW	1044,7	630	1064	454	950	1578	999	111	387,8
BOX BSTB 630 2,2kW	1171,7	680	1197	451	1000	1708	1049	110	430
BOX BSTB 630 3kW	1171,7	680	1197	451	1000	1708	1049	110	430
BOX BSTB 630 4kW	1171,7	680	1197	451	1000	1708	1049	110	430
BOX BSTB 630 5,5kW	1171,7	680	1197	451	1000	1708	1049	110	430
BOX BSTB 630 7,5kW	1171,7	680	1197	451	1000	1708	1049	110	430
BOX BSTB 630 11kW	1171,7	680	1197	451	1000	1708	1049	110	430
BOX BSTB 630 15kW	1171,7	680	1197	451	1000	1708	1049	110	430
BOX BSTB 710 3kW	1316,7	740	1319	495,5	1060	1874,5	1109	111	475,8
BOX BSTB 710 4kW	1316,7	740	1319	495,5	1060	1874,5	1109	111	475,8
BOX BSTB 710 5,5kW	1316,7	740	1319	495,5	1060	1874,5	1109	111	475,8
BOX BSTB 710 7,5kW	1316,7	740	1319	495,5	1060	1874,5	1109	111	475,8

Model	H	I	J	J1	K	L	M	N	O
BOX BSTB 710 11kW	1316,7	740	1319	495,5	1060	1874,5	1109	111	475,8
BOX BSTB 710 15kW	1316,7	740	1319	495,5	1060	1874,5	1109	111	475,8
BOX BSTB 710 18,5kW	1316,7	740	1319	495,5	1060	1874,5	1109	111	475,8

Model	P	Q	S	T	U	V	W	ØR
BOX BSTB 560 1,5kW	40,5	60	511	715	100	715	383	558
BOX BSTB 560 2,2kW	40,5	60	511	715	100	715	383	558
BOX BSTB 560 3kW	40,5	60	511	715	100	715	383	558
BOX BSTB 560 4kW	40,5	60	511	715	100	715	383	558
BOX BSTB 560 5,5kW	40,5	60	511	715	100	715	383	558
BOX BSTB 560 7,5kW	40,5	60	511	715	100	715	383	558
BOX BSTB 560 11kW	40,5	60	511	715	100	715	383	558
BOX BSTB 630 2,2kW	40,5	60	523	790	100	801	426	628
BOX BSTB 630 3kW	40,5	60	523	790	100	801	426	628
BOX BSTB 630 4kW	40,5	60	523	790	100	801	426	628
BOX BSTB 630 5,5kW	40,5	60	523	790	100	801	426	628
BOX BSTB 630 7,5kW	40,5	60	523	790	100	801	426	628
BOX BSTB 630 11kW	40,5	60	523	790	100	801	426	628
BOX BSTB 630 15kW	40,5	60	523	790	100	801	426	628
BOX BSTB 710 3kW	40,5	60	545	878	100	899	479	708
BOX BSTB 710 4kW	40,5	60	545	878	100	899	479	708
BOX BSTB 710 5,5kW	40,5	60	545	878	100	899	479	708
BOX BSTB 710 7,5kW	40,5	60	545	878	100	899	479	708
BOX BSTB 710 11kW	40,5	60	545	878	100	899	479	708
BOX BSTB 710 15kW	40,5	60	545	878	100	899	479	708
BOX BSTB 710 18,5kW	40,5	60	545	878	100	899	479	708

Wiring diagram

DIAGRAM Nº 1

230/400V

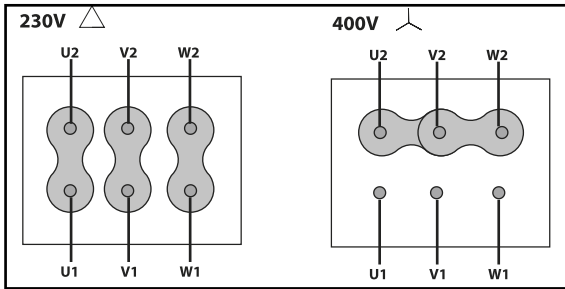

400/690V

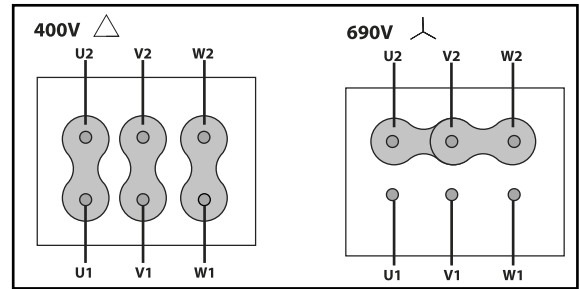

CHARACTERISCTIC CURVE

BOX BSTB 355 0,37kW

AIR FLOW - PRESSURE

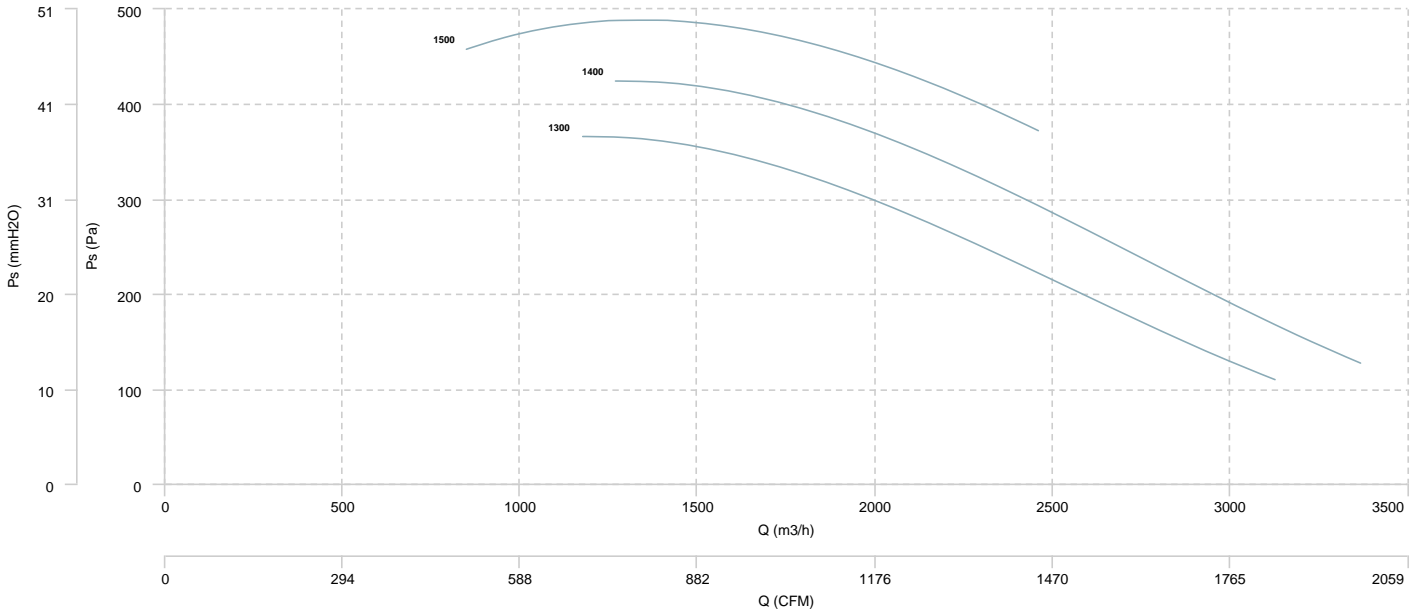

AIR FLOW - ABSORBED POWER

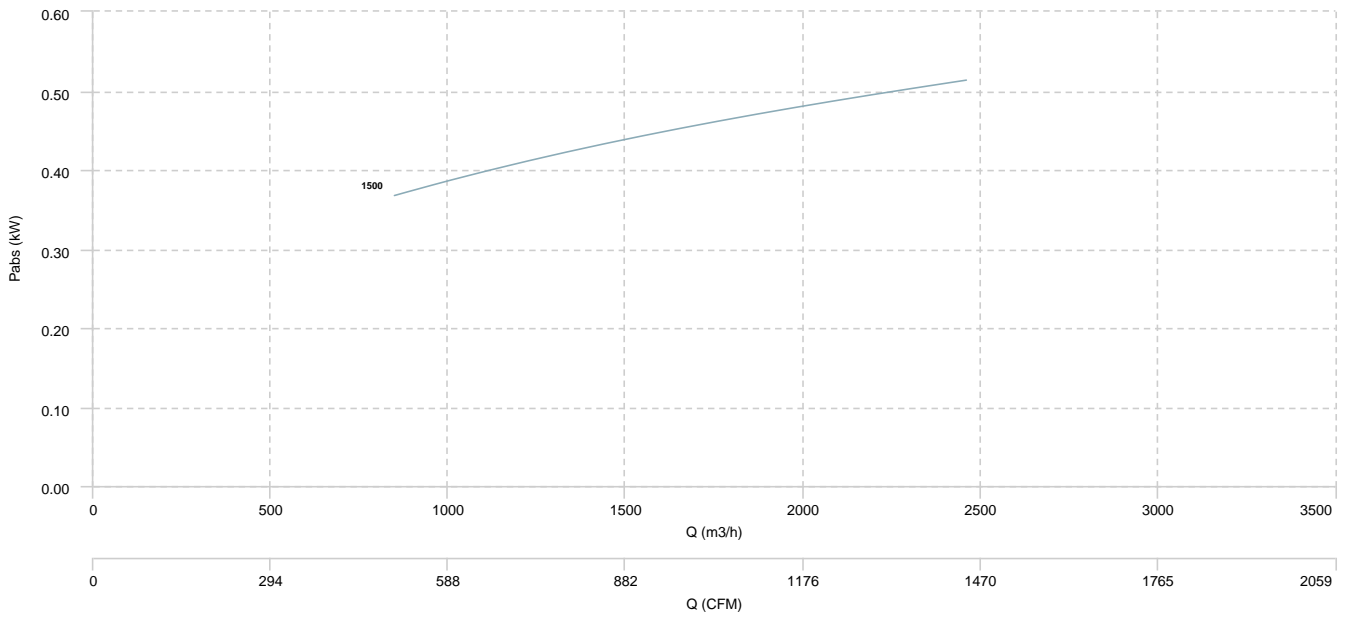

BOX BSTB 355 0,55kW

AIR FLOW - PRESSURE

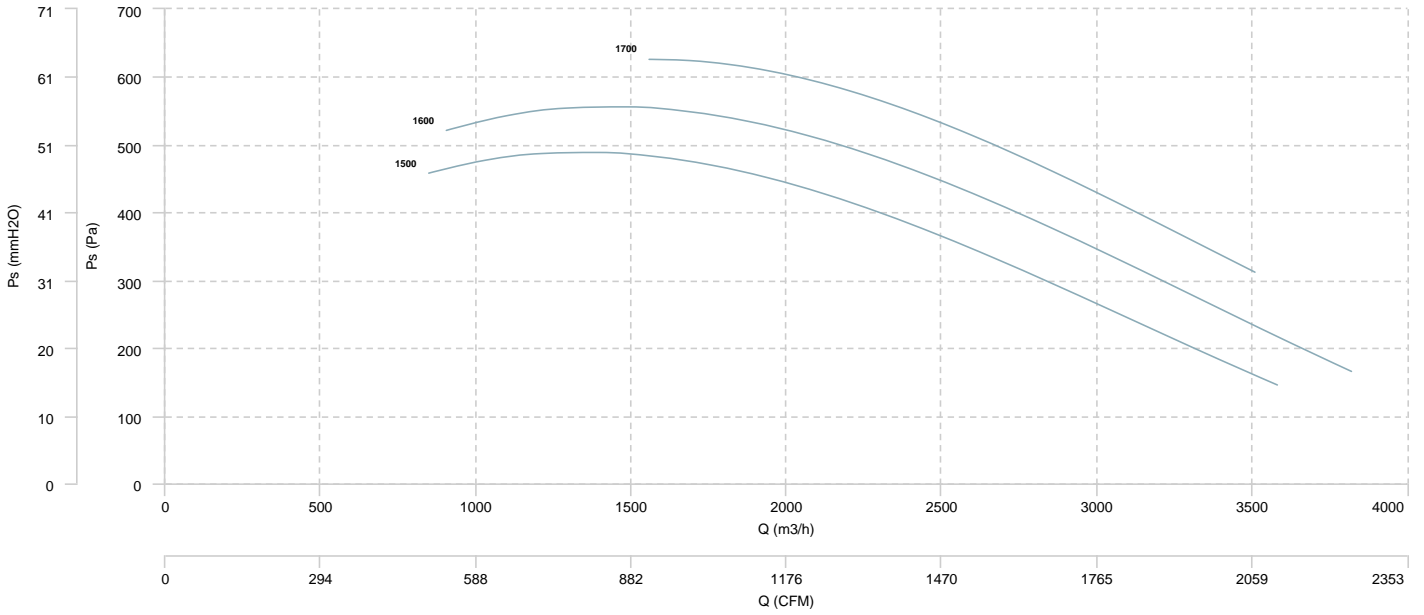

AIR FLOW - ABSORBED POWER

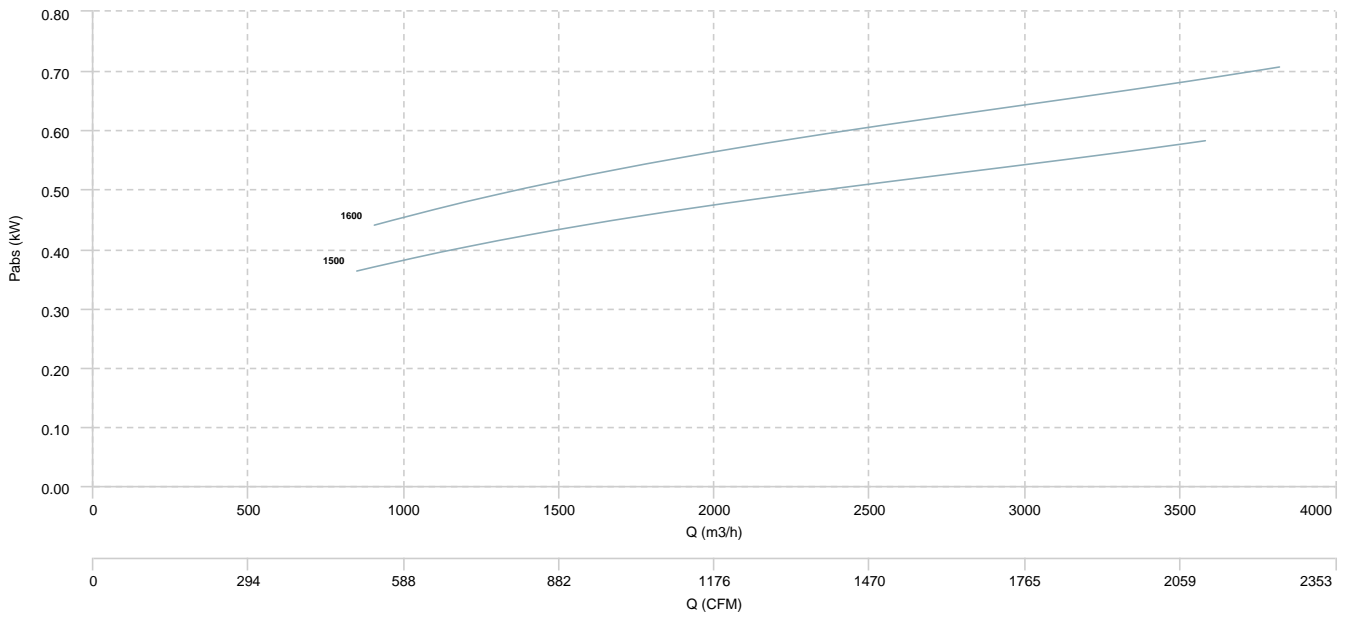

BOX BSTB 355 0,75kW

AIR FLOW - PRESSURE

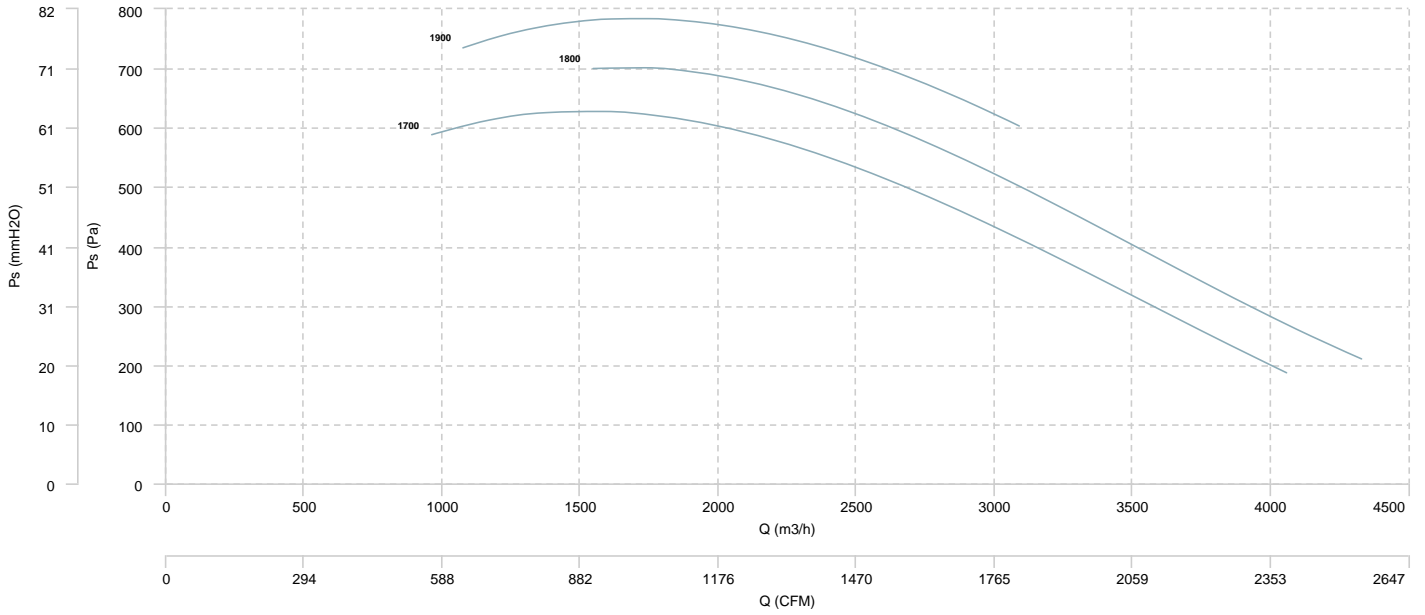

AIR FLOW - ABSORBED POWER

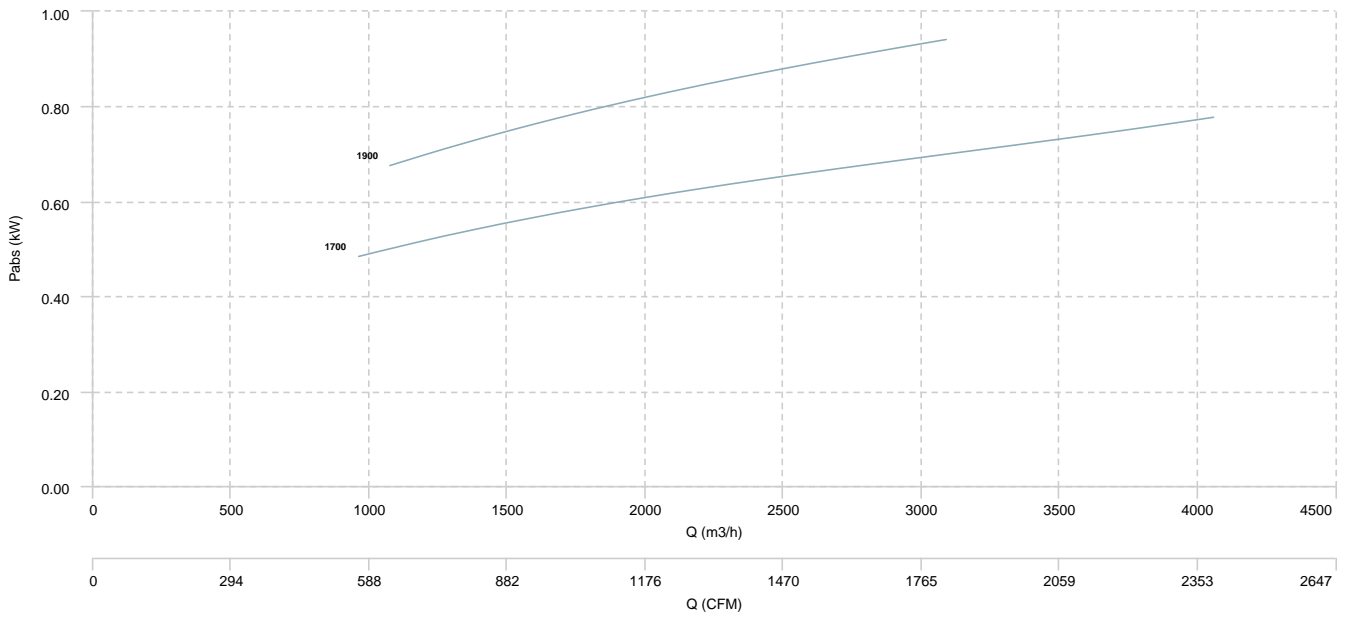

BOX BSTB 355 1,1kW

AIR FLOW - PRESSURE

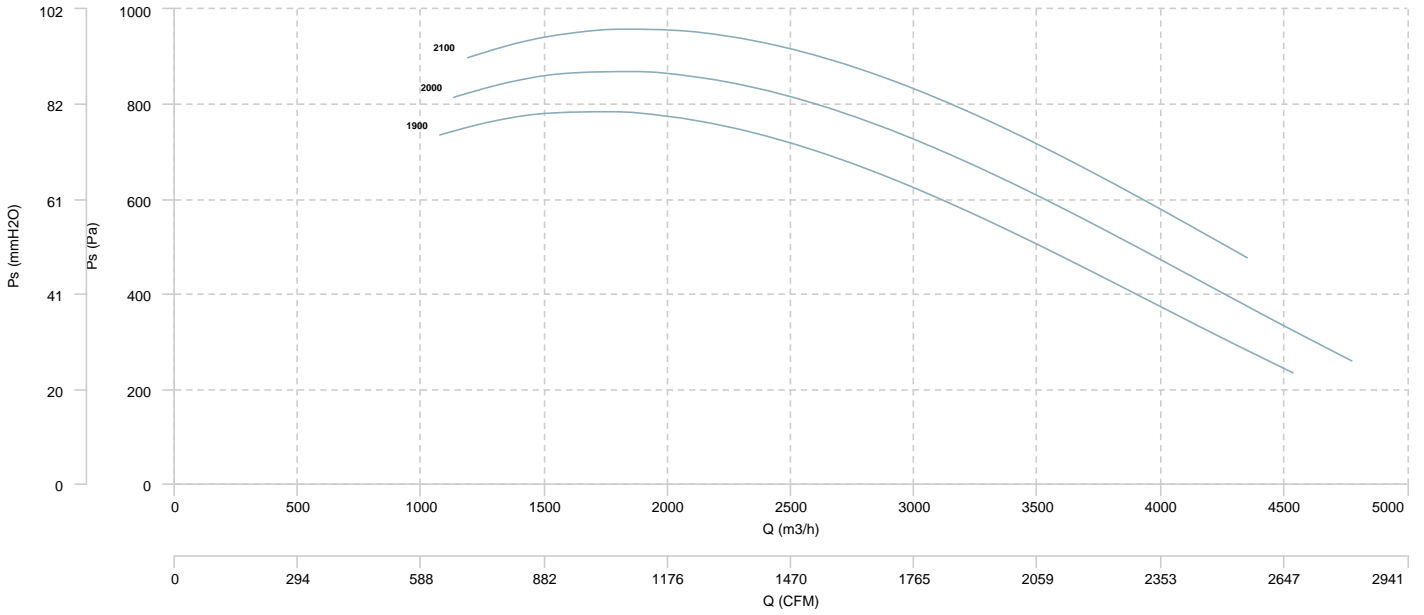

AIR FLOW - ABSORBED POWER

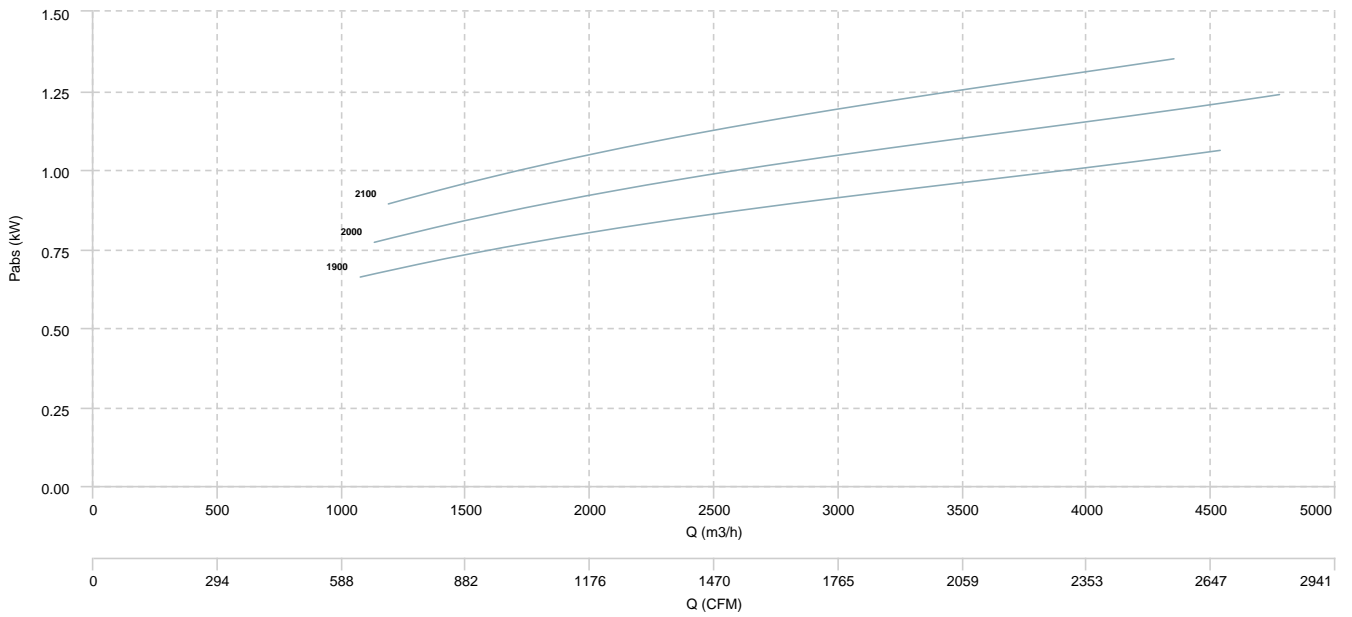

BOX BSTB 355 1,5kW

AIR FLOW - PRESSURE

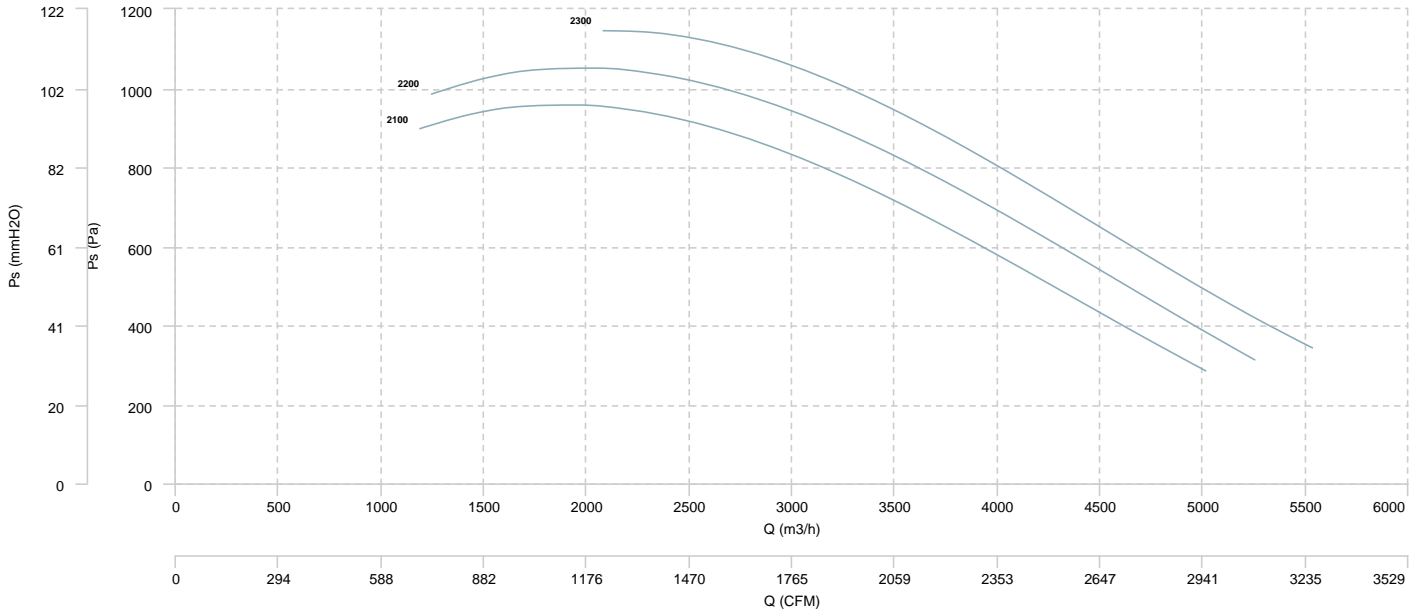

AIR FLOW - ABSORBED POWER

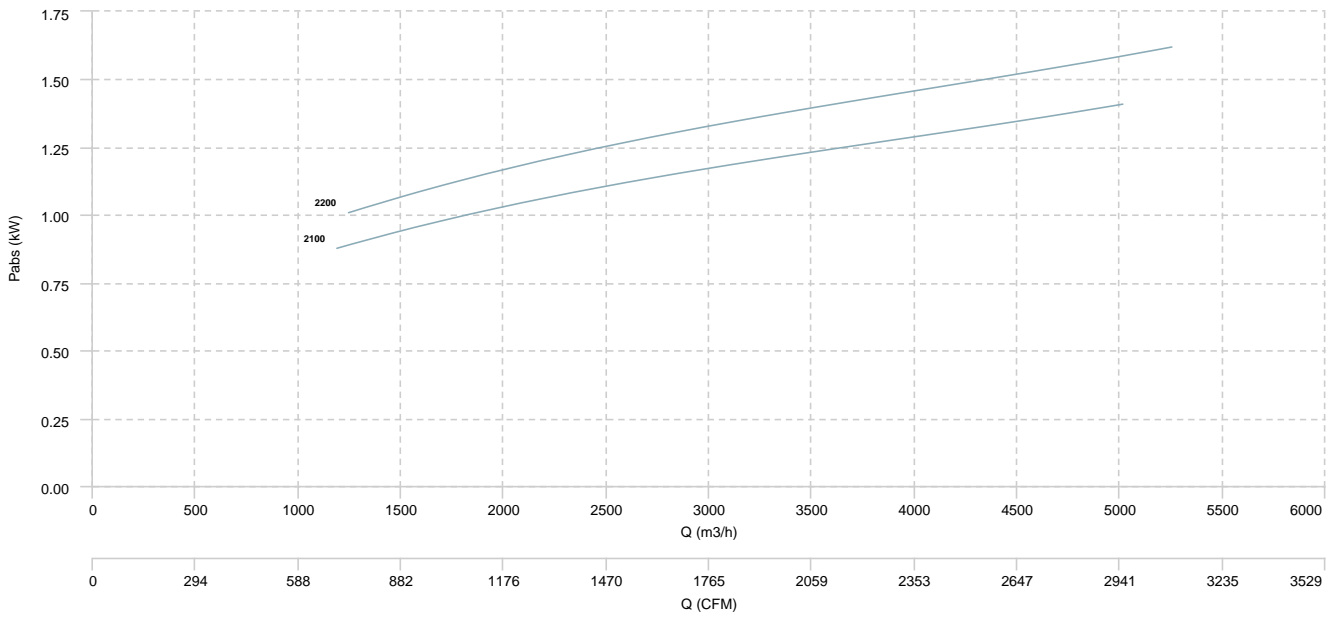

BOX BSTB 355 2,2kW

AIR FLOW - PRESSURE

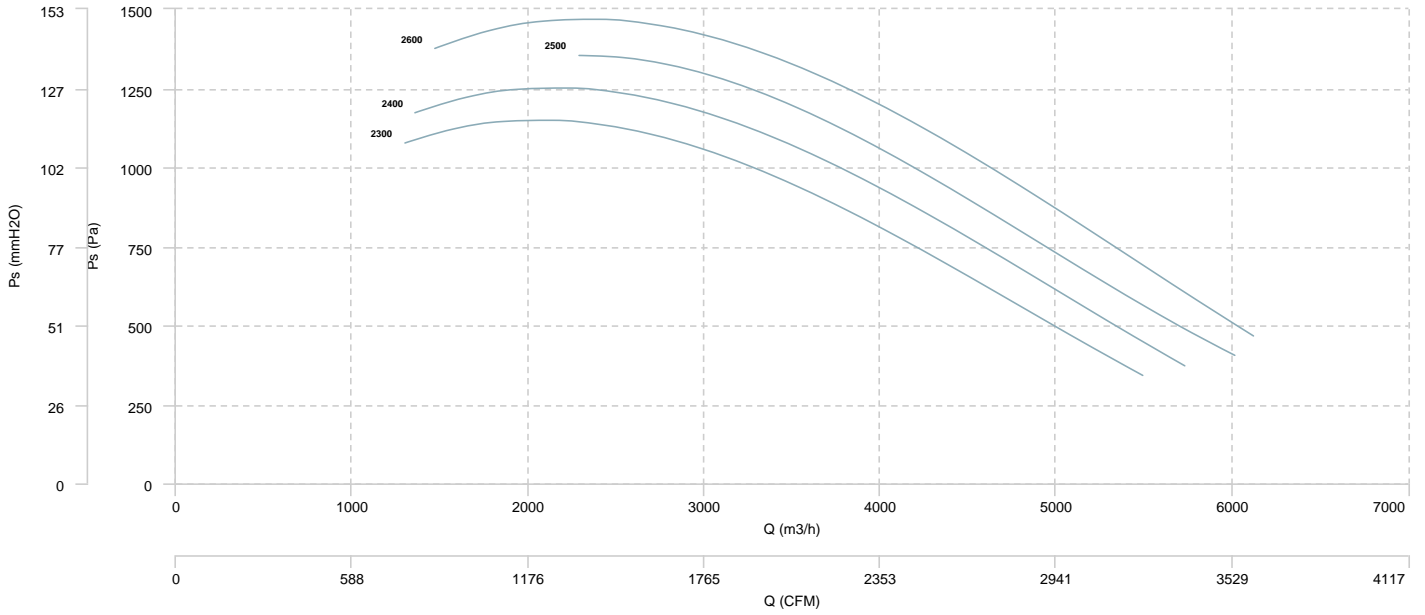

AIR FLOW - ABSORBED POWER

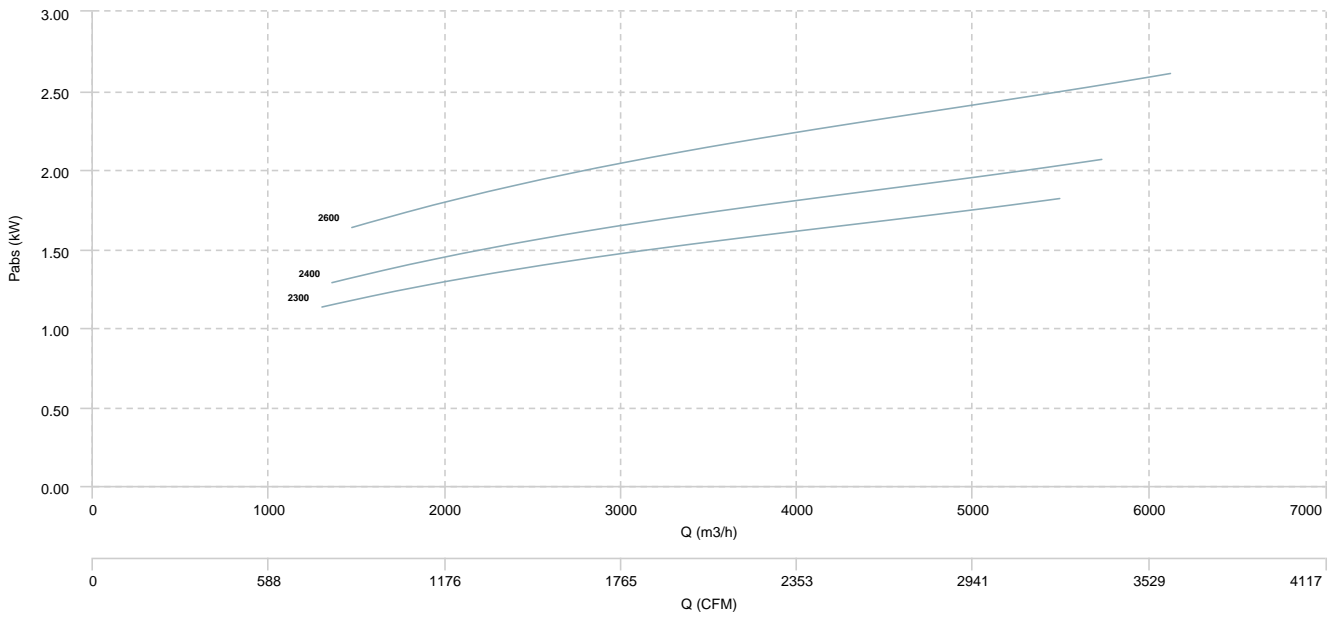

BOX BSTB 355 3kW

AIR FLOW - PRESSURE

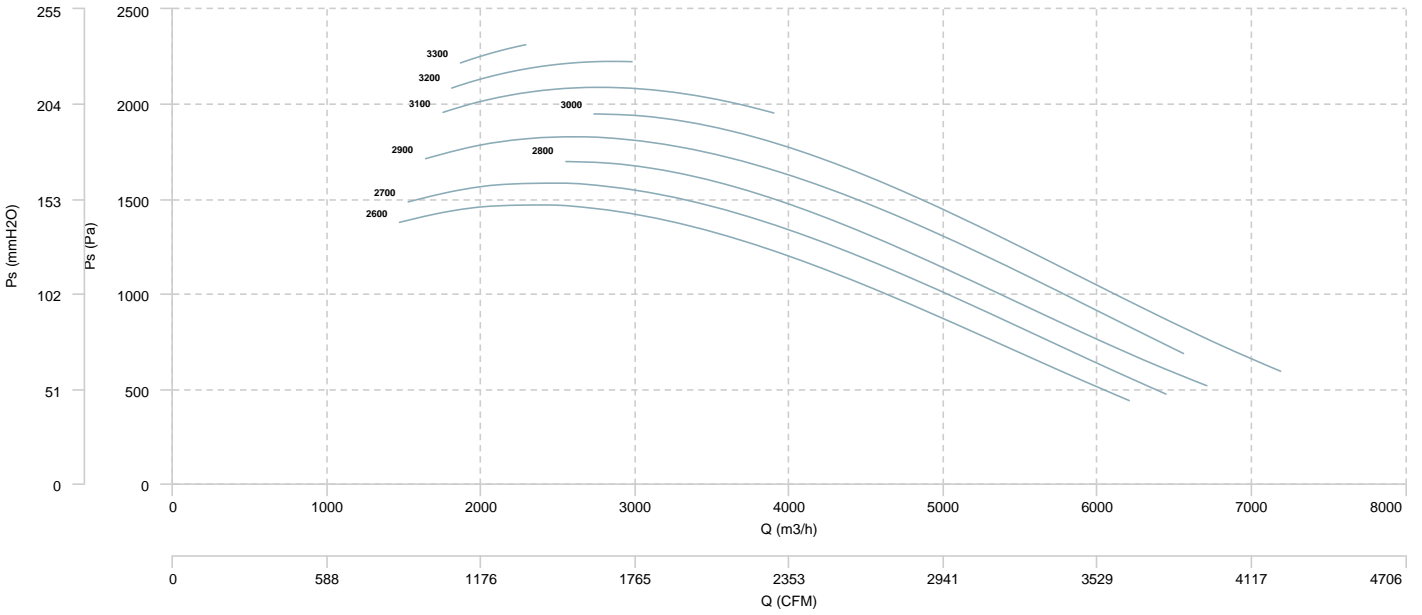

AIR FLOW - ABSORBED POWER

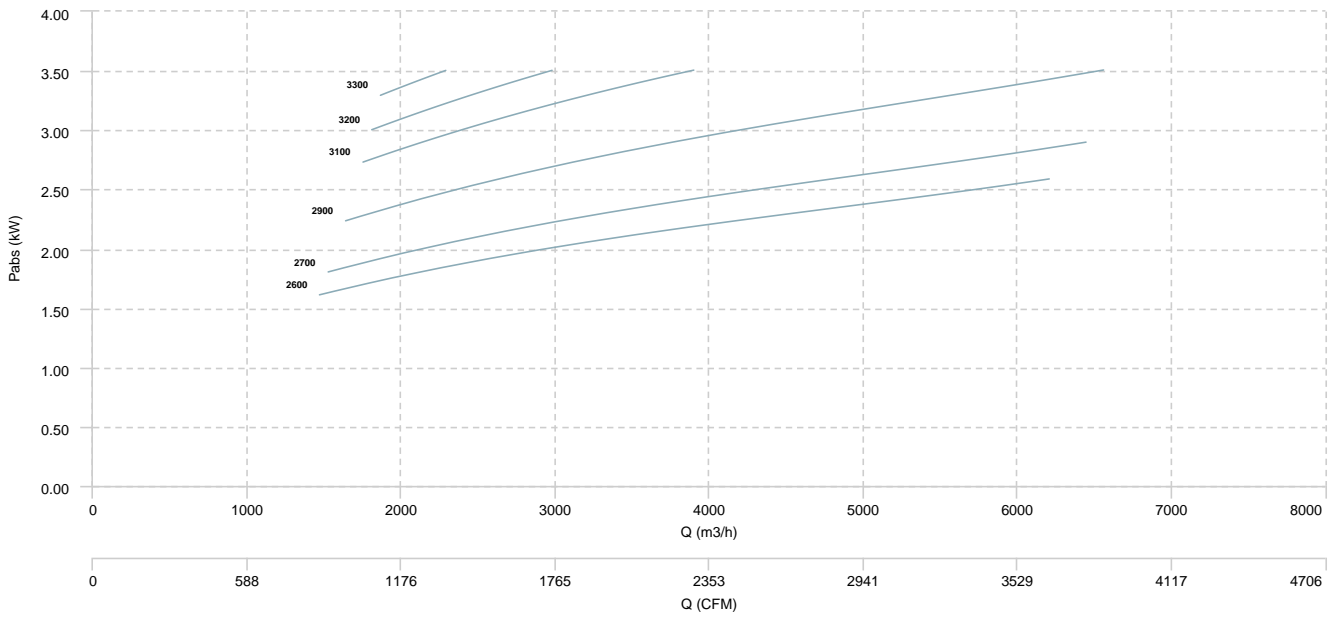

BOX BSTB 400 0,55kW

AIR FLOW - PRESSURE

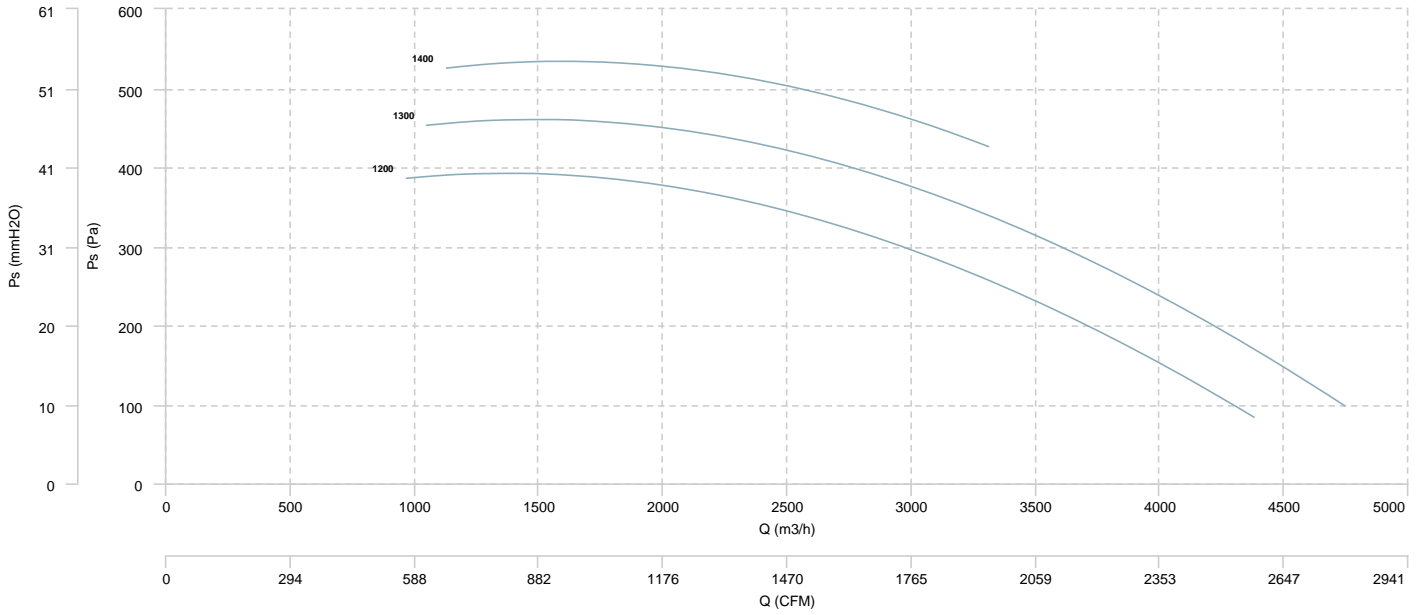

AIR FLOW - ABSORBED POWER

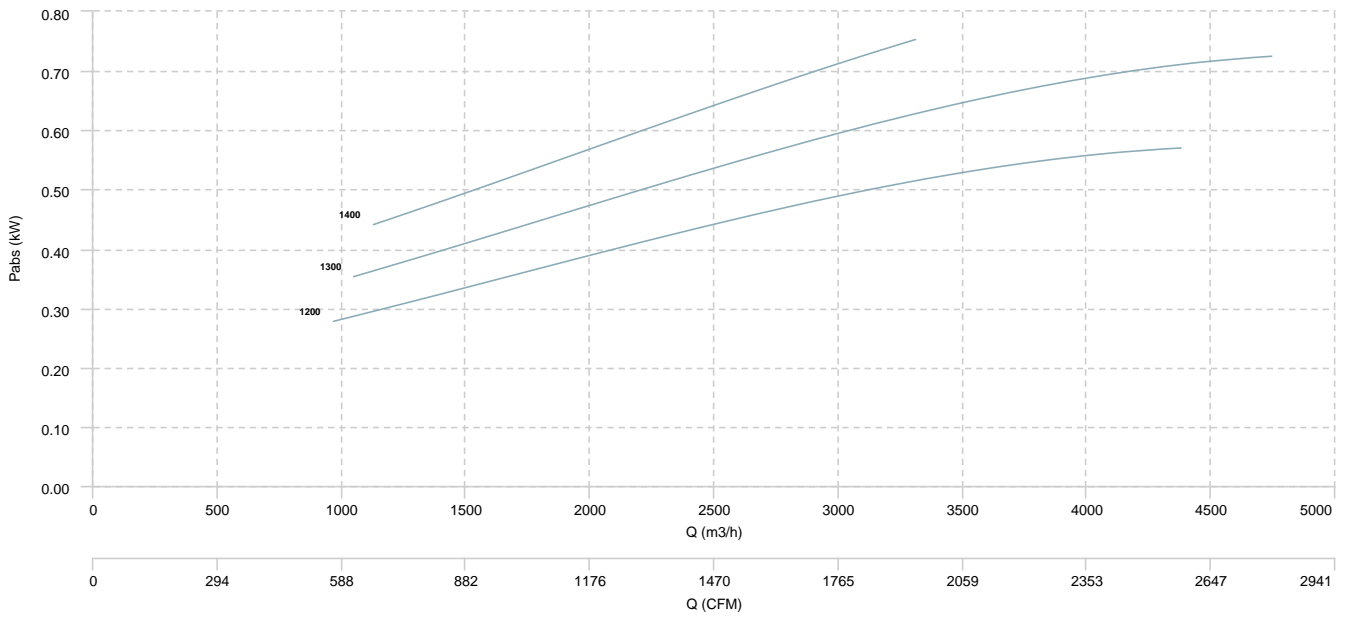

BOX BSTB 400 0,75kW

AIR FLOW - PRESSURE

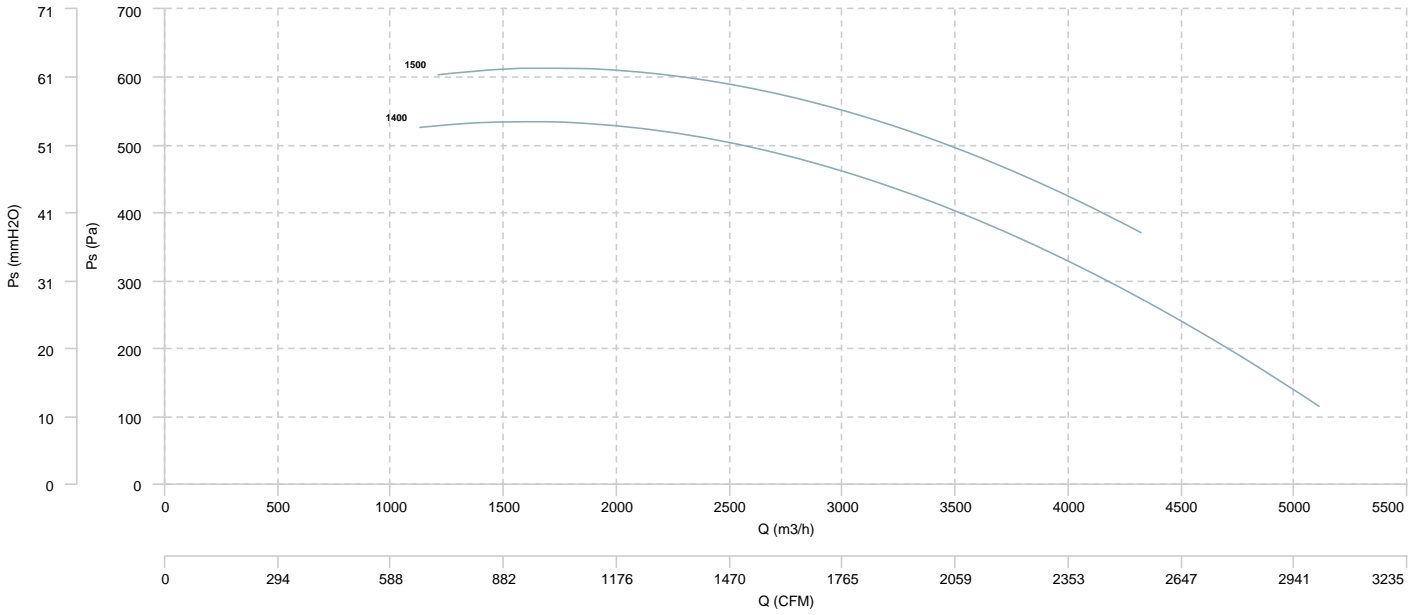

AIR FLOW - ABSORBED POWER

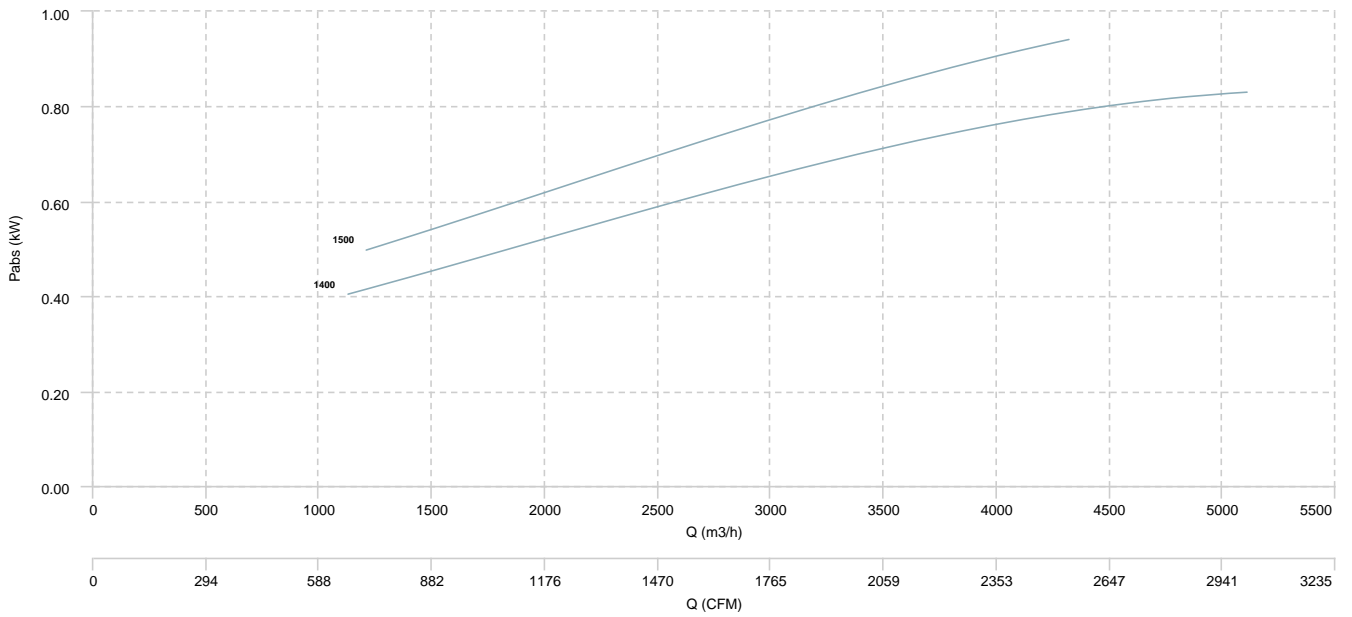

BOX BSTB 400 1,1kW

AIR FLOW - PRESSURE

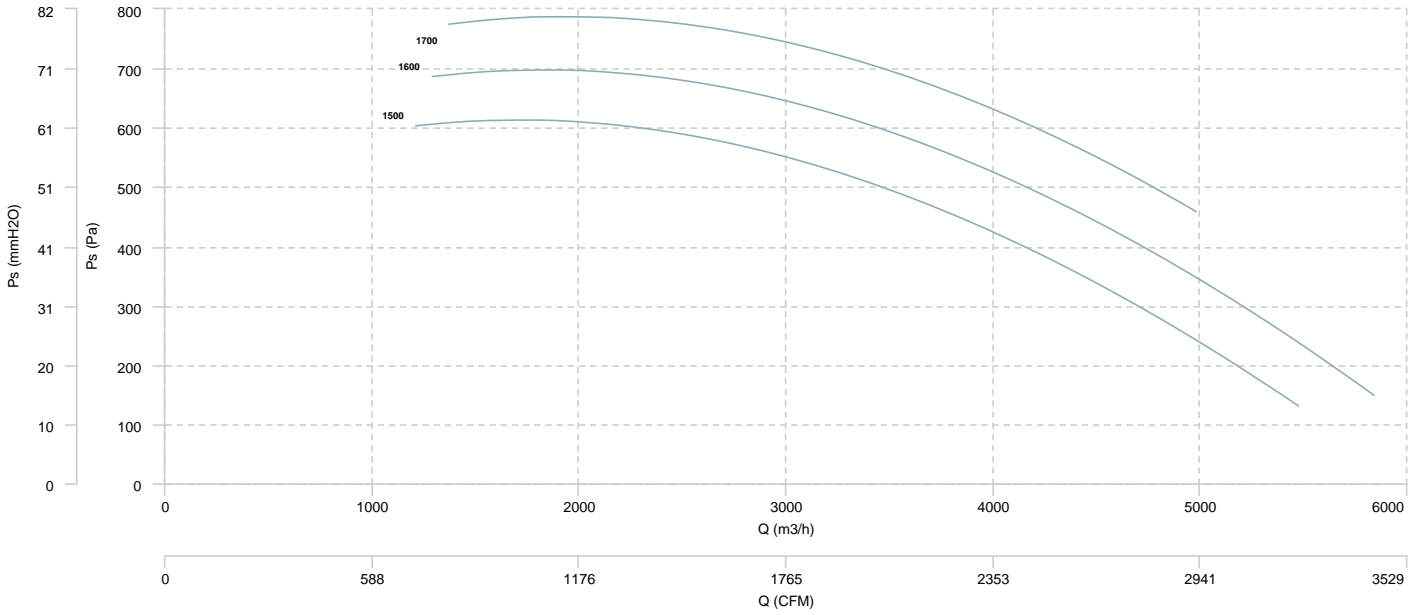

AIR FLOW - ABSORBED POWER

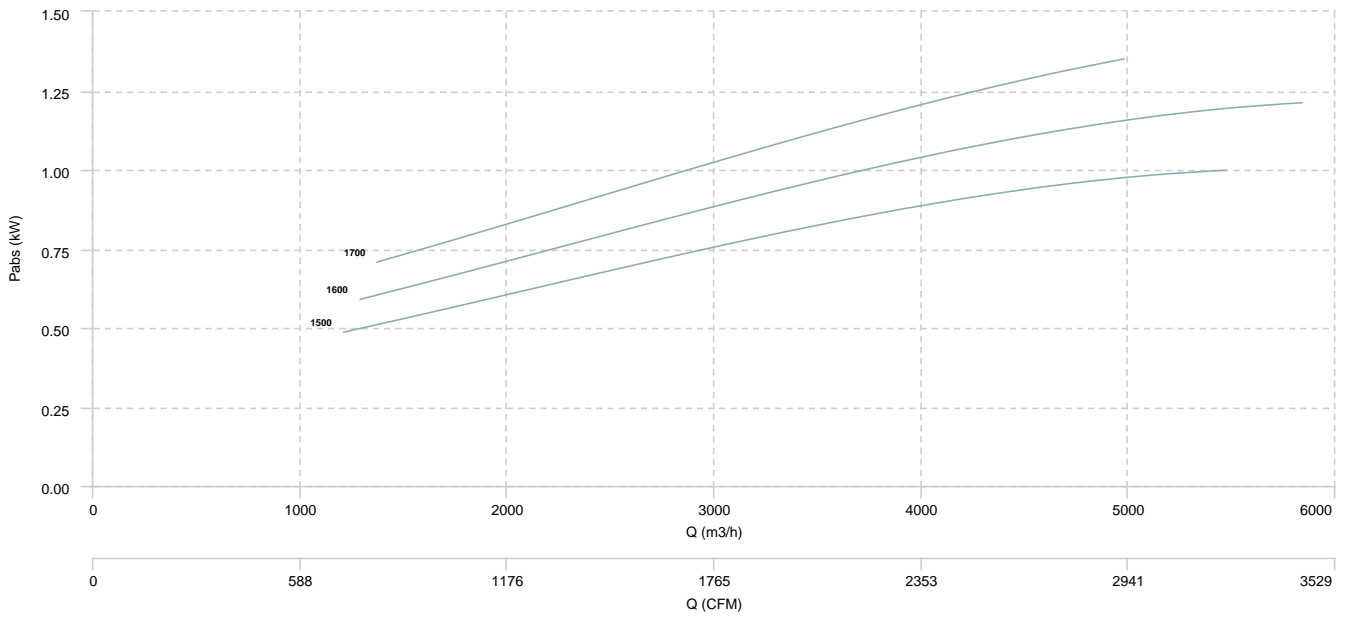

BOX BSTB 400 1,5kW

AIR FLOW - PRESSURE

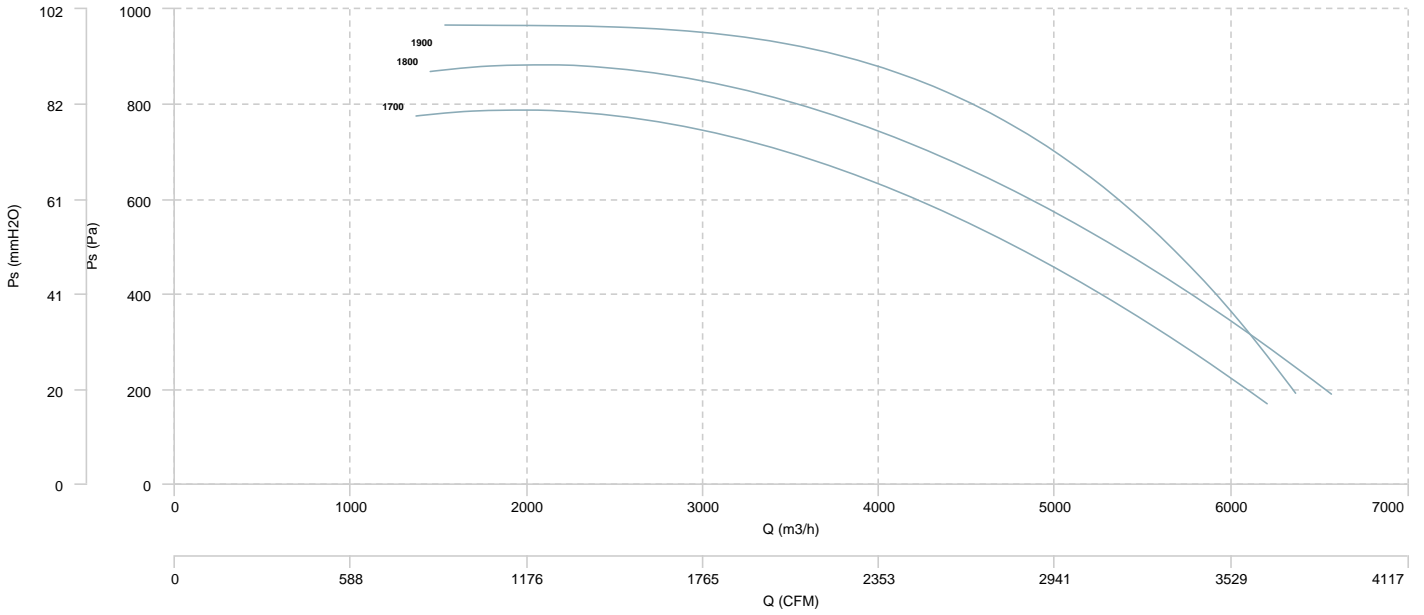

AIR FLOW - ABSORBED POWER

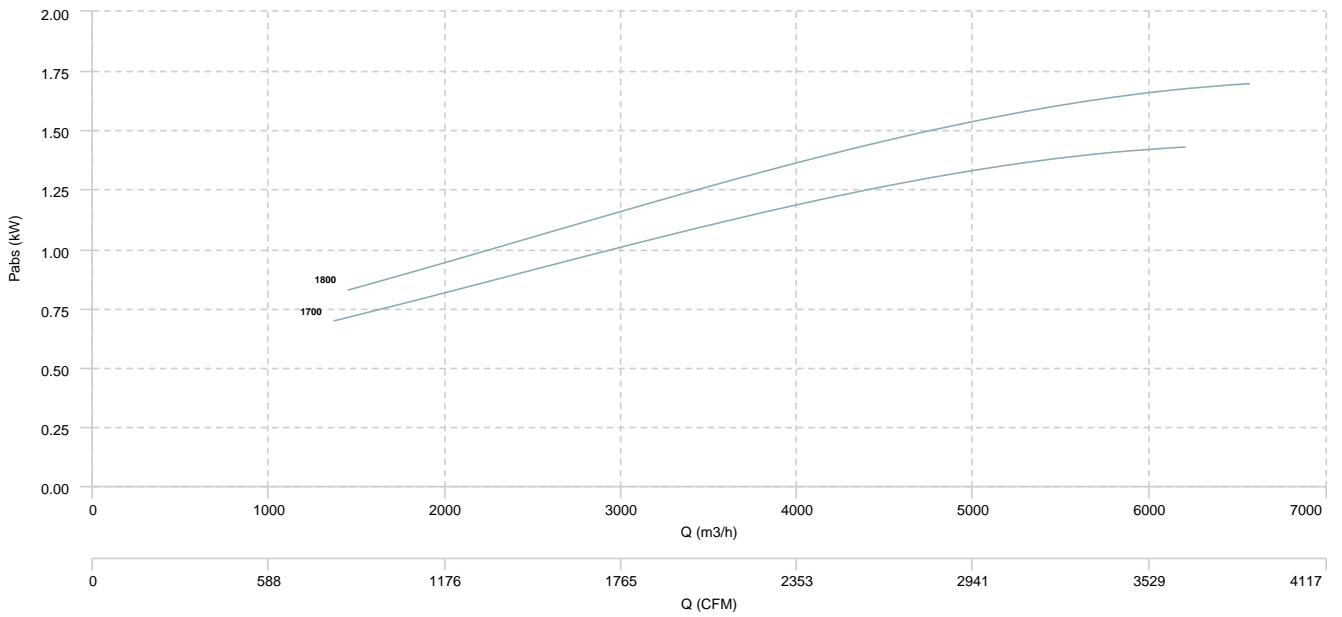

BOX BSTB 400 2,2kW

AIR FLOW - PRESSURE

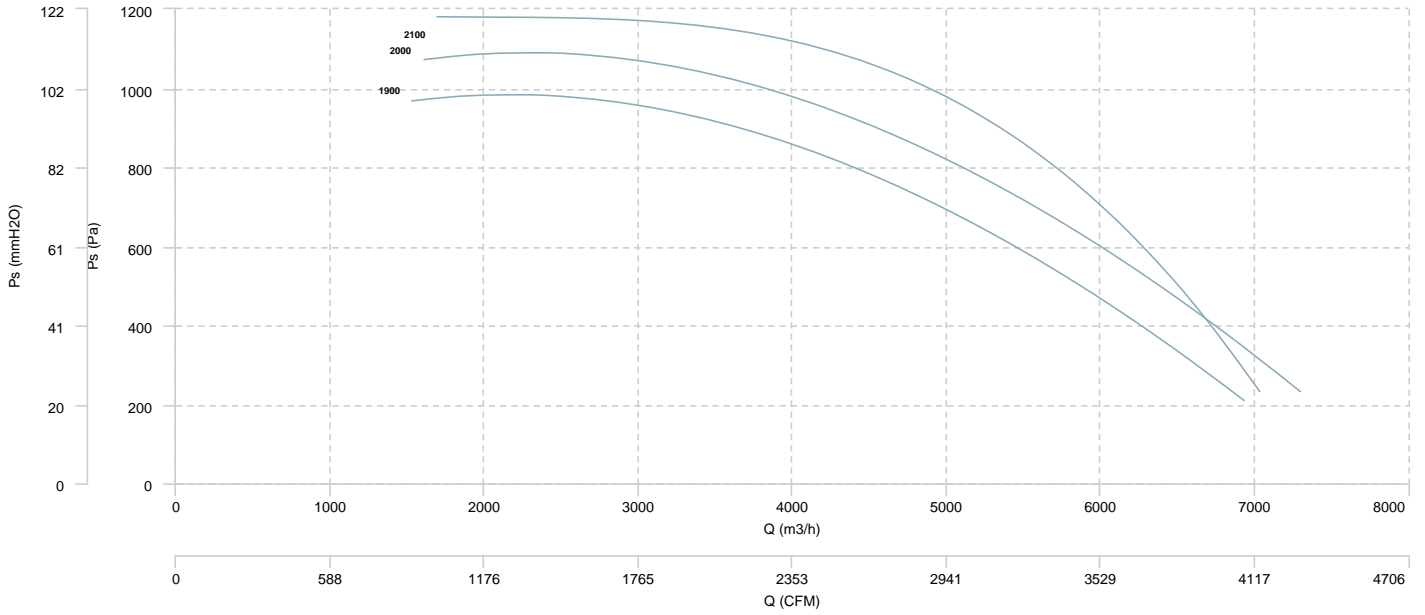

AIR FLOW - ABSORBED POWER

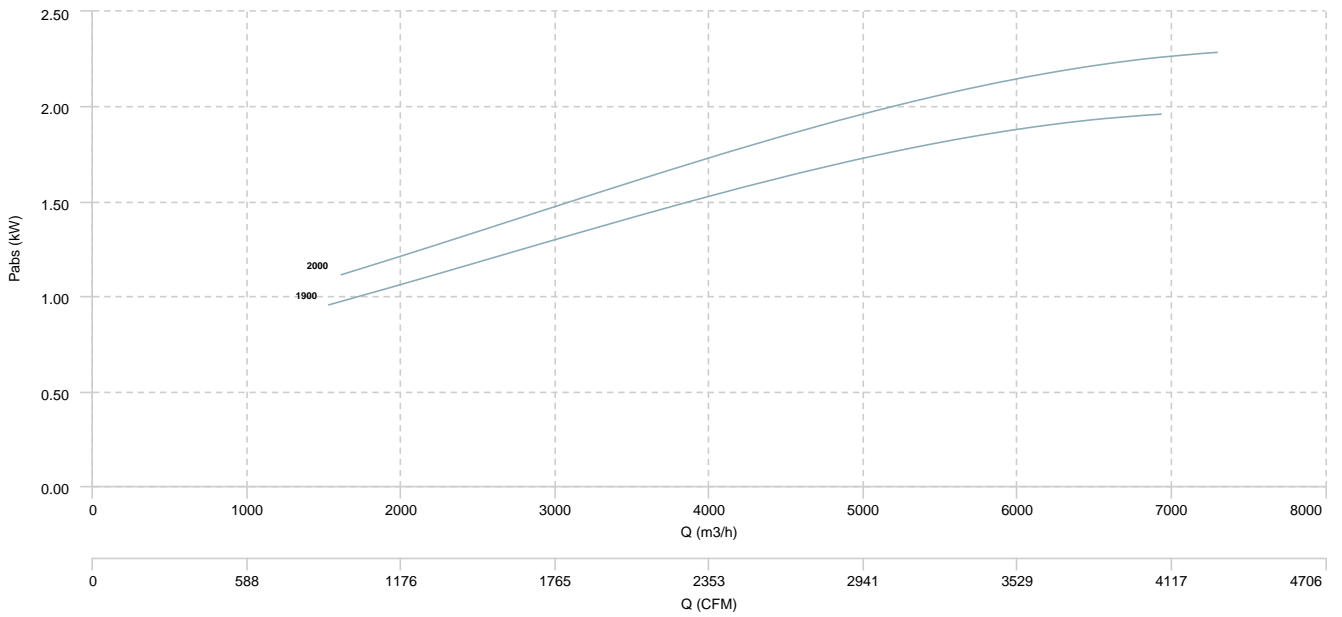

BOX BSTB 400 3kW

AIR FLOW - PRESSURE

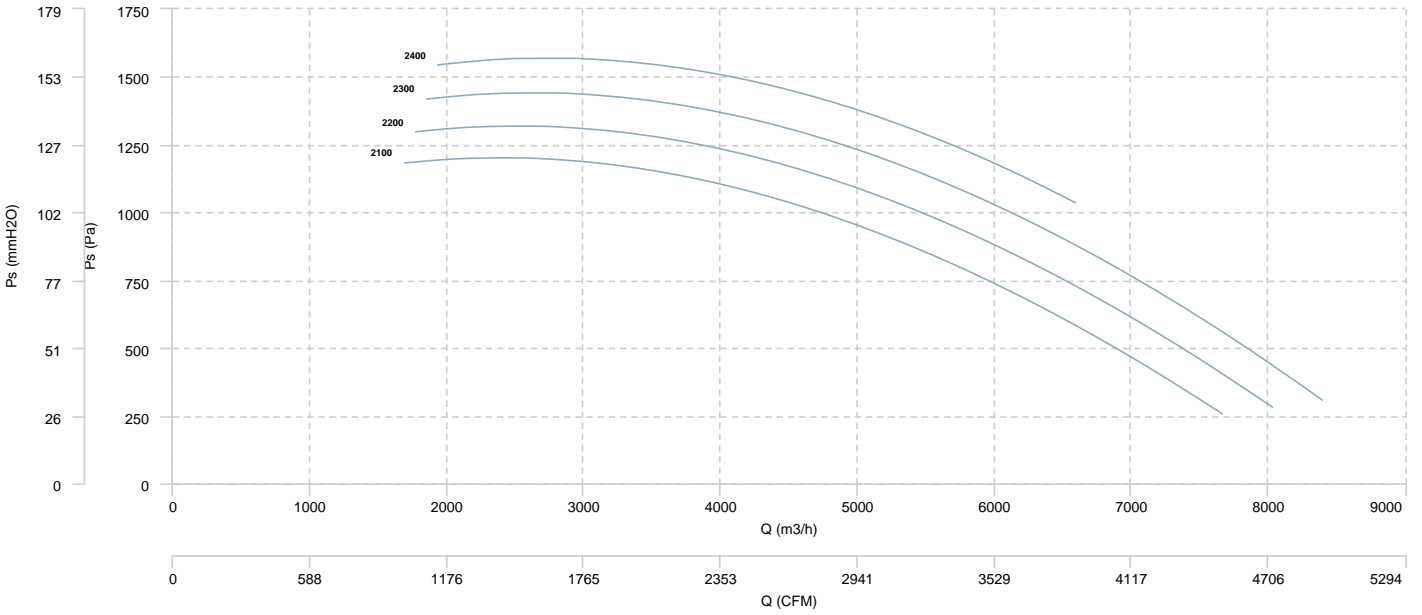

AIR FLOW - ABSORBED POWER

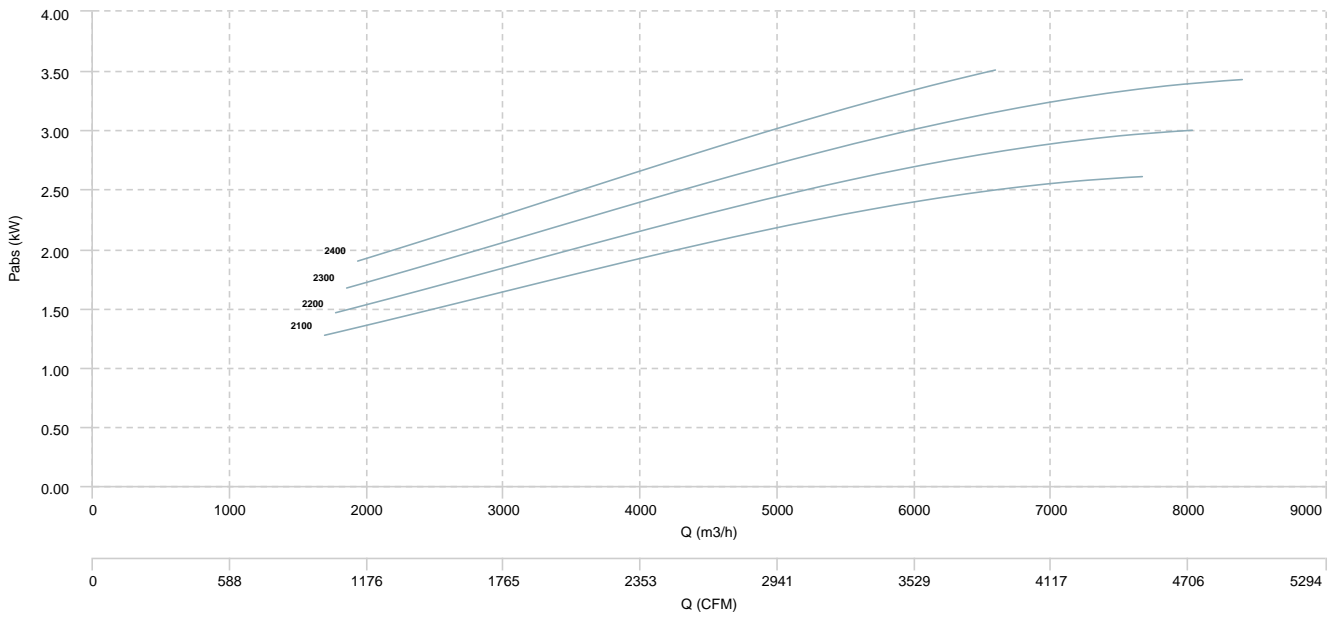

BOX BSTB 400 4kW

AIR FLOW - PRESSURE

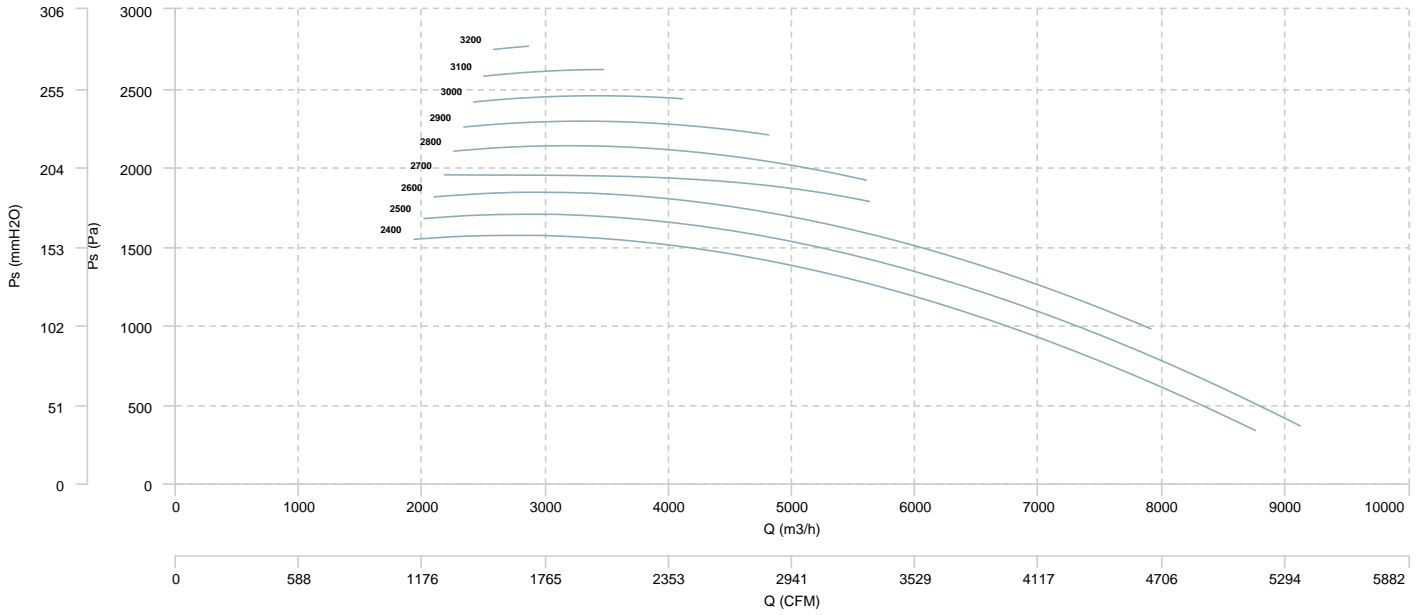

AIR FLOW - ABSORBED POWER

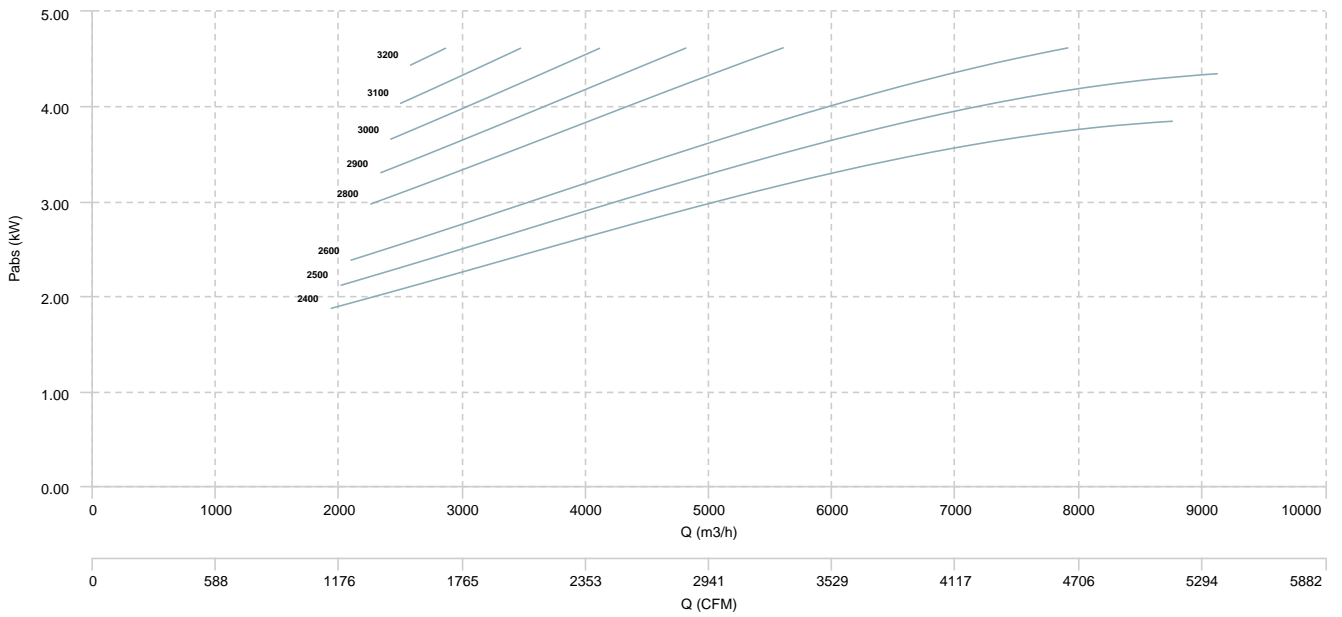

BOX BSTB 450 0,75kW

AIR FLOW - PRESSURE

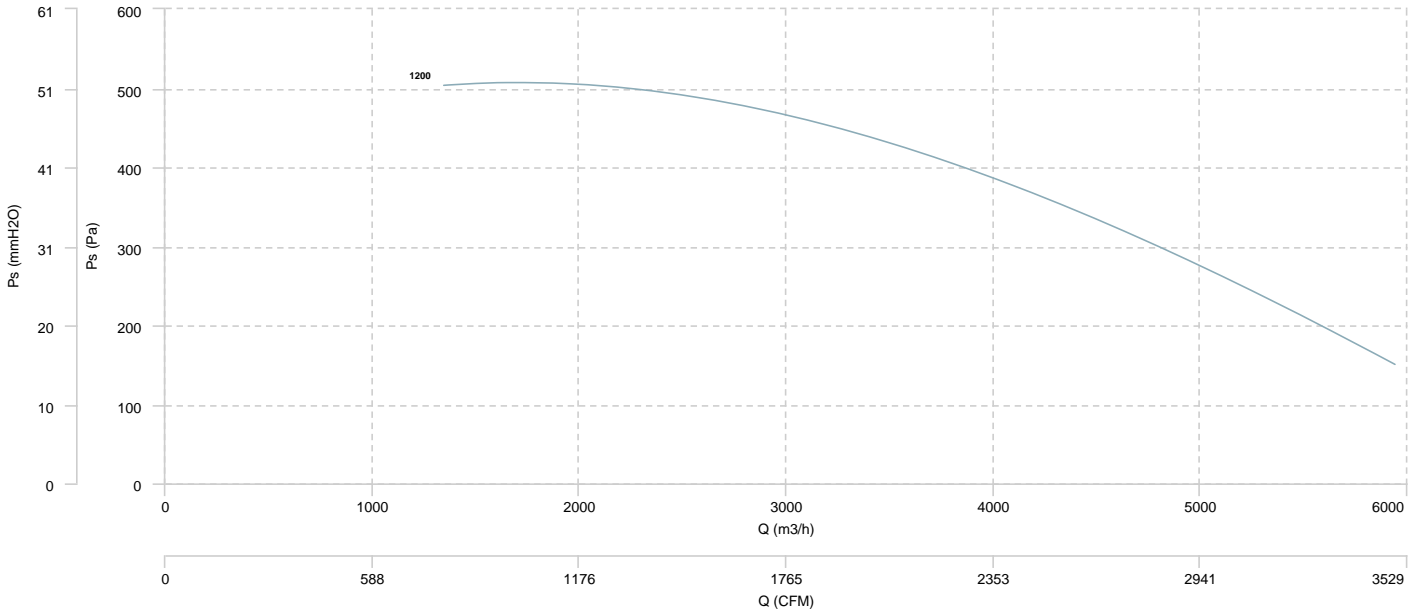

AIR FLOW - ABSORBED POWER

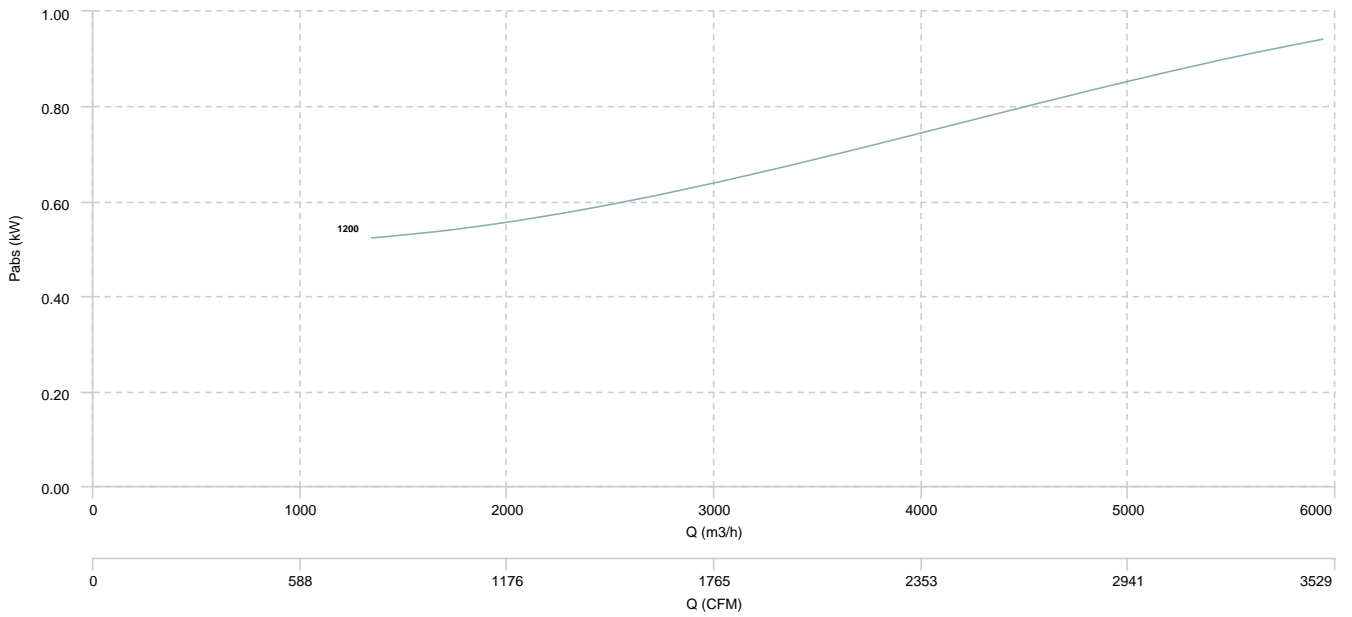

BOX BSTB 450 1,1kW

AIR FLOW - PRESSURE

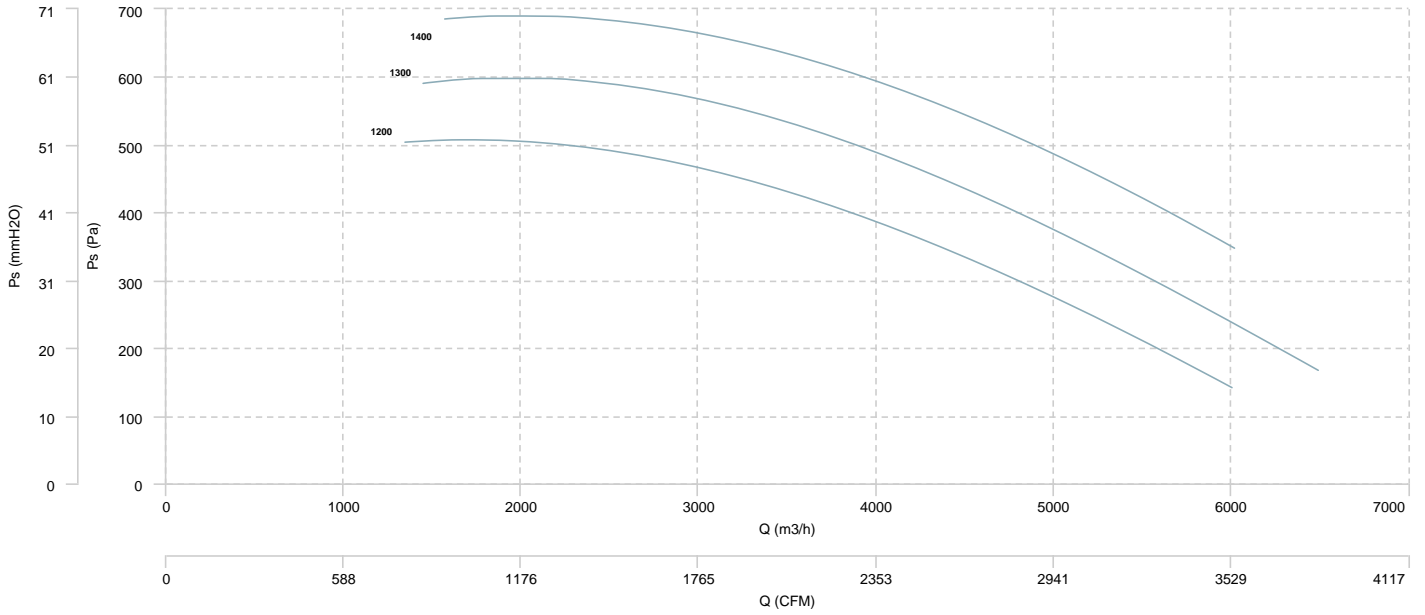

AIR FLOW - ABSORBED POWER

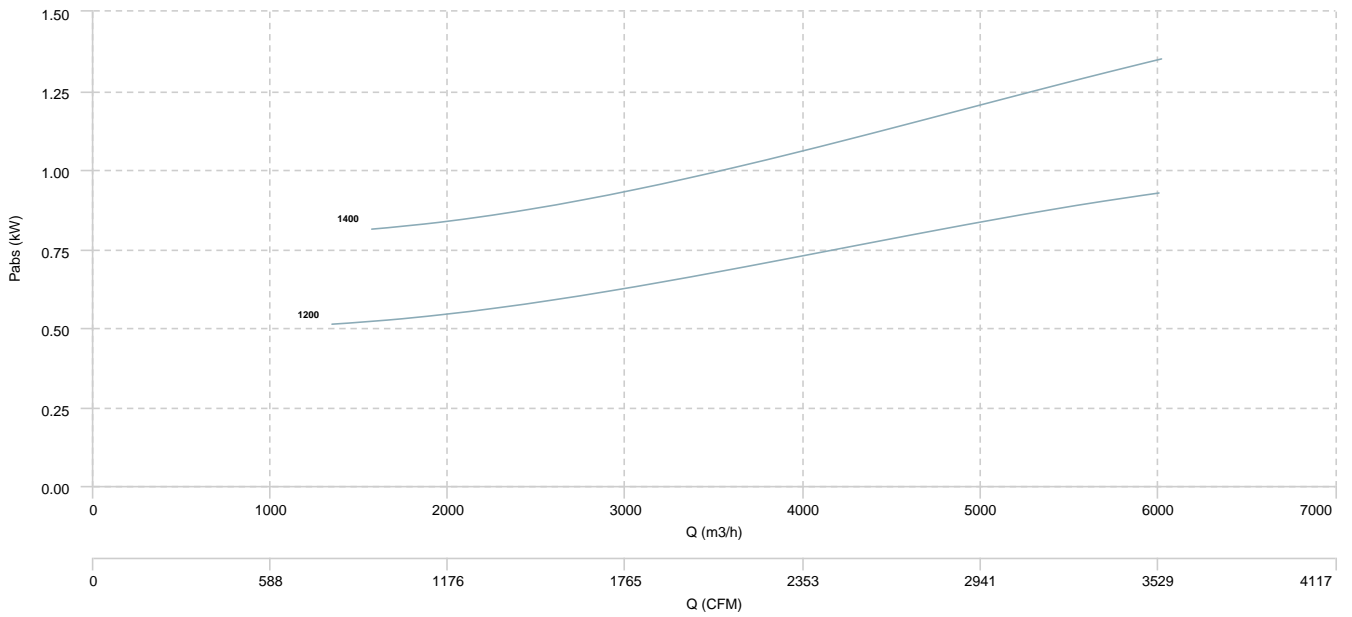

BOX BSTB 450 1,5kW

AIR FLOW - PRESSURE

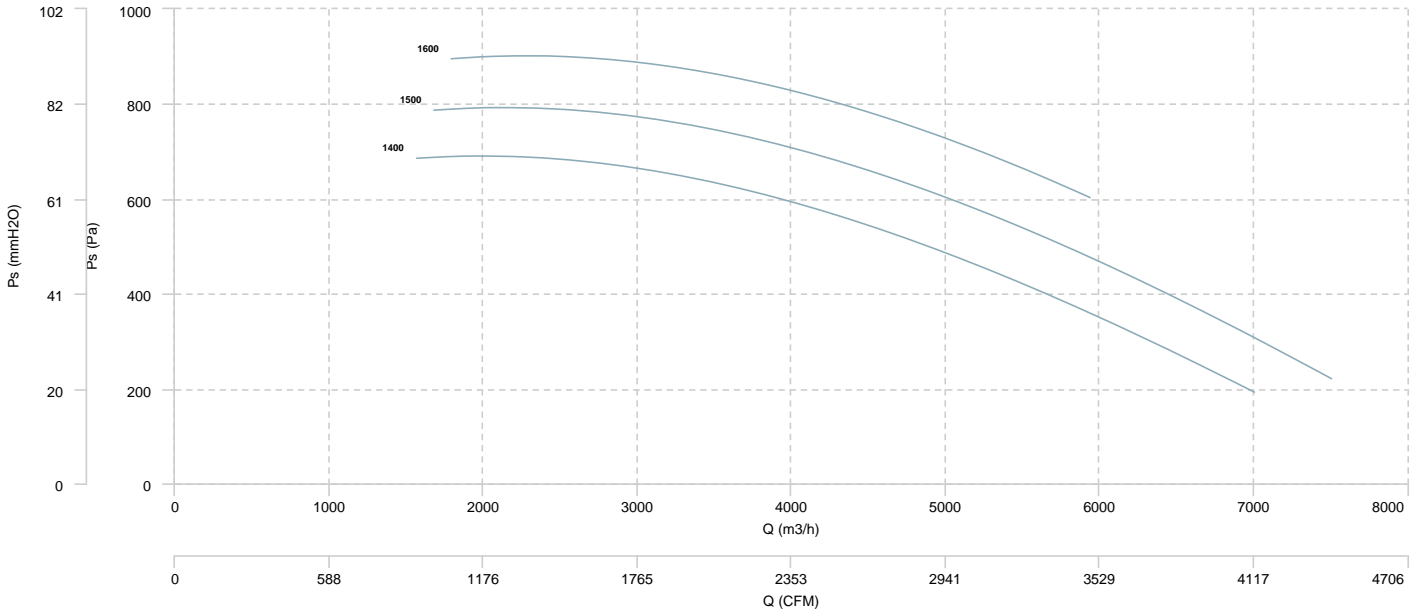

AIR FLOW - ABSORBED POWER

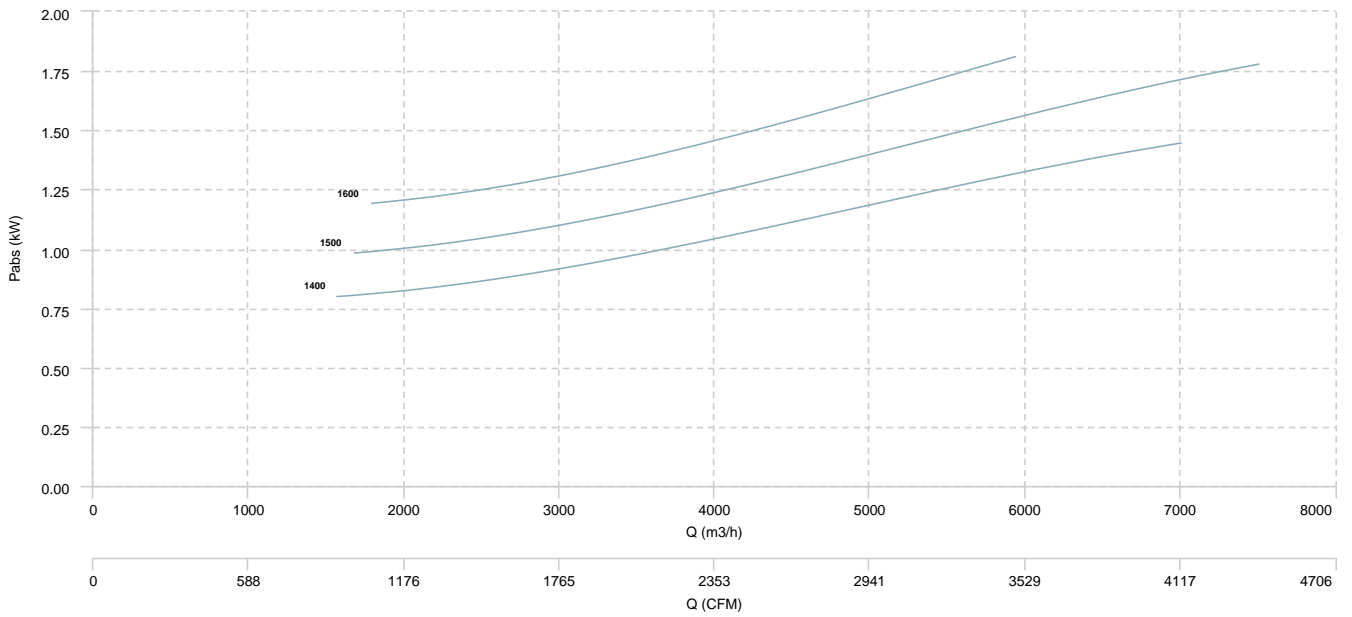

BOX BSTB 450 2,2kW

AIR FLOW - PRESSURE

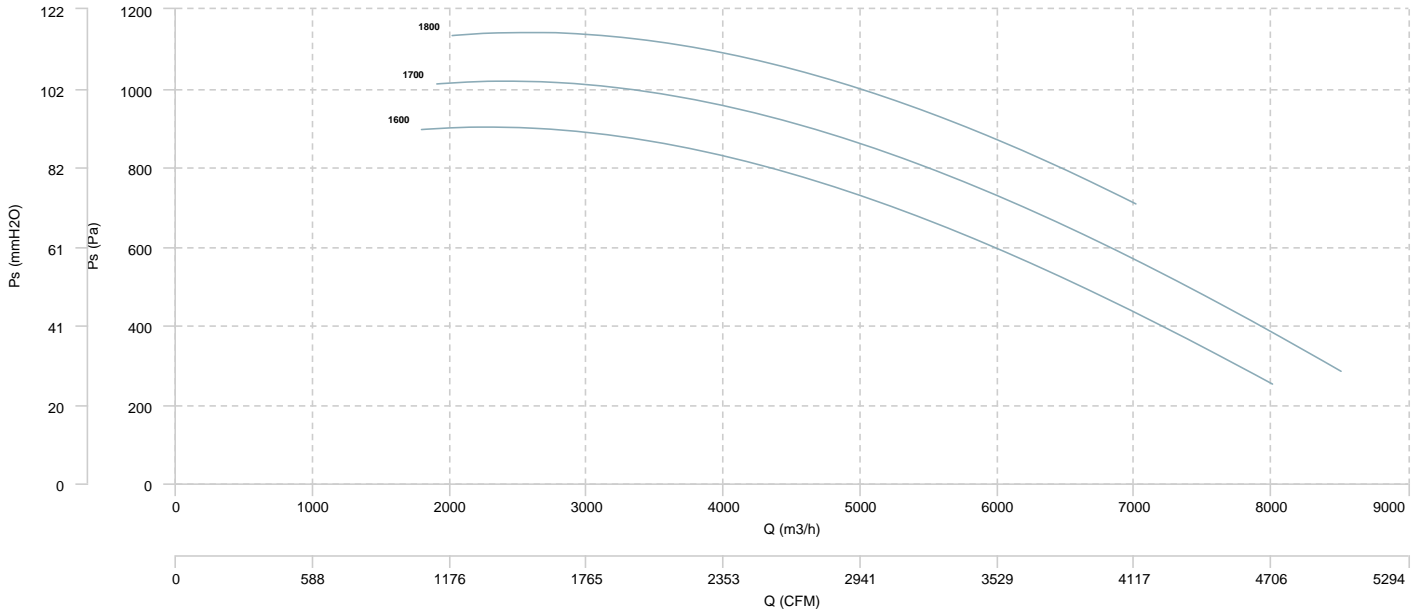

AIR FLOW - ABSORBED POWER

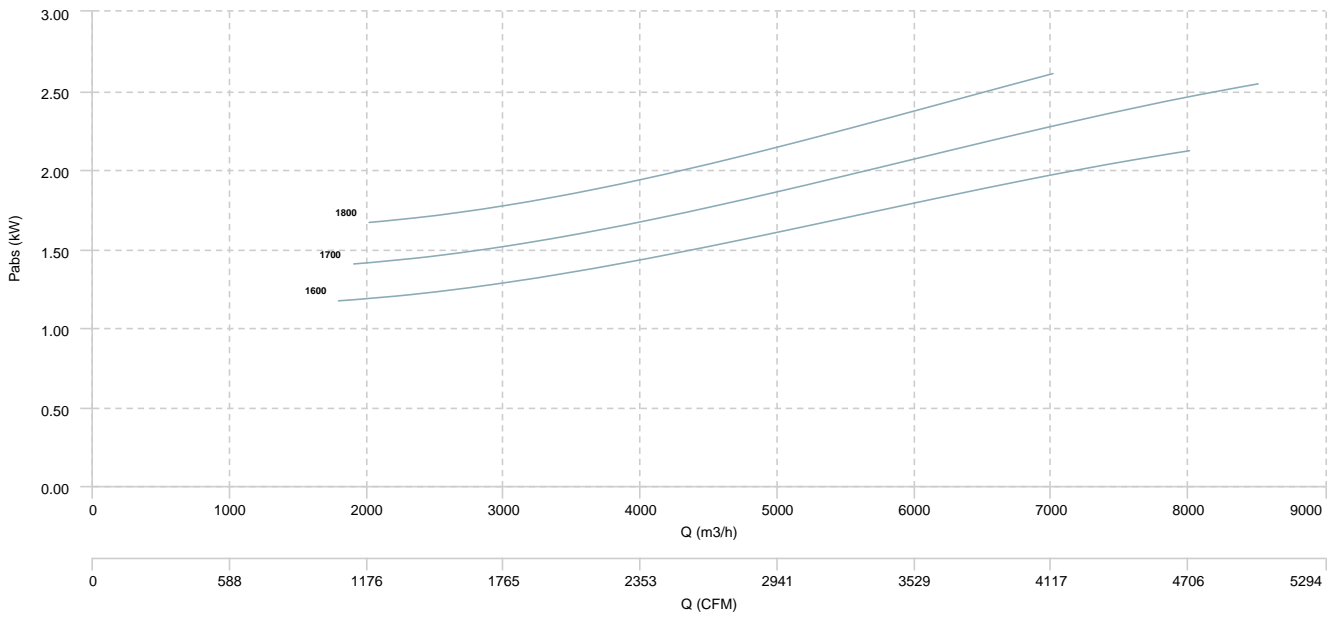

BOX BSTB 450 3kW

AIR FLOW - PRESSURE

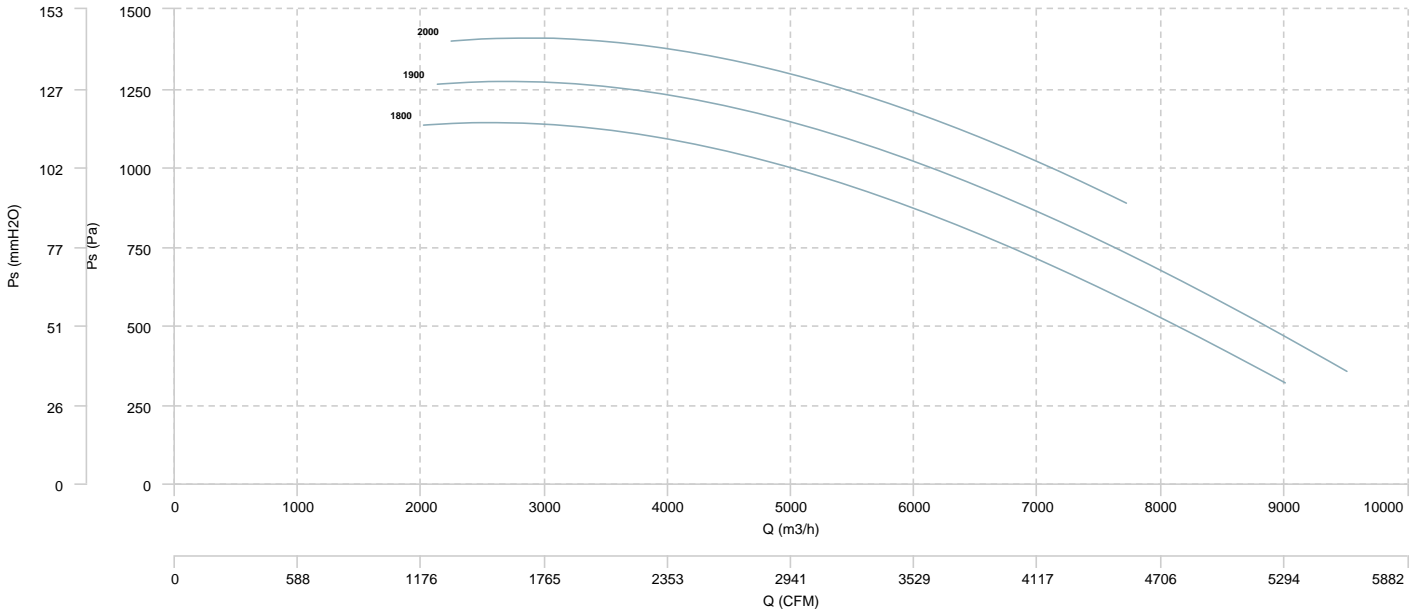

AIR FLOW - ABSORBED POWER

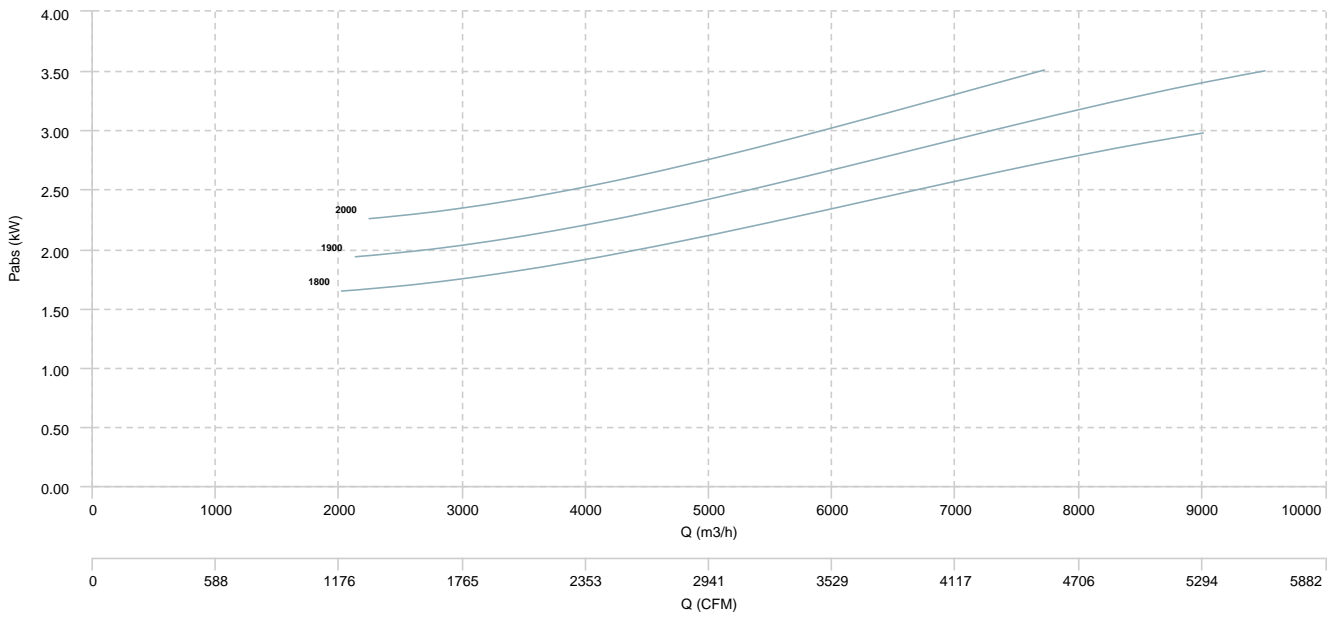

BOX BSTB 450 4kW

AIR FLOW - PRESSURE

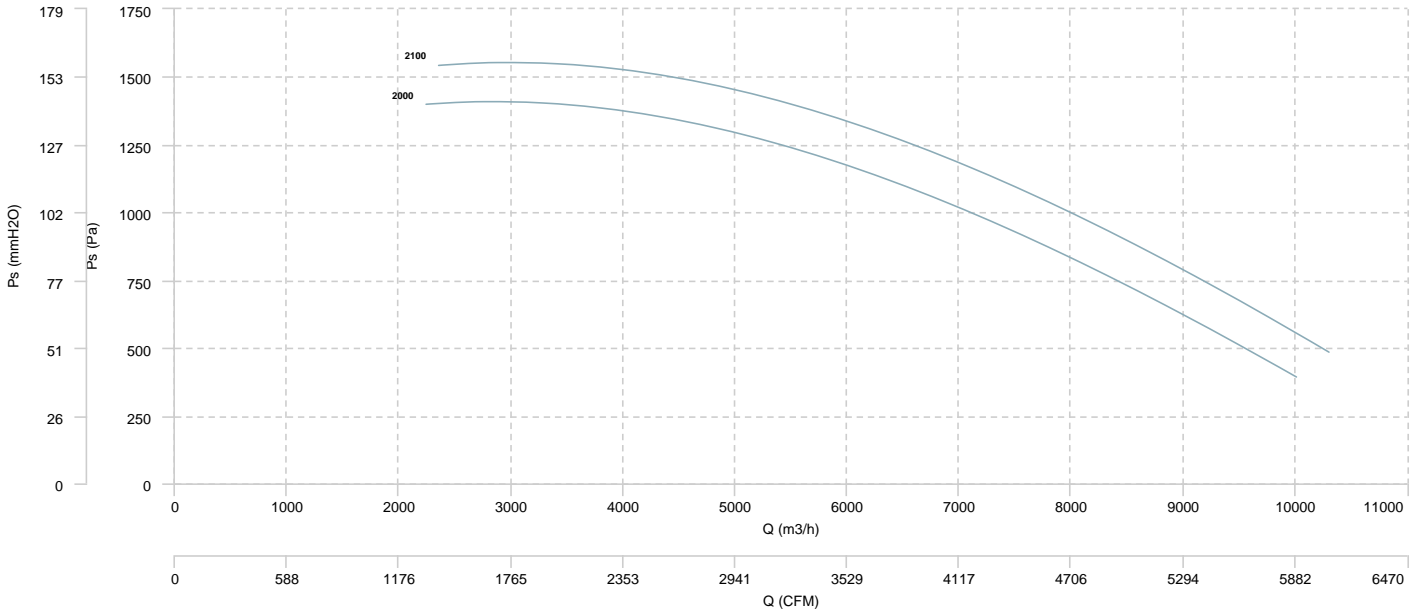

AIR FLOW - ABSORBED POWER

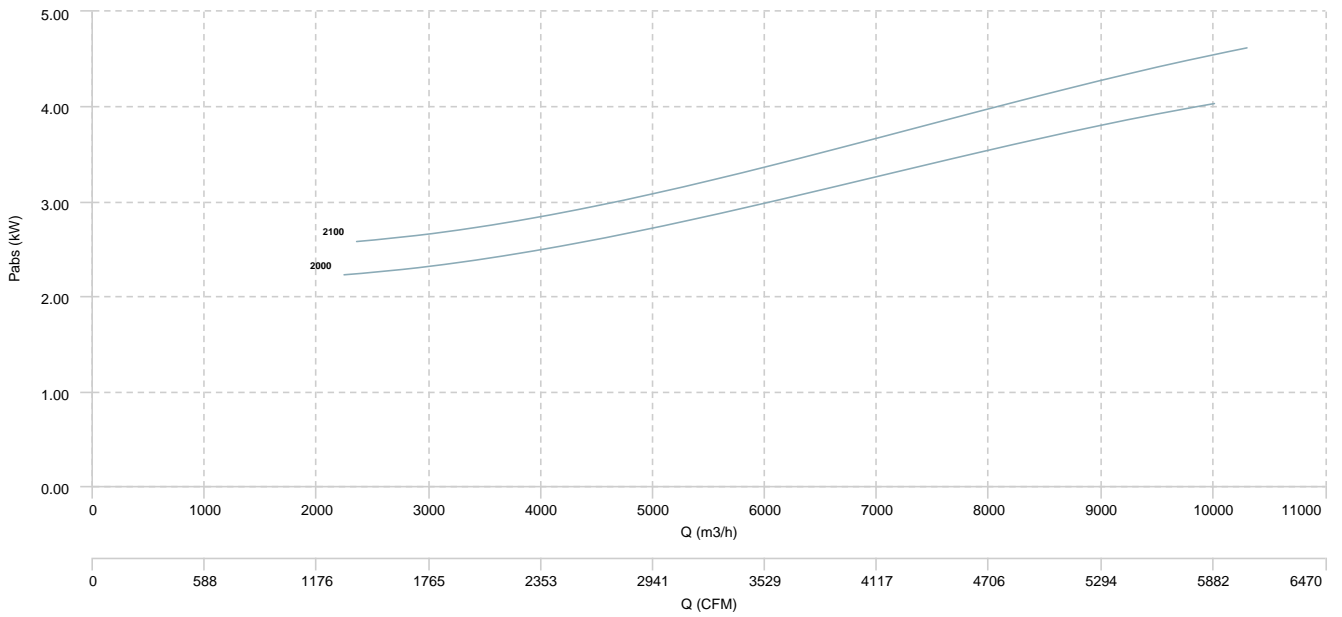

BOX BSTB 450 5,5kW

AIR FLOW - PRESSURE

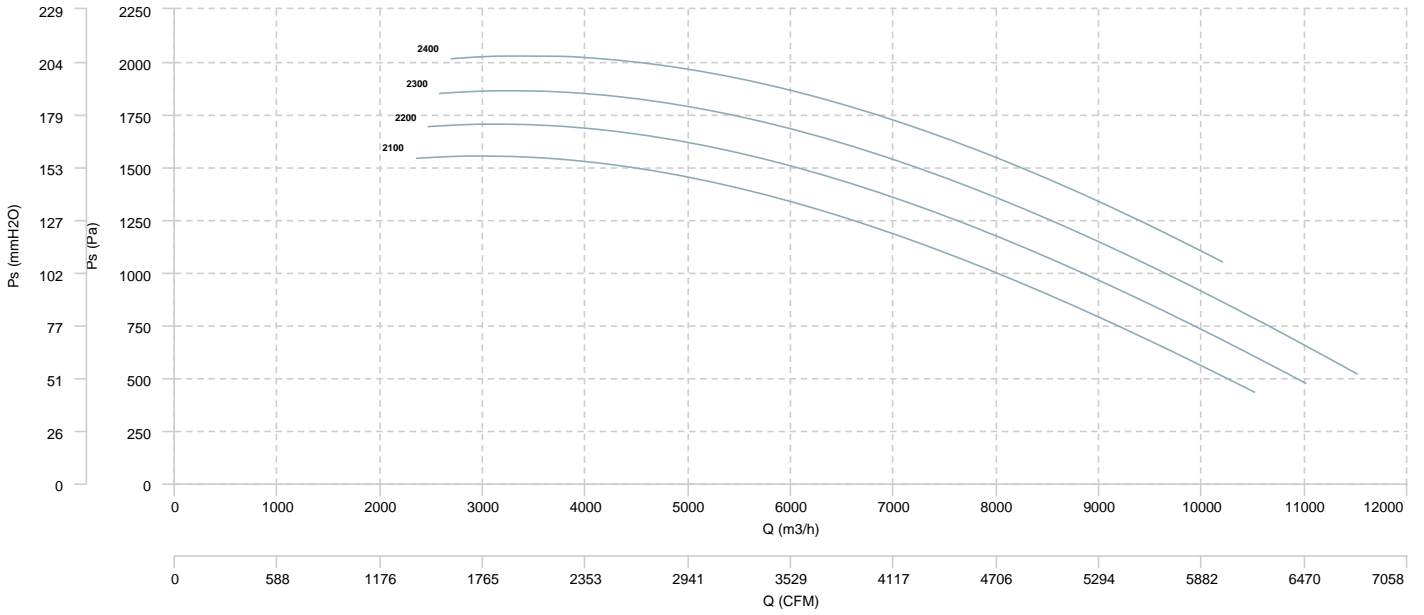

AIR FLOW - ABSORBED POWER

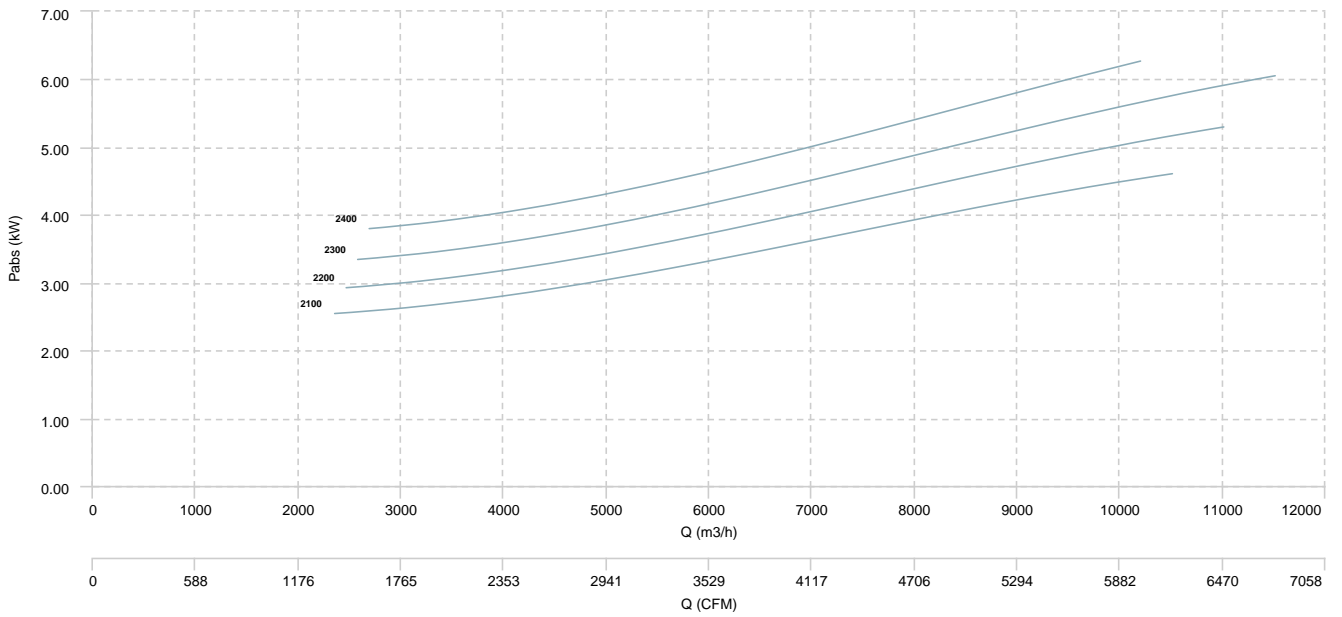

BOX BSTB 450 7,5kW

AIR FLOW - PRESSURE

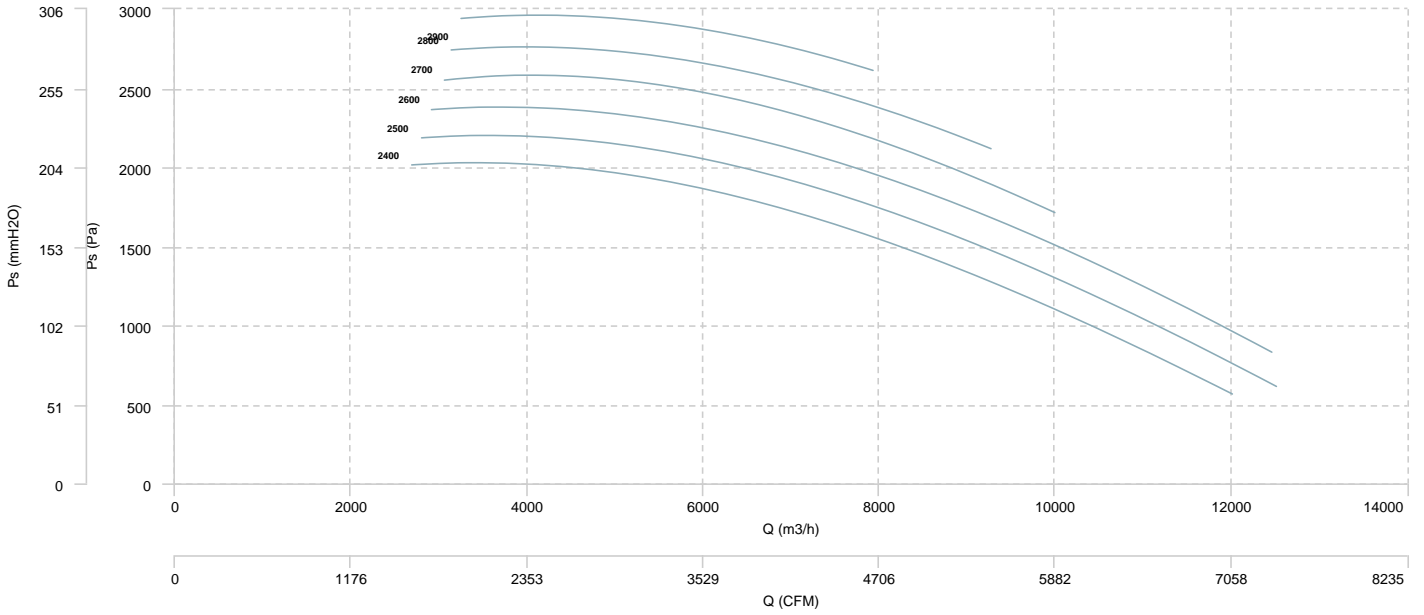

AIR FLOW - ABSORBED POWER

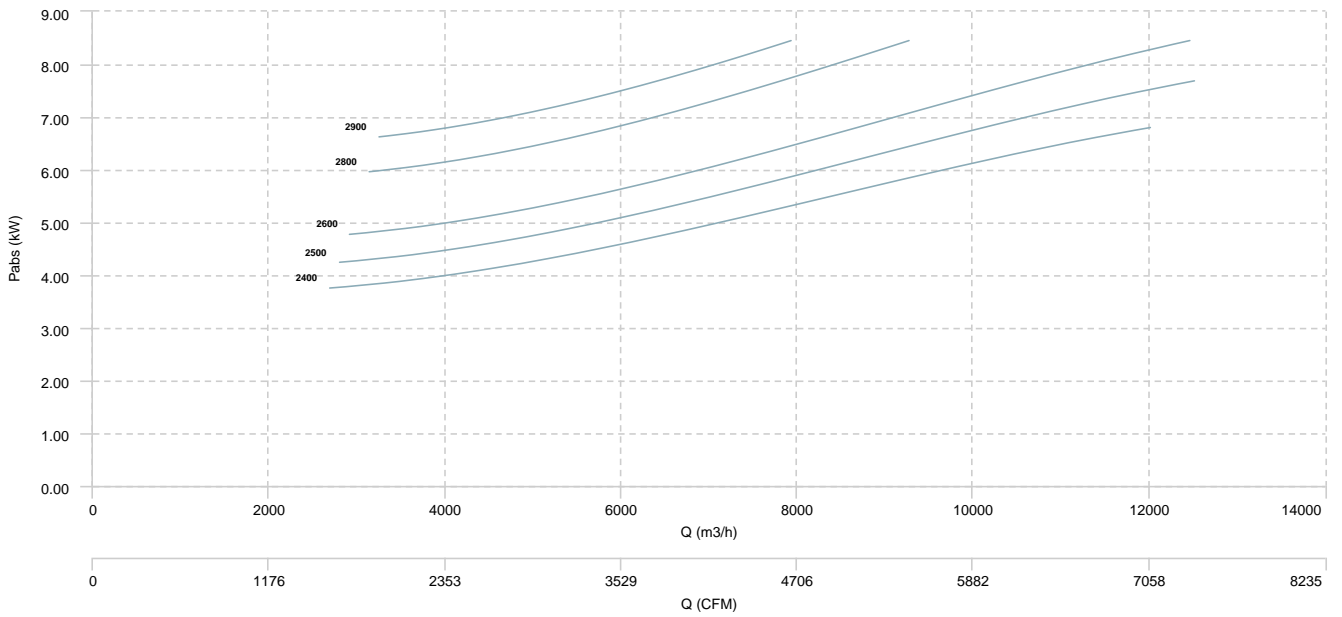

BOX BSTB 500 1,1kW

AIR FLOW - PRESSURE

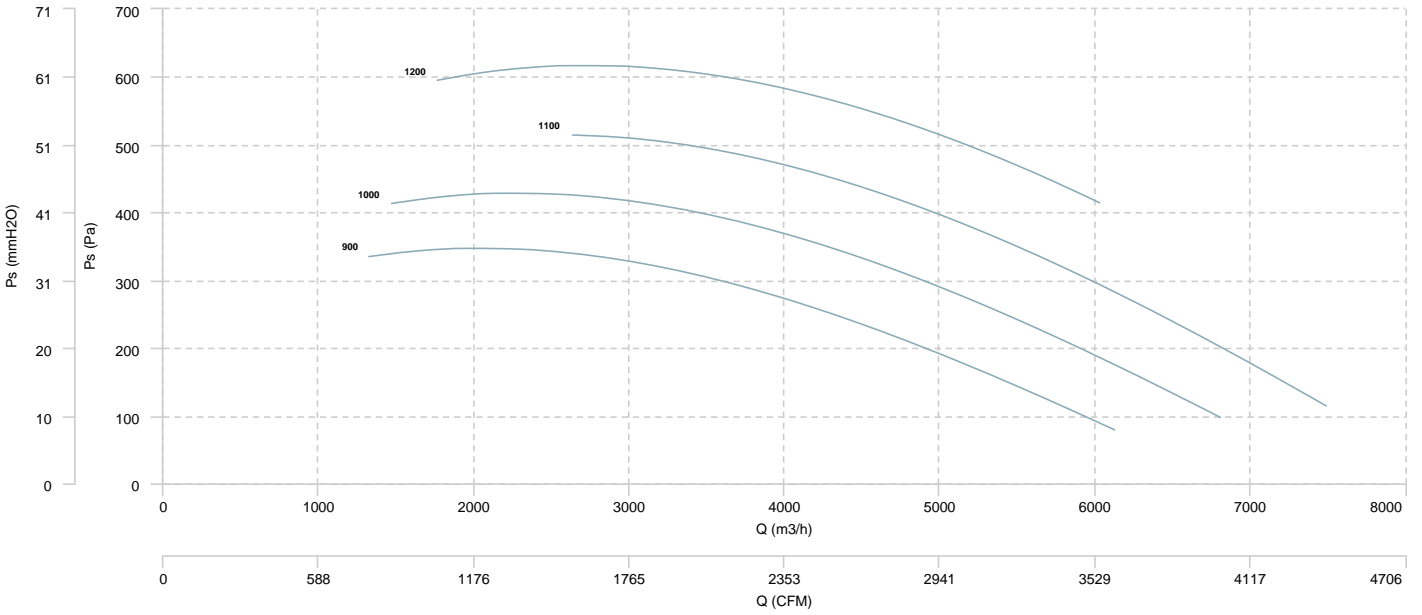

AIR FLOW - ABSORBED POWER

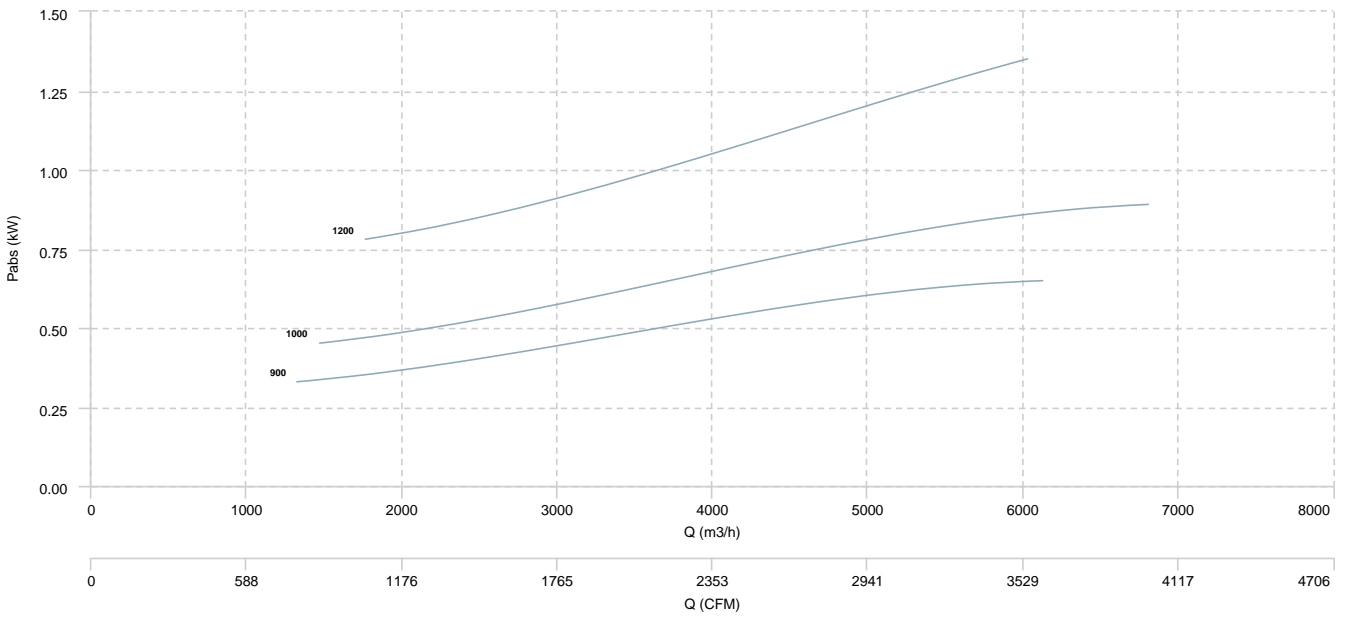

BOX BSTB 500 1,5kW

AIR FLOW - PRESSURE

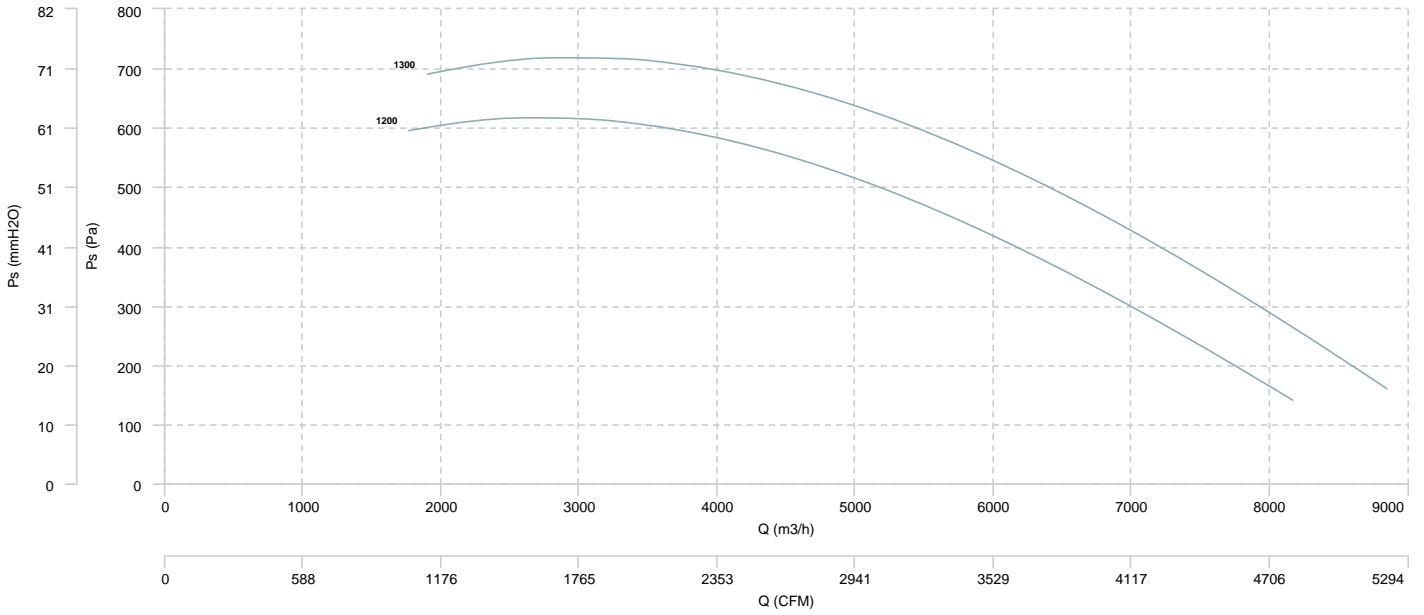

AIR FLOW - ABSORBED POWER

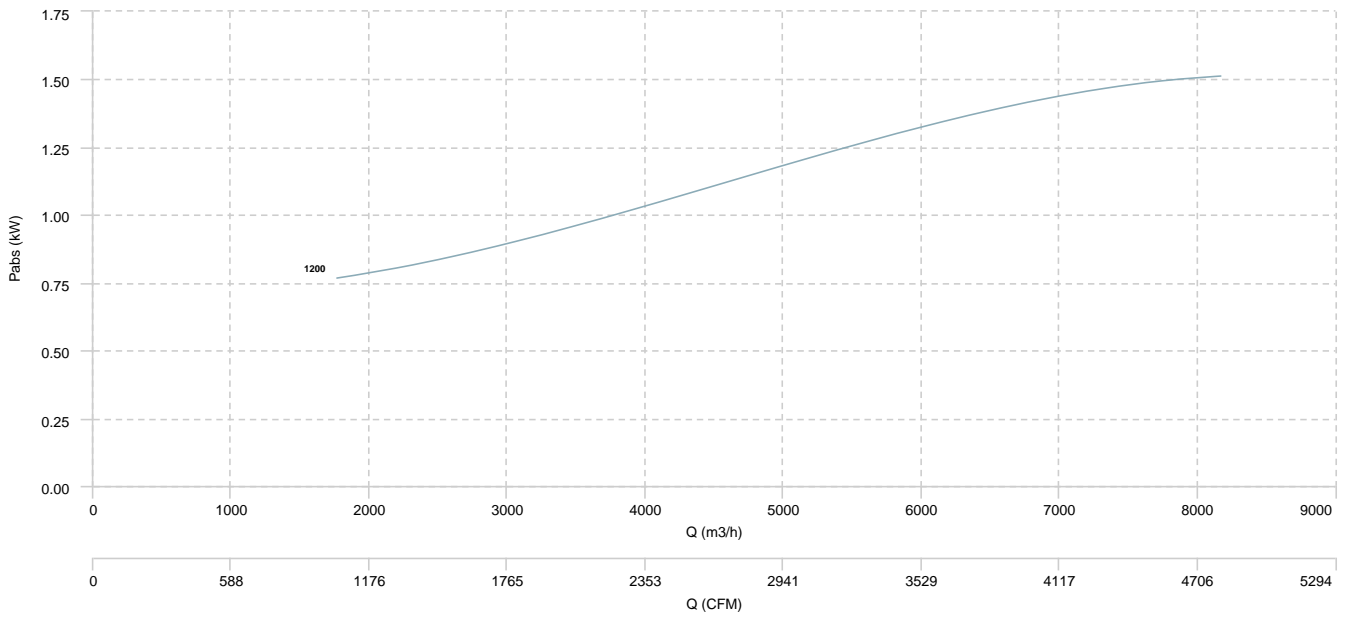

BOX BSTB 500 2,2kW

AIR FLOW - PRESSURE

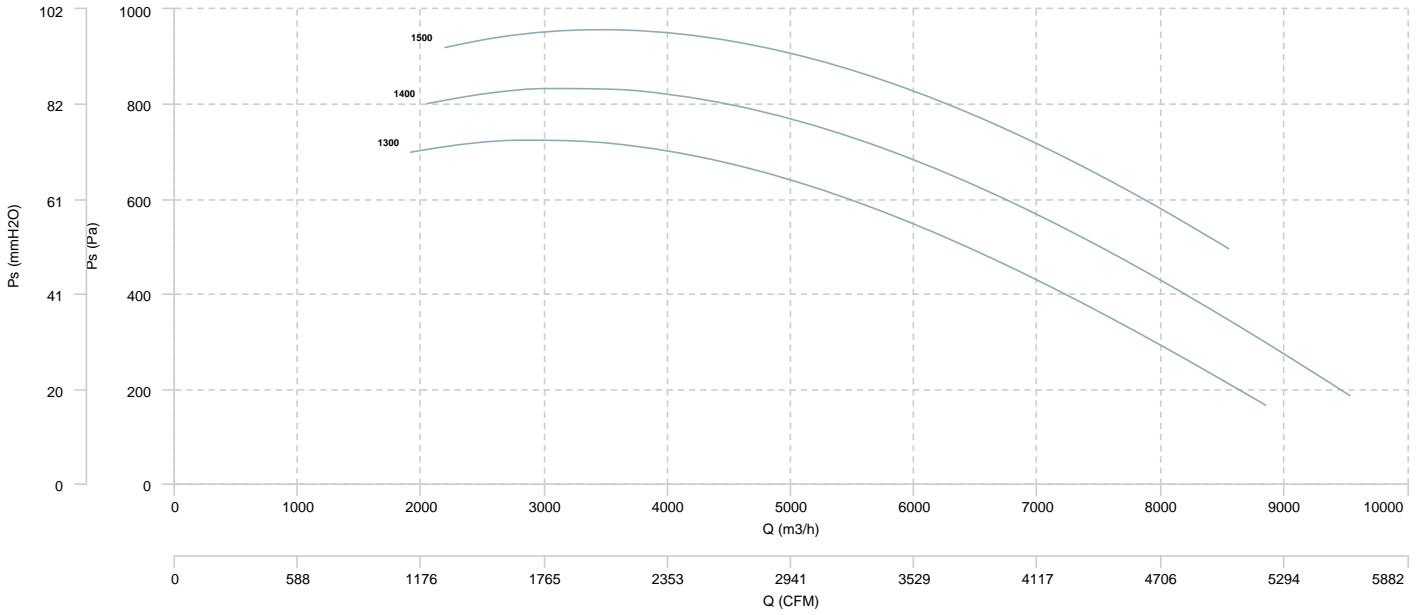

AIR FLOW - ABSORBED POWER

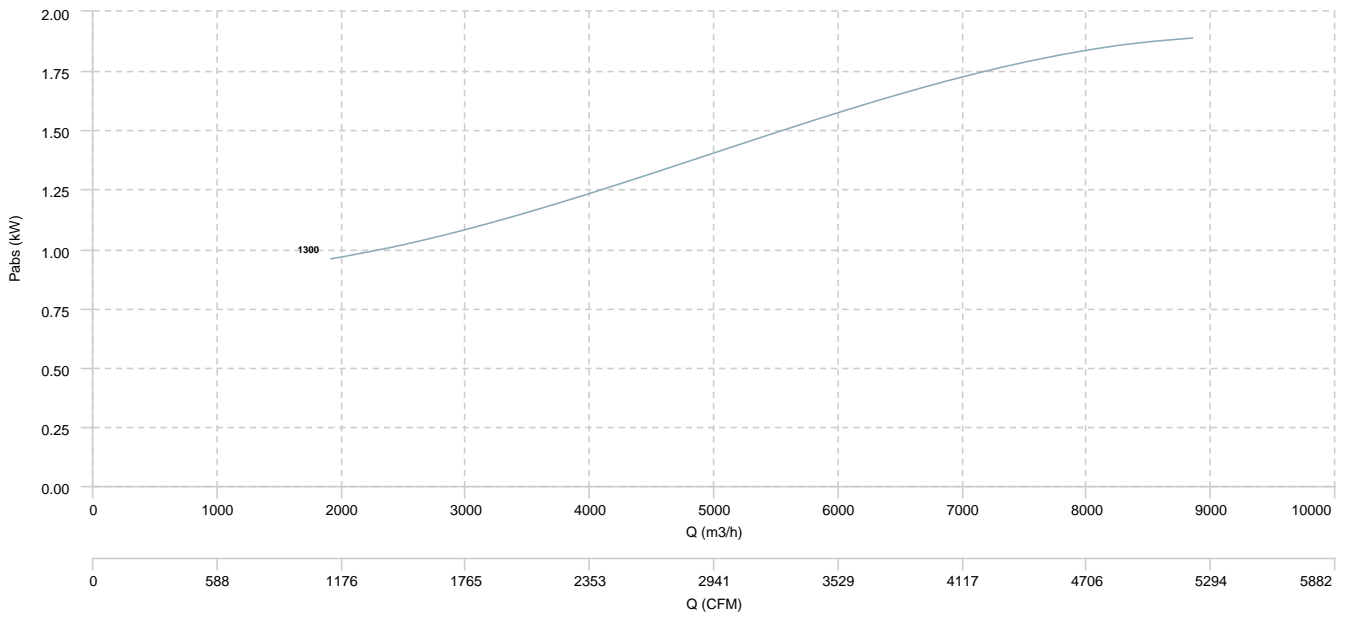

BOX BSTB 500 3kW

AIR FLOW - PRESSURE

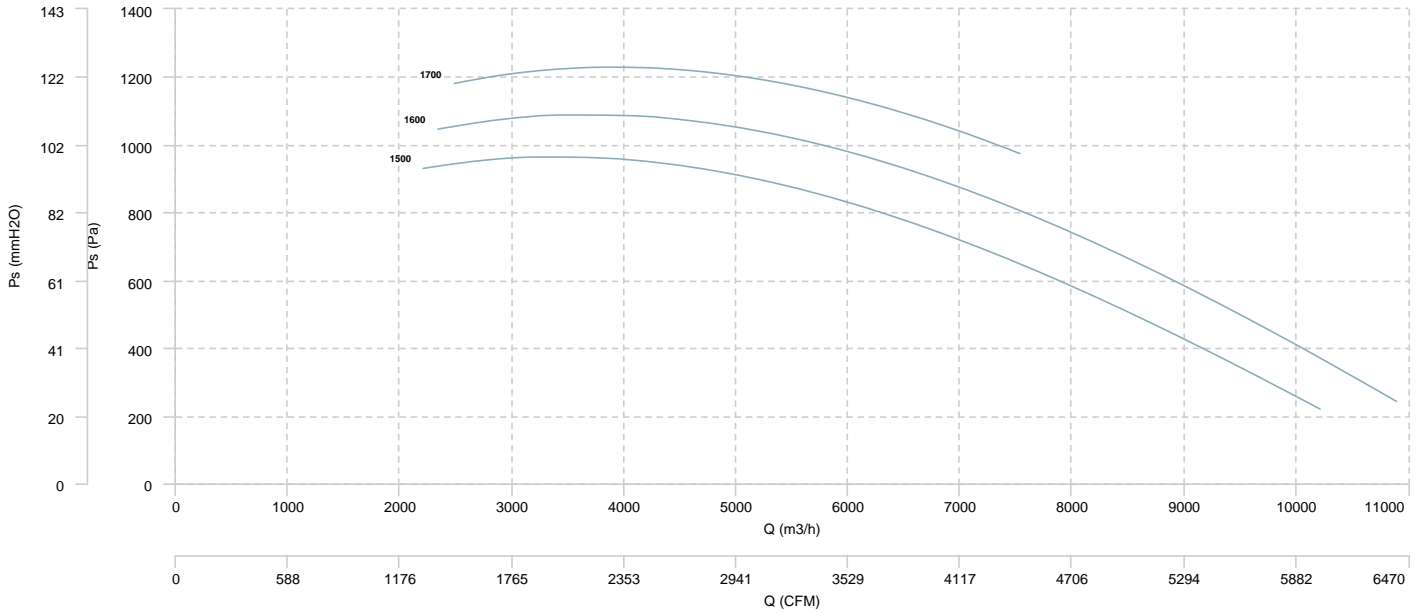

AIR FLOW - ABSORBED POWER

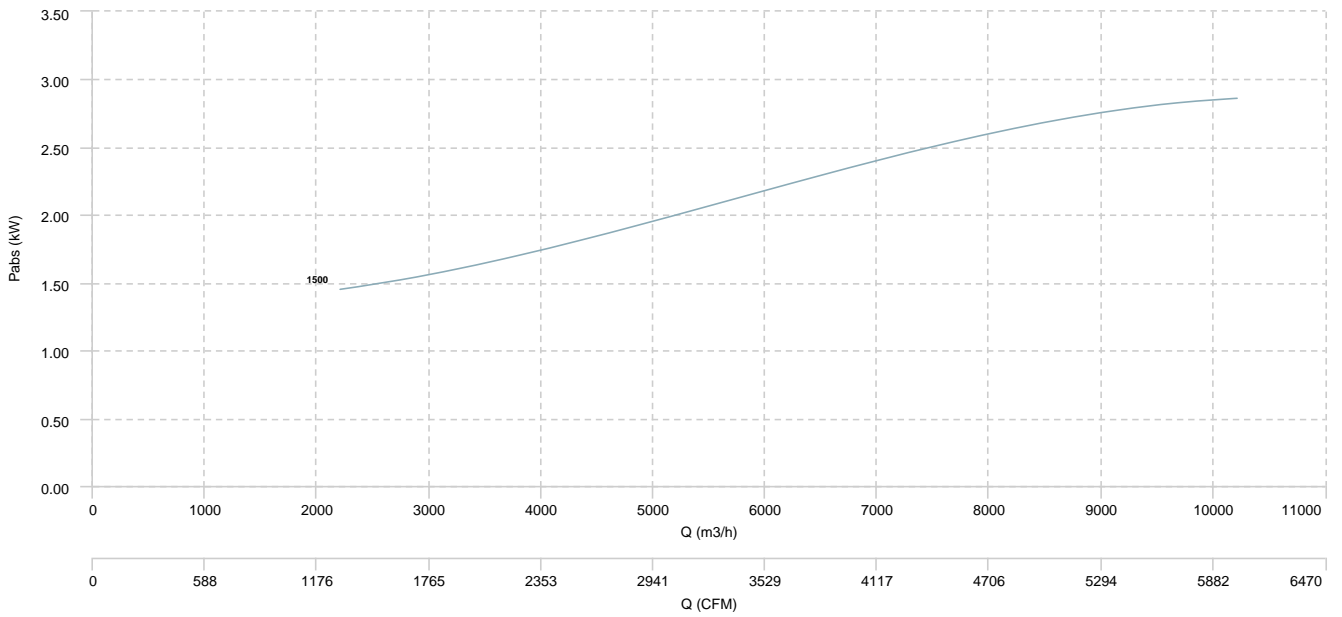

BOX BSTB 500 4kW

AIR FLOW - PRESSURE

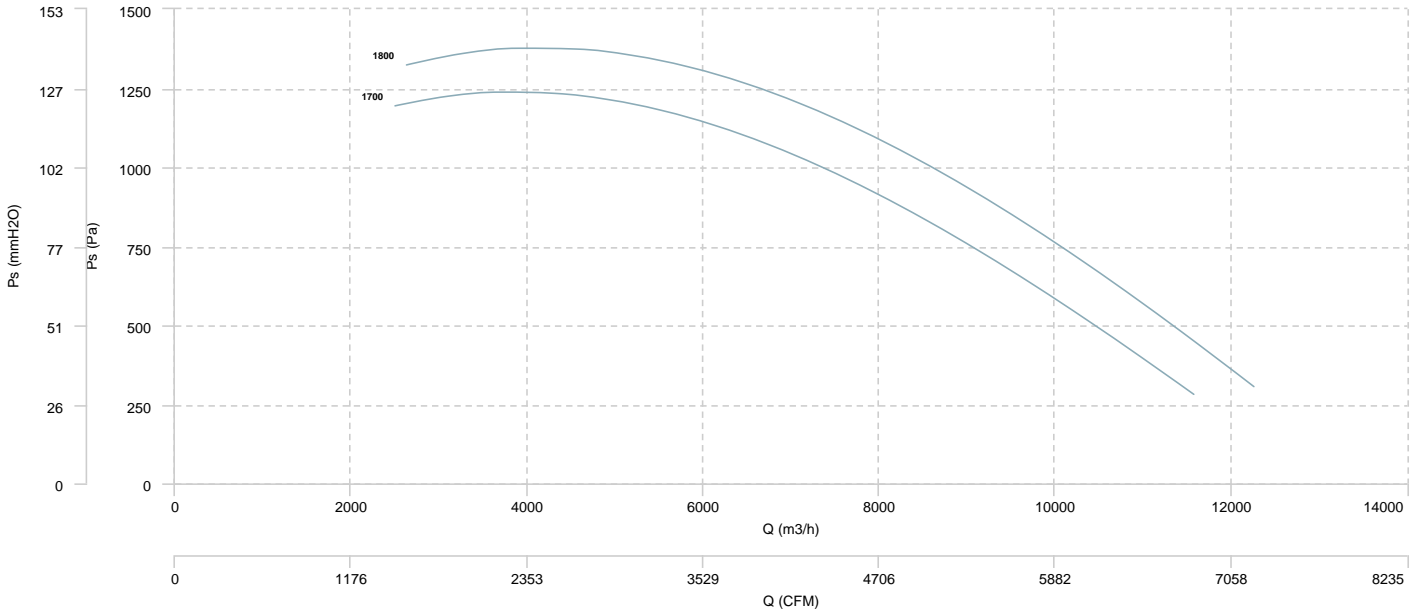

AIR FLOW - ABSORBED POWER

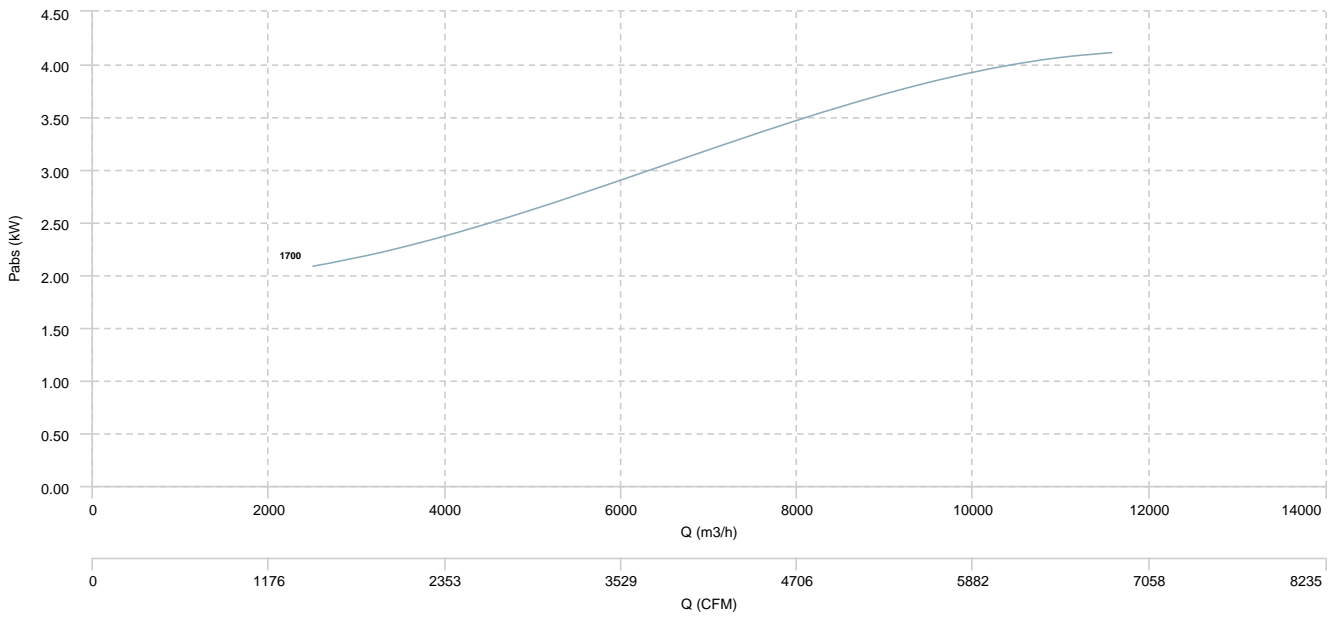

BOX BSTB 500 5,5kW

AIR FLOW - PRESSURE

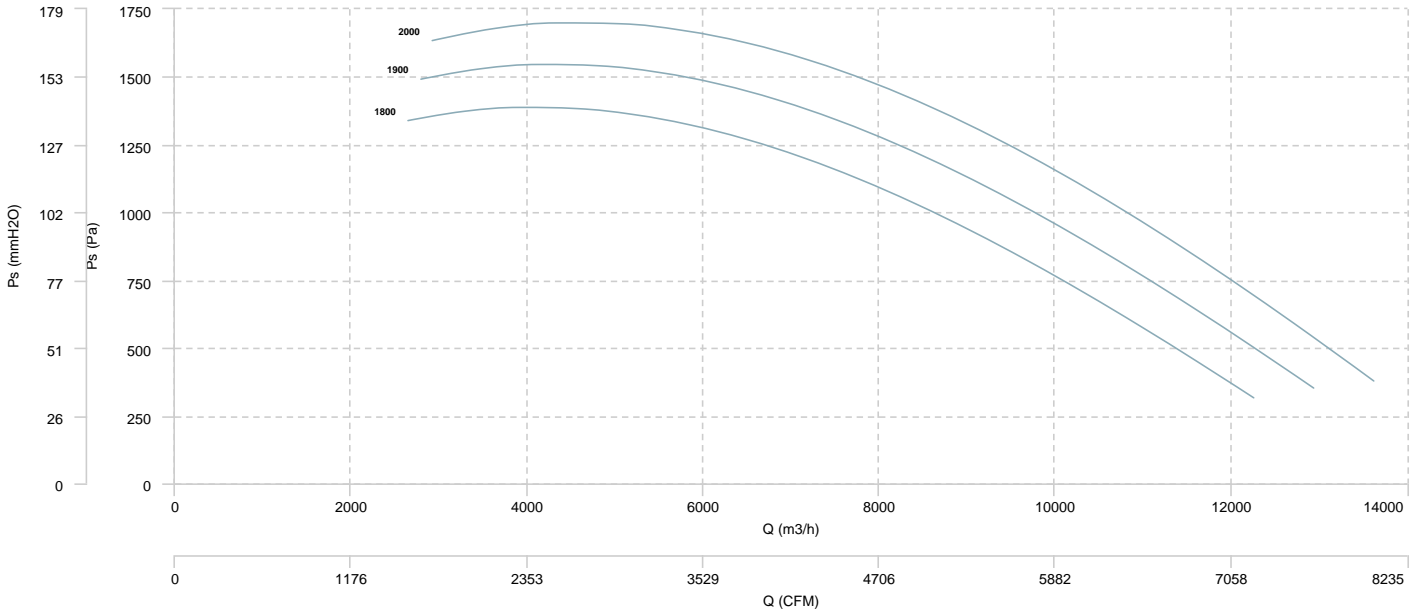

AIR FLOW - ABSORBED POWER

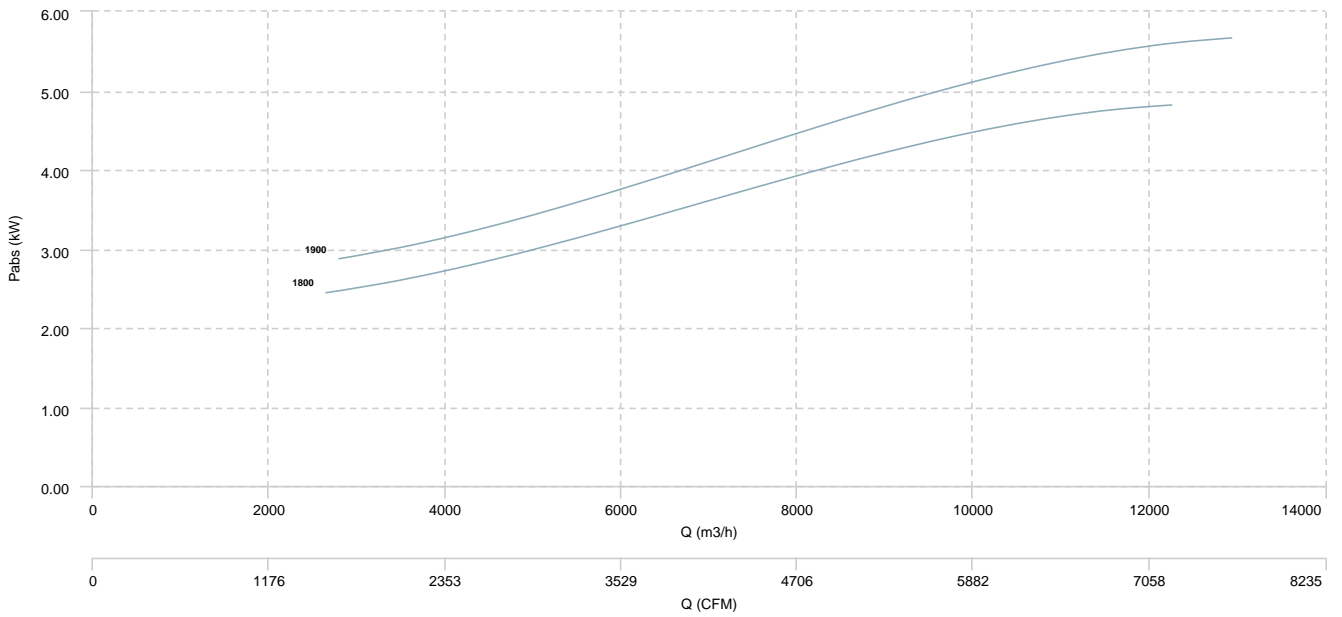

BOX BSTB 500 7,5kW

AIR FLOW - PRESSURE

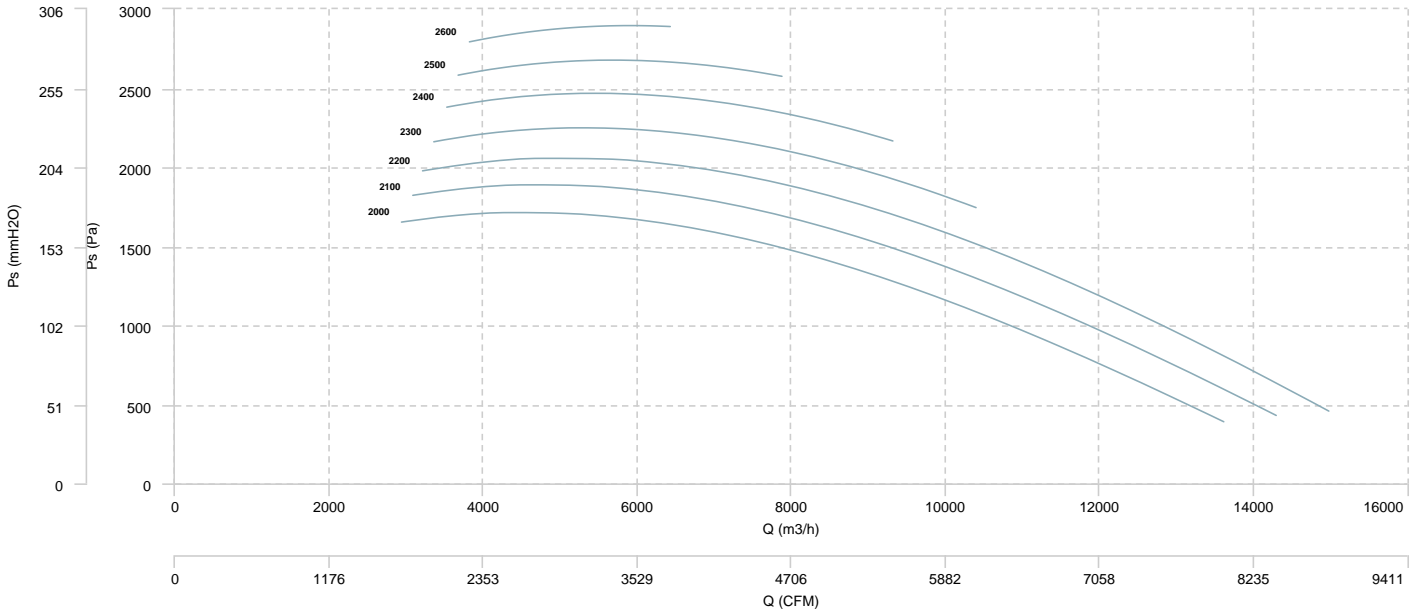

AIR FLOW - ABSORBED POWER

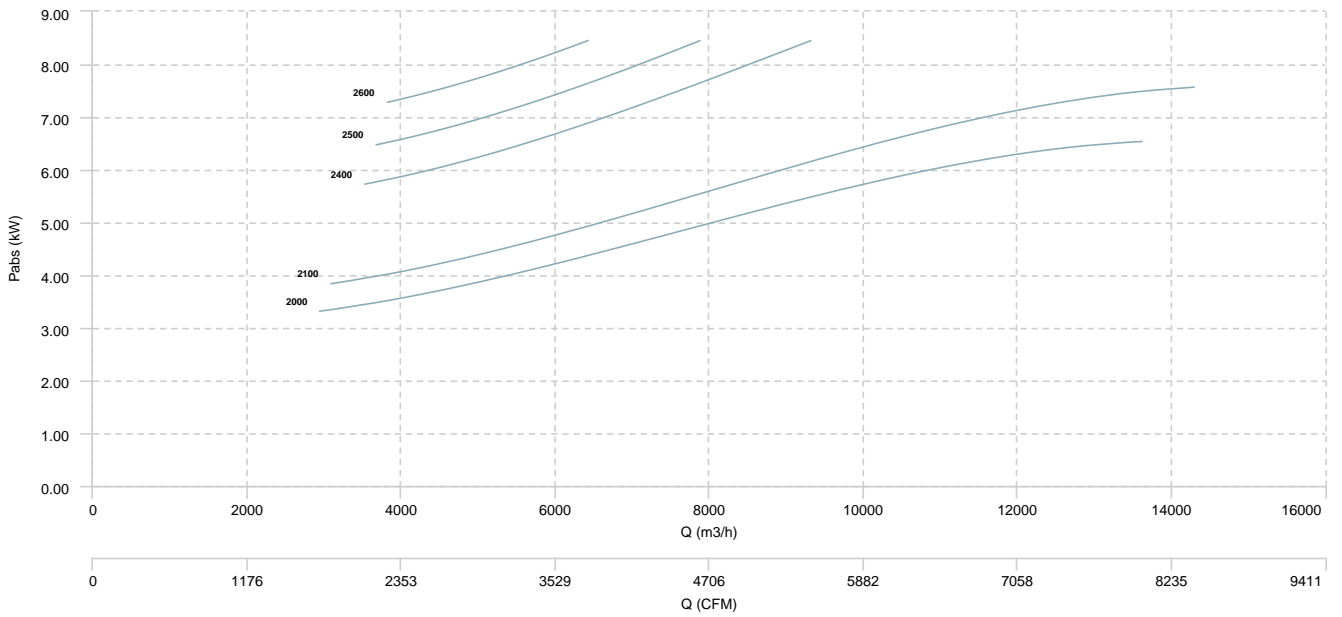

BOX BSTB 560 1,5kW

AIR FLOW - PRESSURE

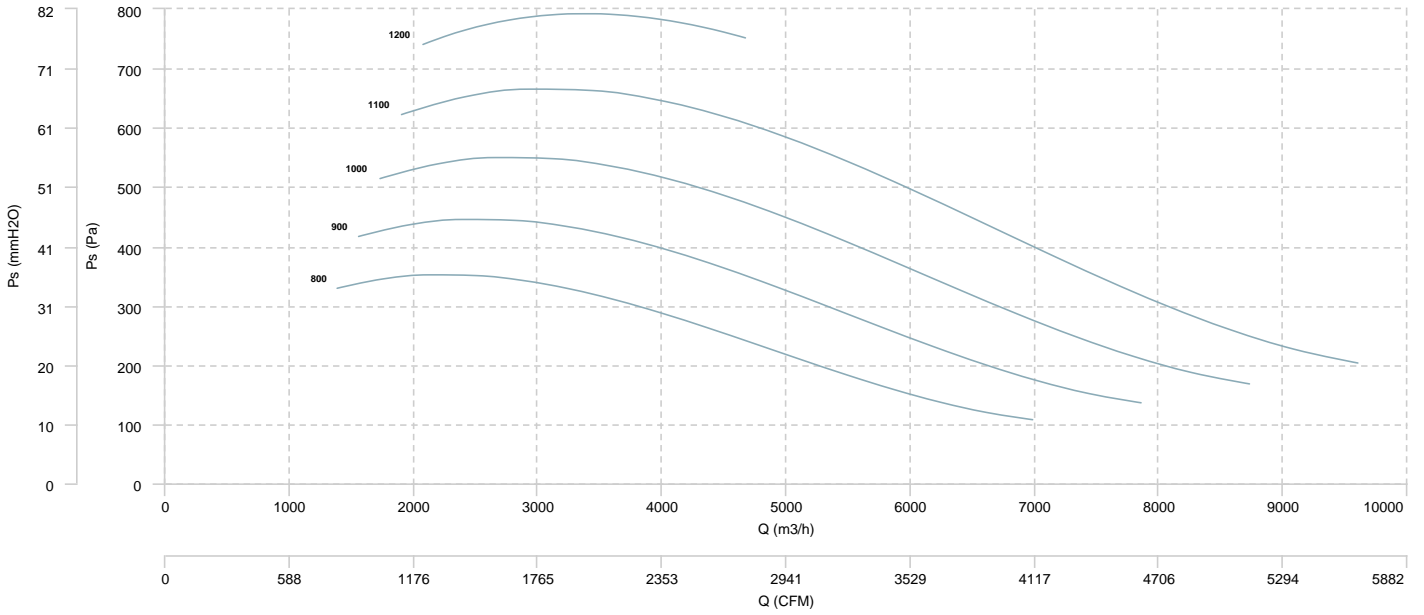

AIR FLOW - ABSORBED POWER

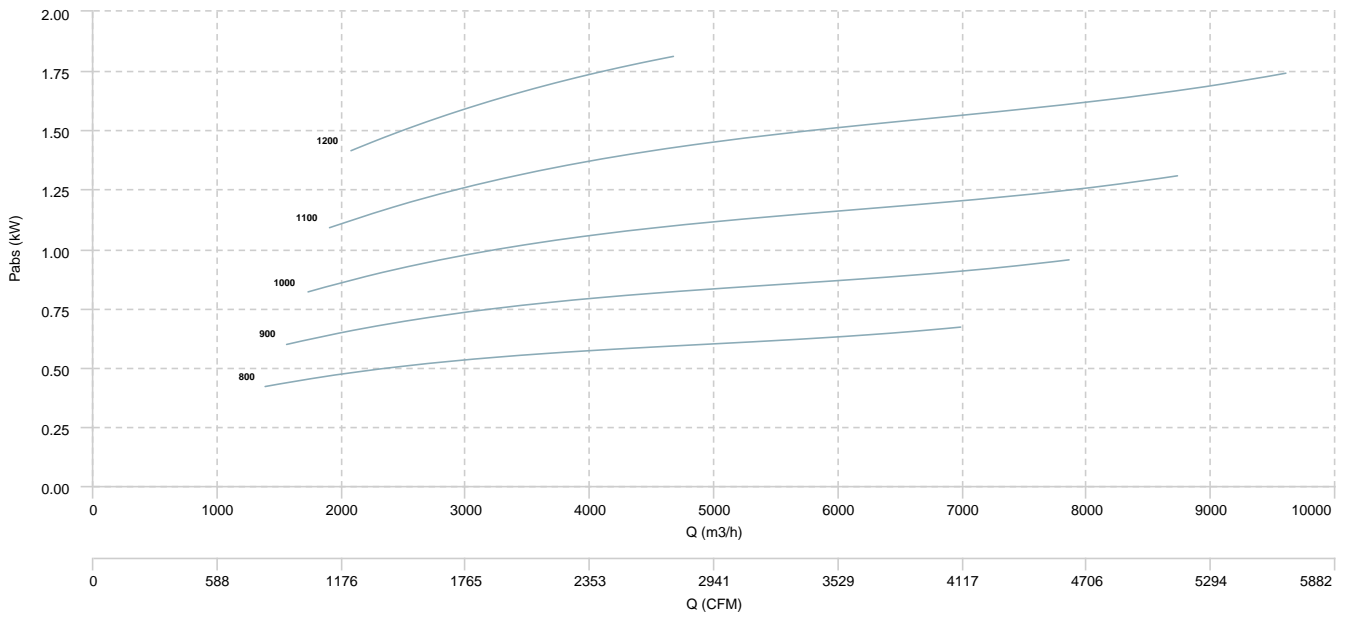

BOX BSTB 560 2,2kW

AIR FLOW - PRESSURE

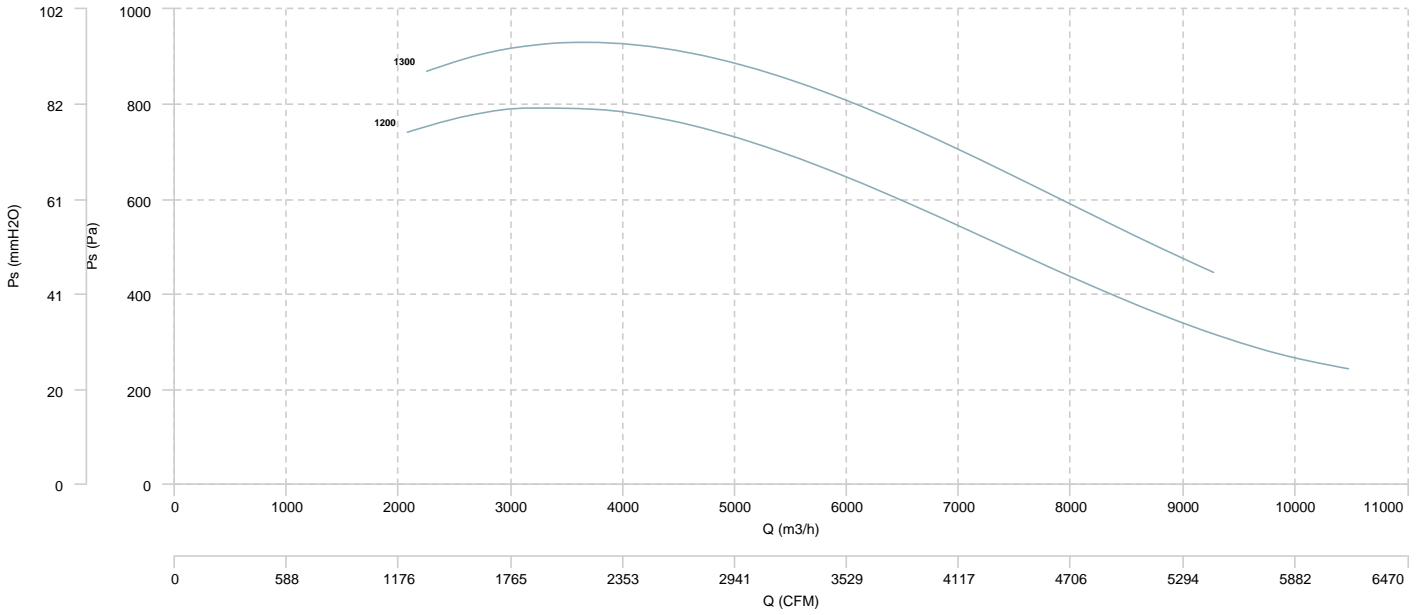

AIR FLOW - ABSORBED POWER

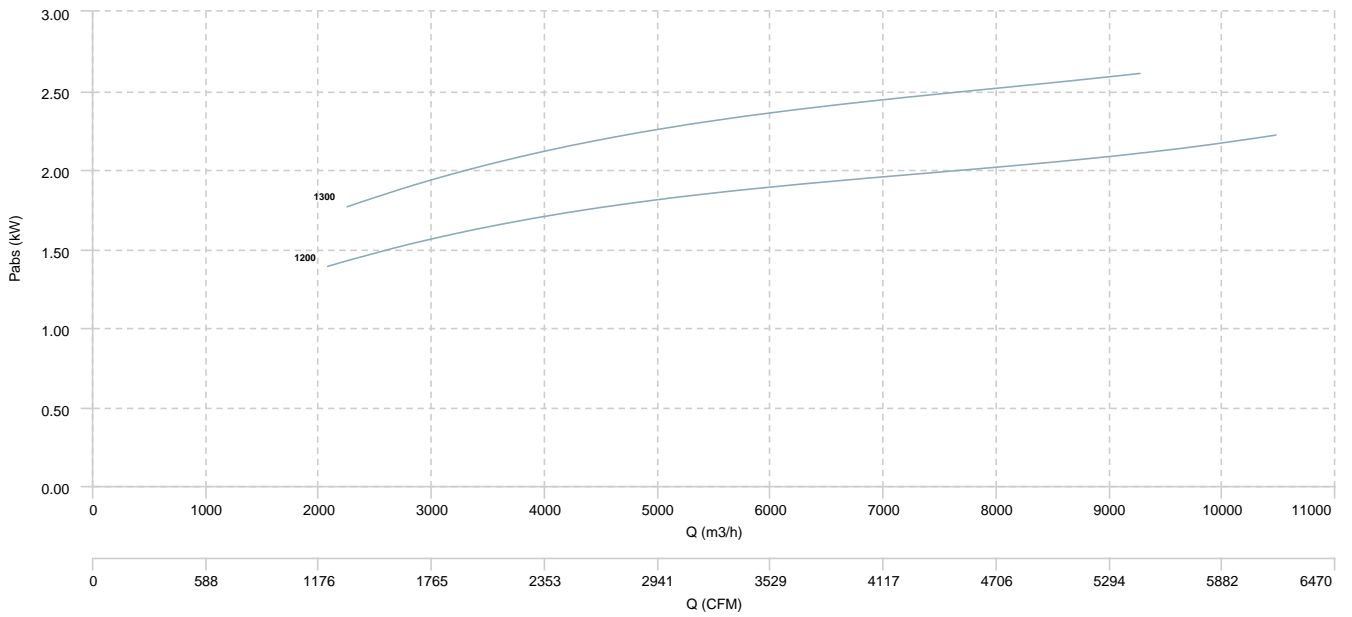

BOX BSTB 560 3kW

AIR FLOW - PRESSURE

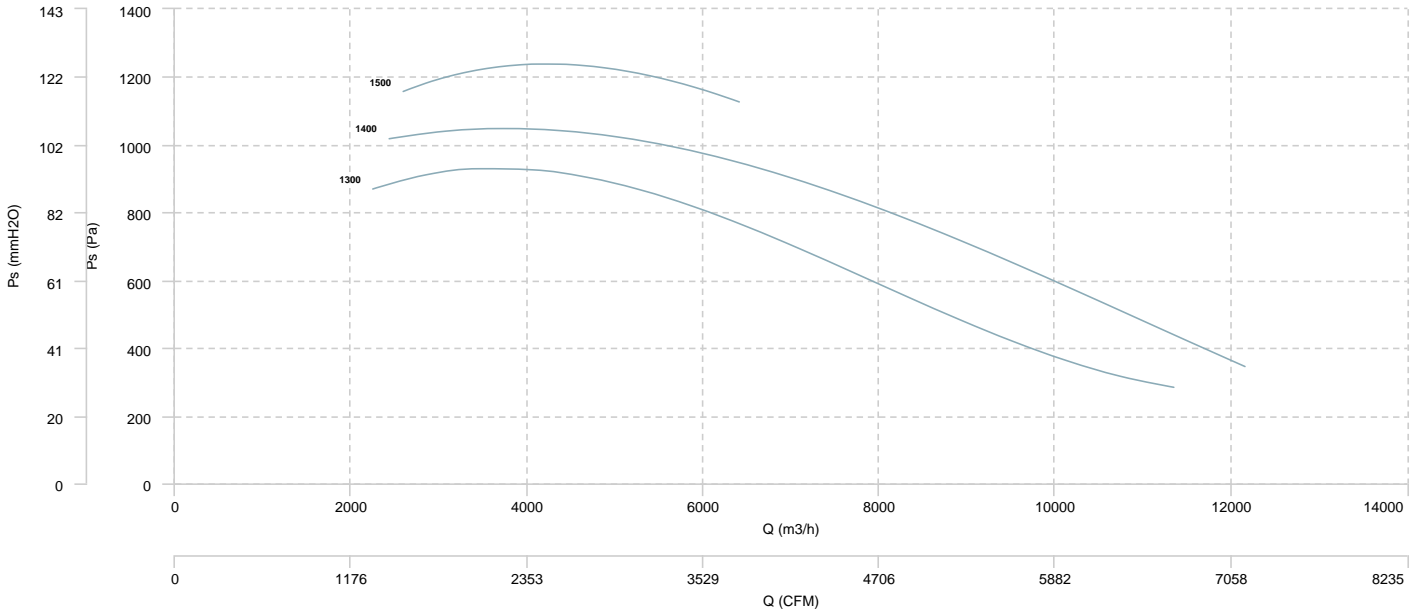

AIR FLOW - ABSORBED POWER

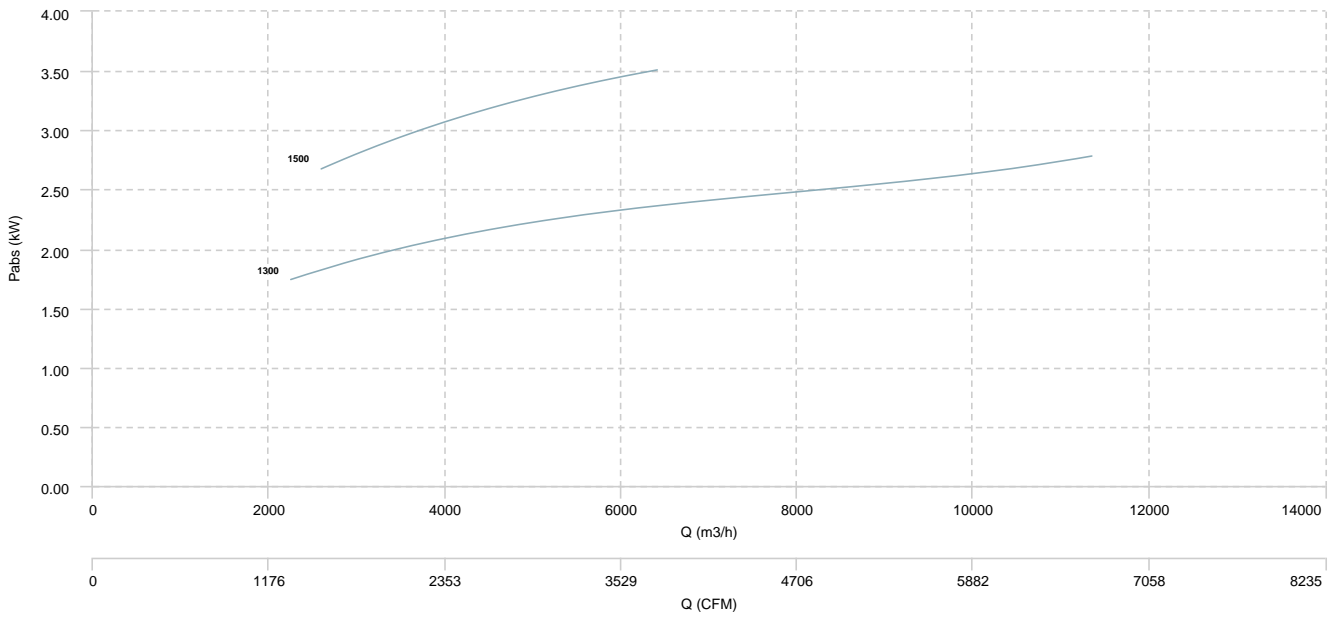

BOX BSTB 560 4kW

AIR FLOW - PRESSURE

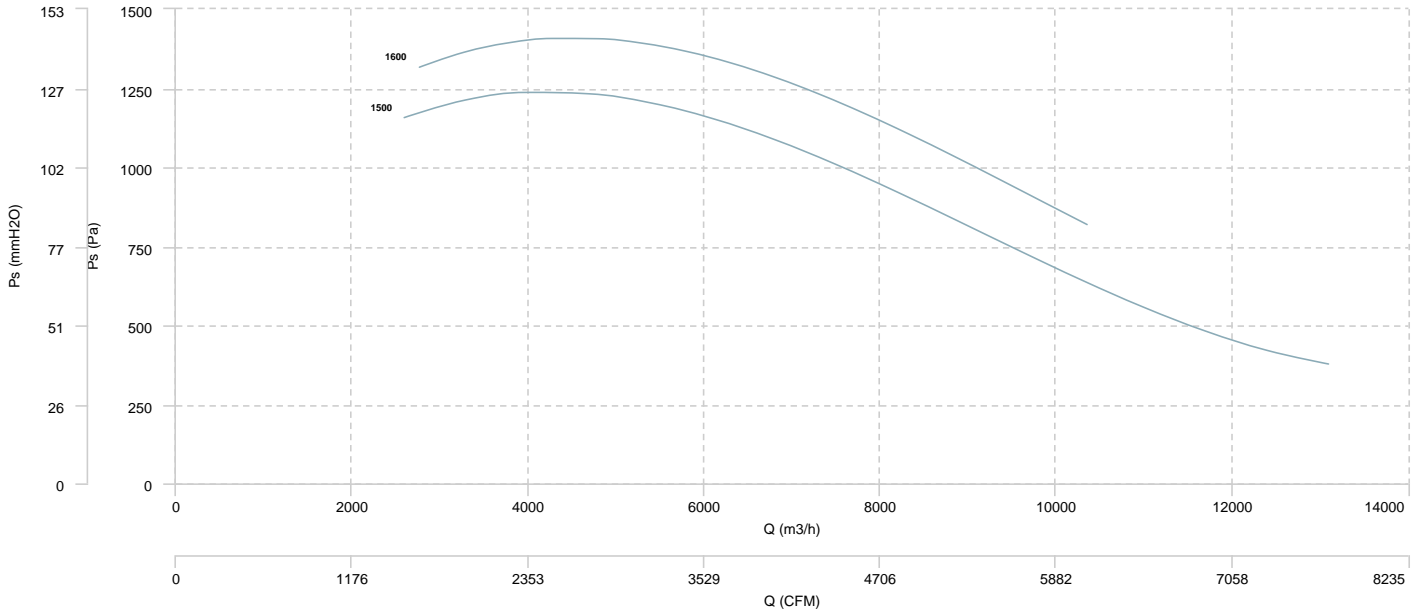

AIR FLOW - ABSORBED POWER

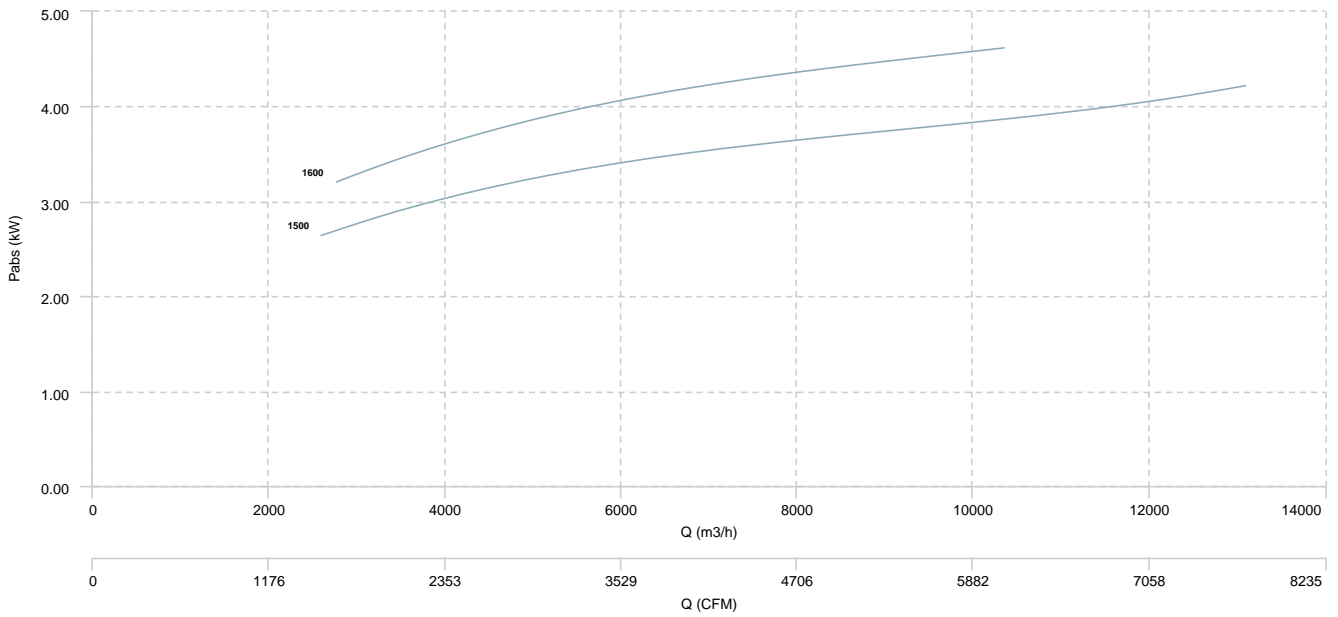

BOX BSTB 560 5,5kW

AIR FLOW - PRESSURE

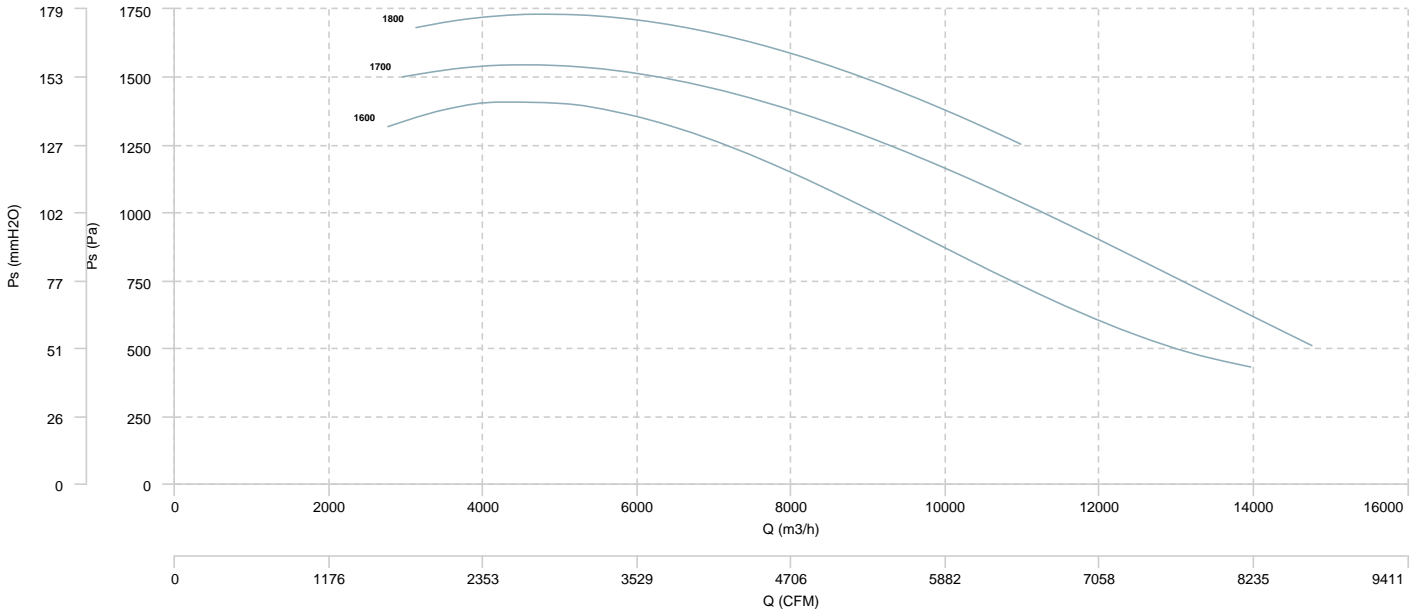

AIR FLOW - ABSORBED POWER

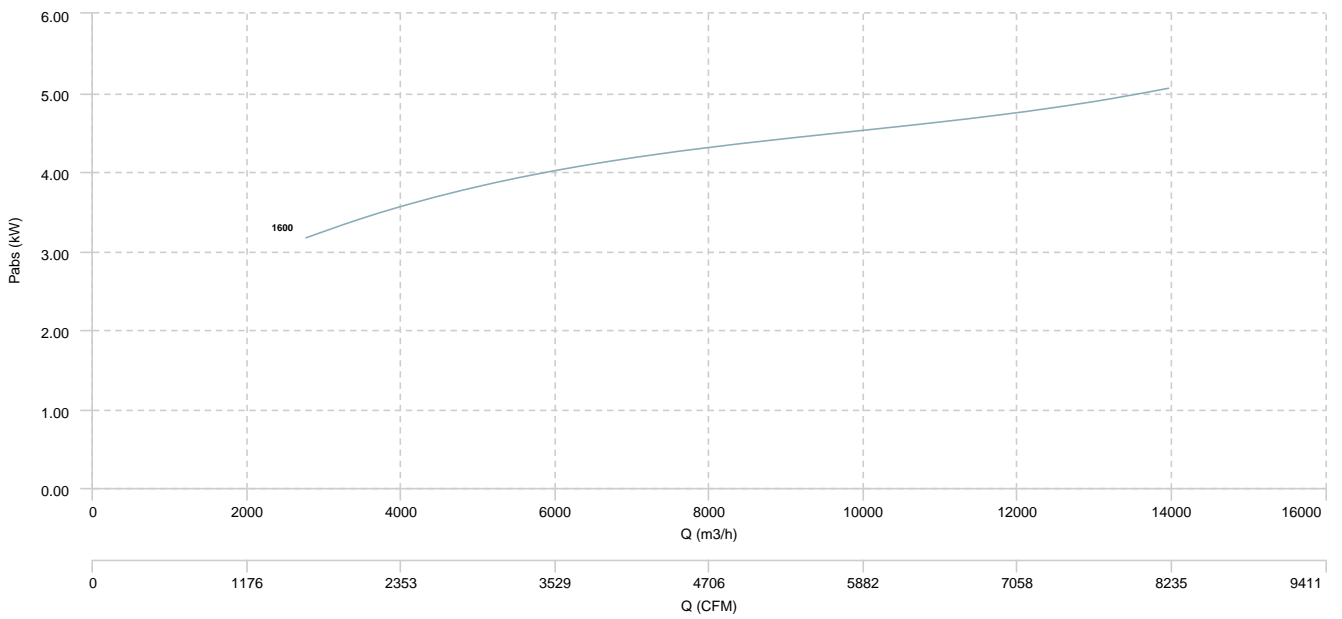

BOX BSTB 560 7,5kW

AIR FLOW - PRESSURE

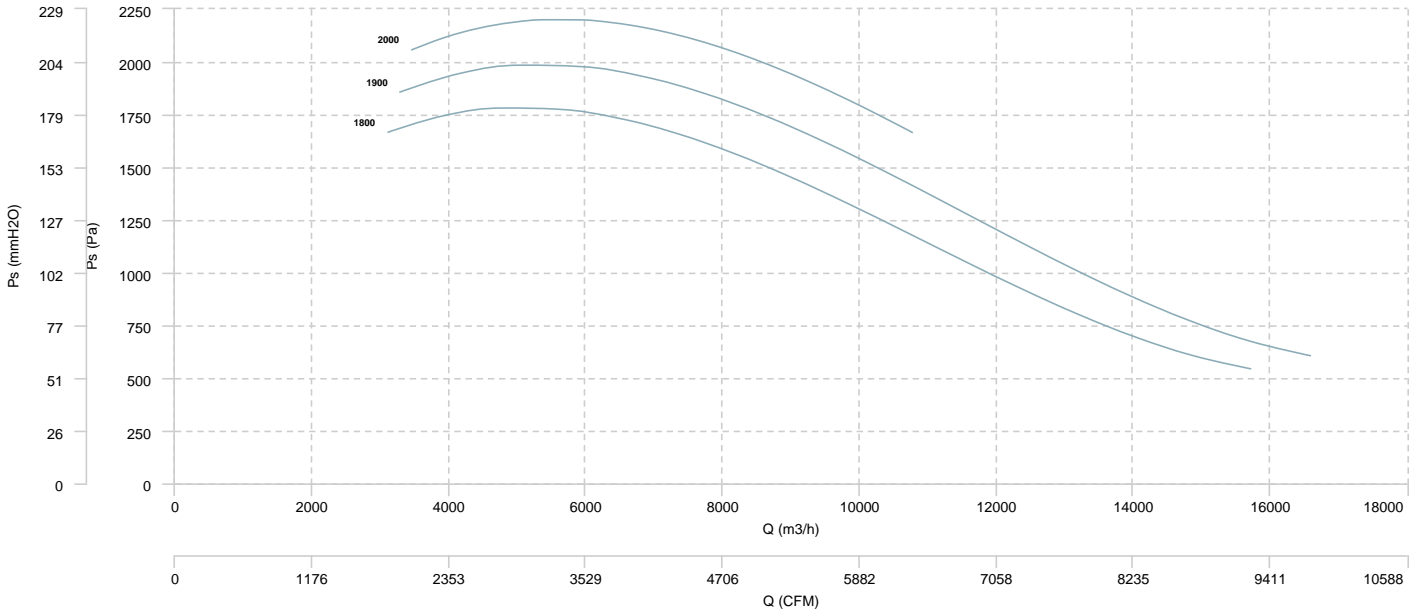

AIR FLOW - ABSORBED POWER

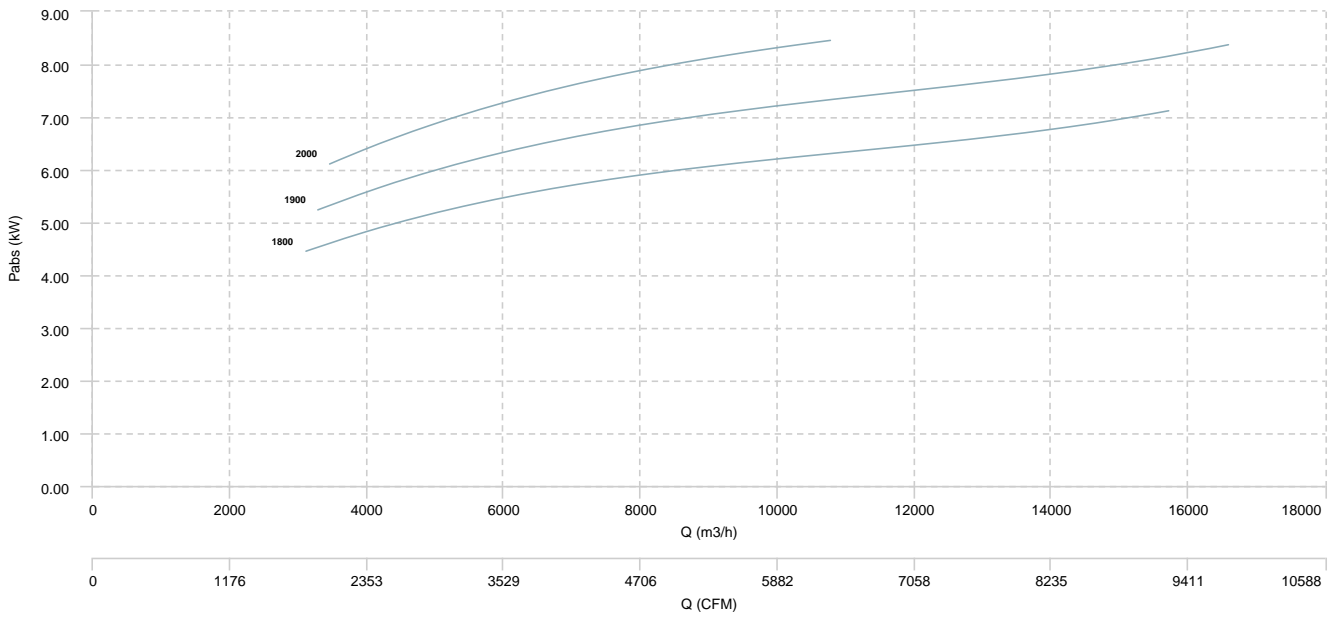

BOX BSTB 560 11kW

AIR FLOW - PRESSURE

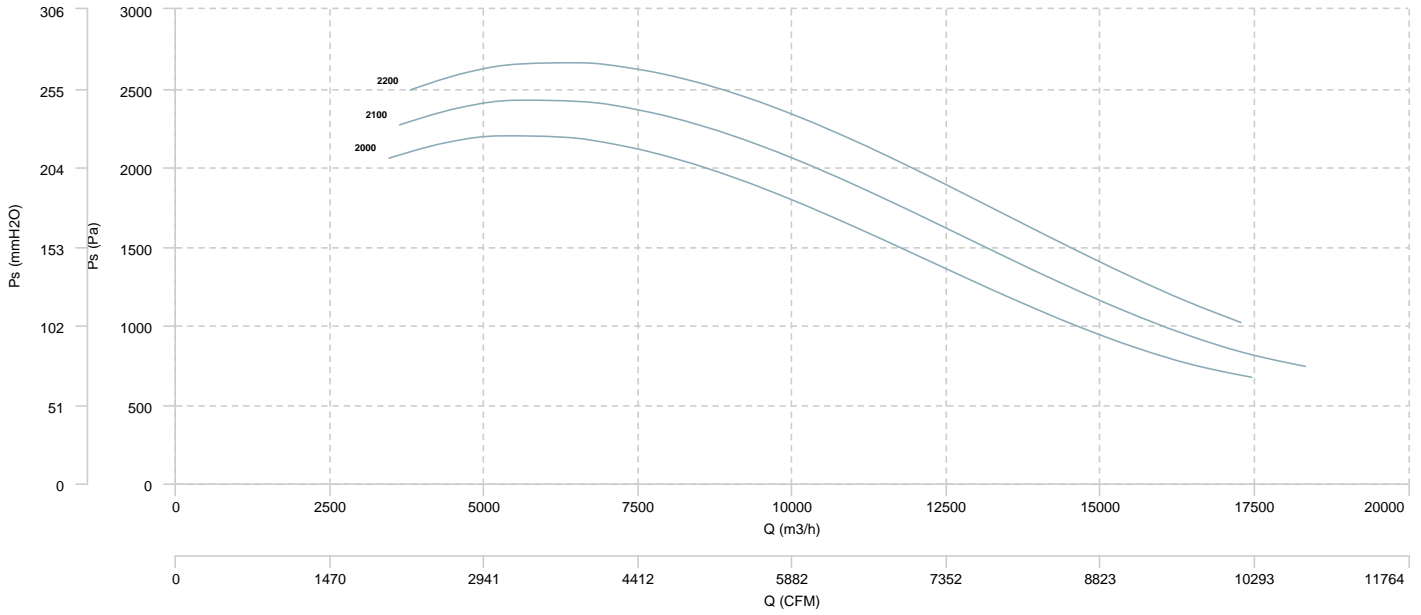

AIR FLOW - ABSORBED POWER

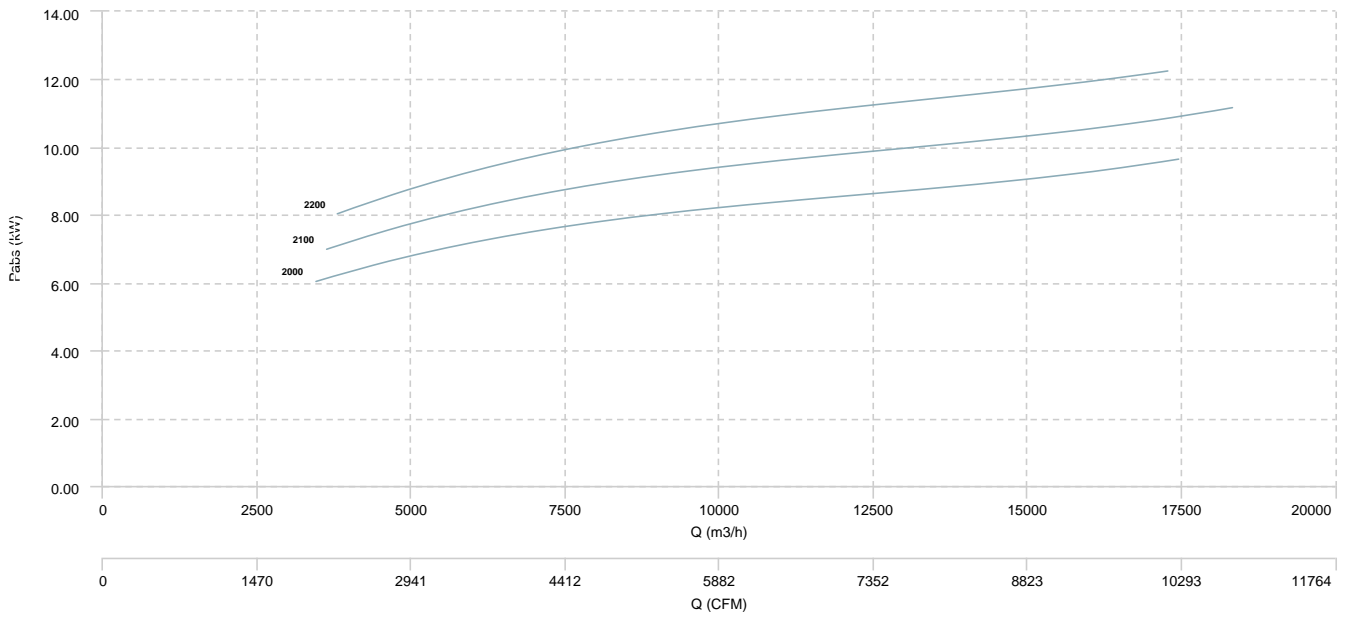

BOX BSTB 630 2,2kW

AIR FLOW - PRESSURE

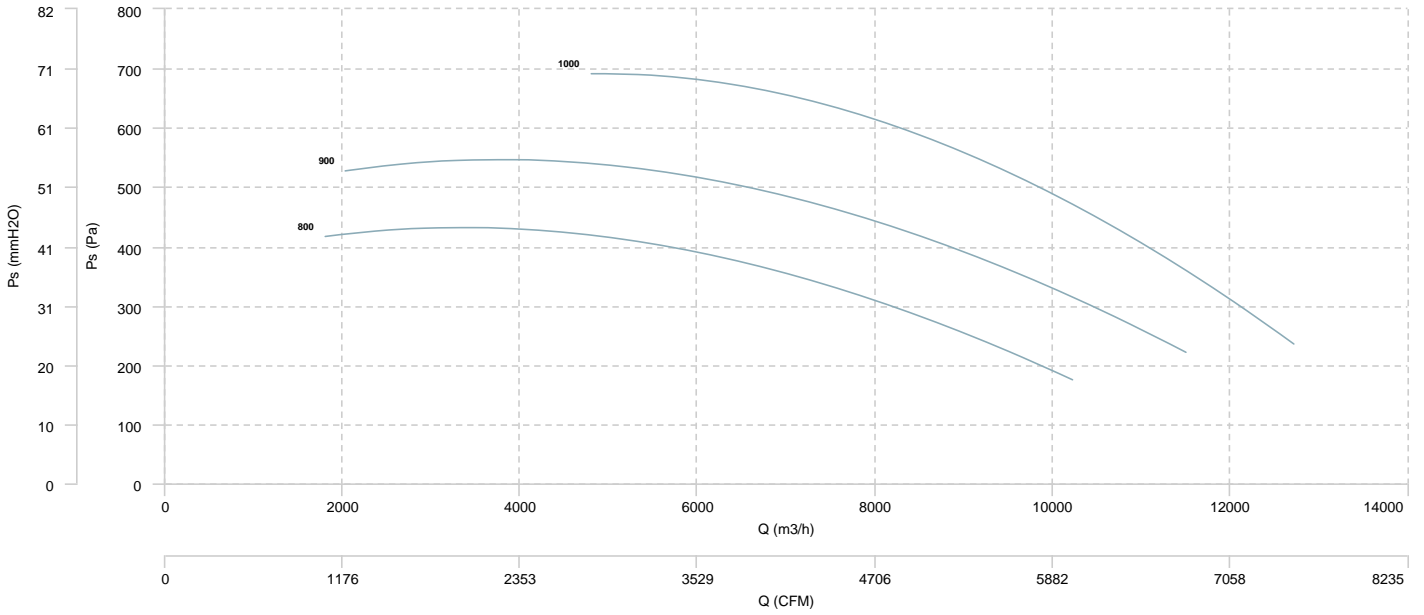

AIR FLOW - ABSORBED POWER

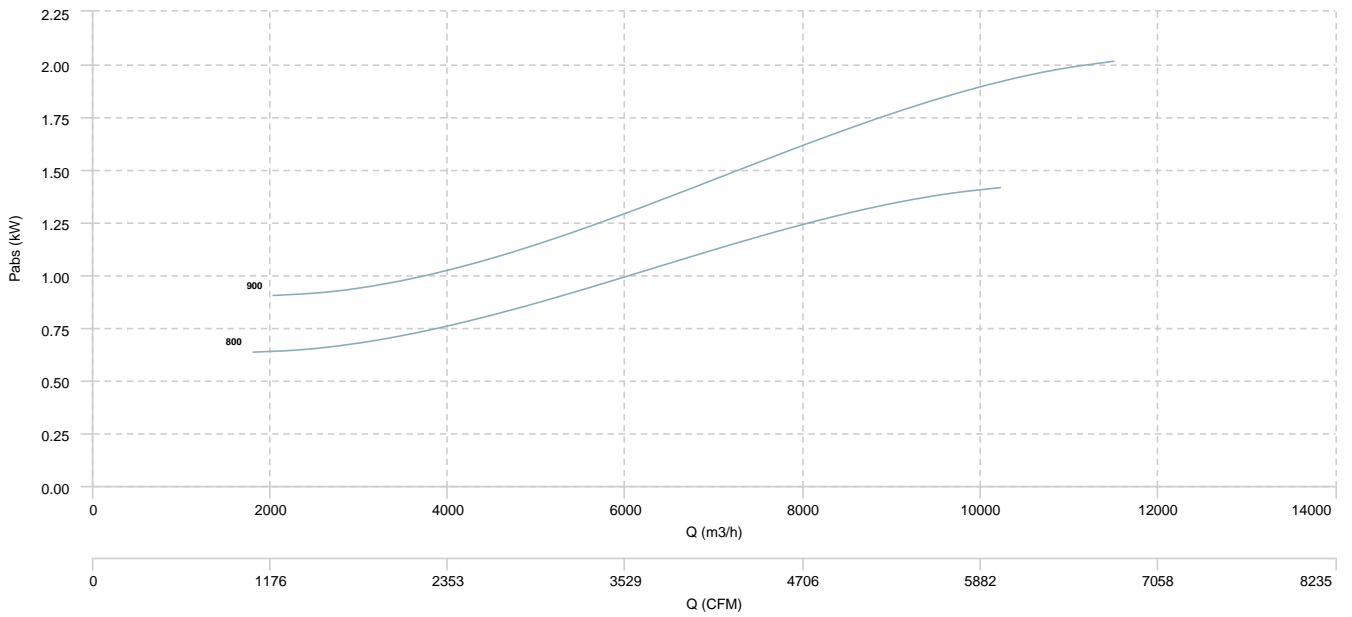

BOX BSTB 630 3kW

AIR FLOW - PRESSURE

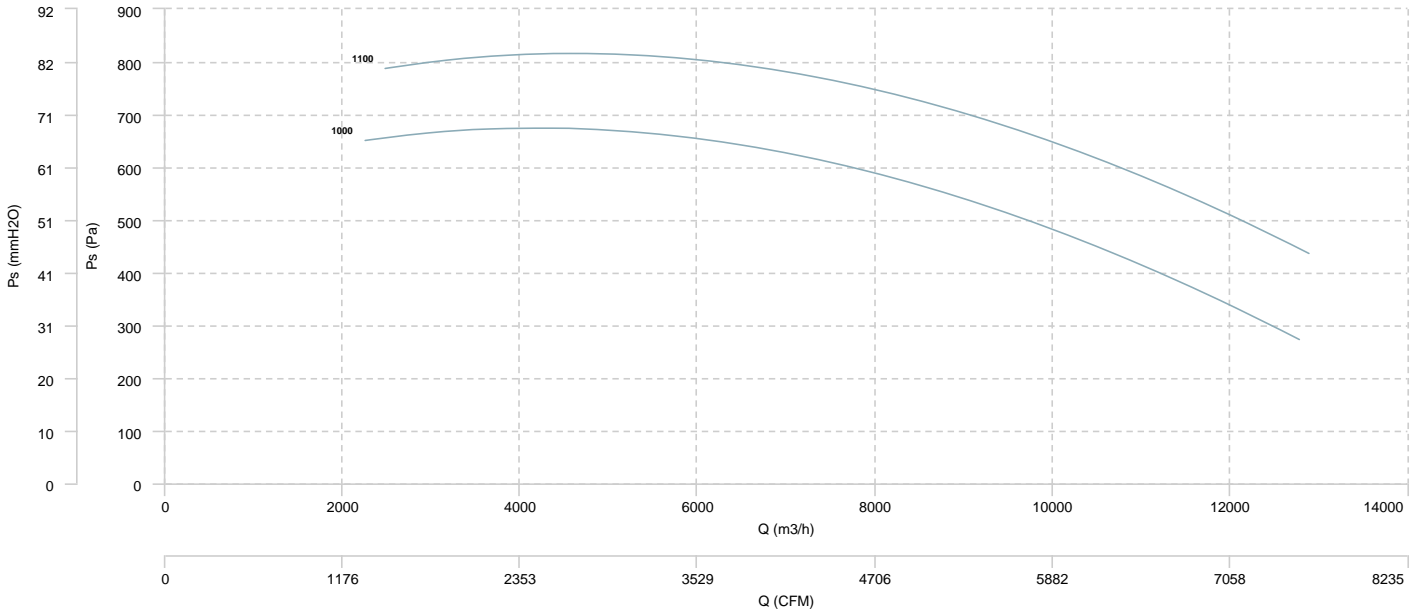

AIR FLOW - ABSORBED POWER

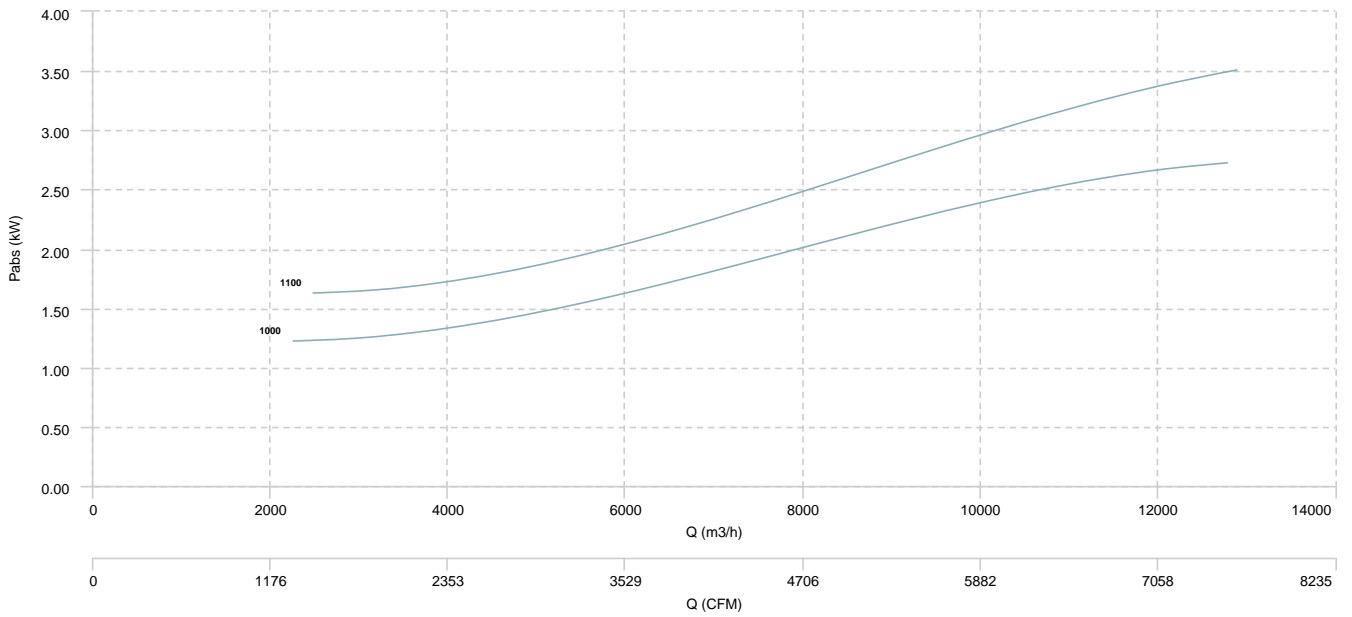

BOX BSTB 630 4kW

AIR FLOW - PRESSURE

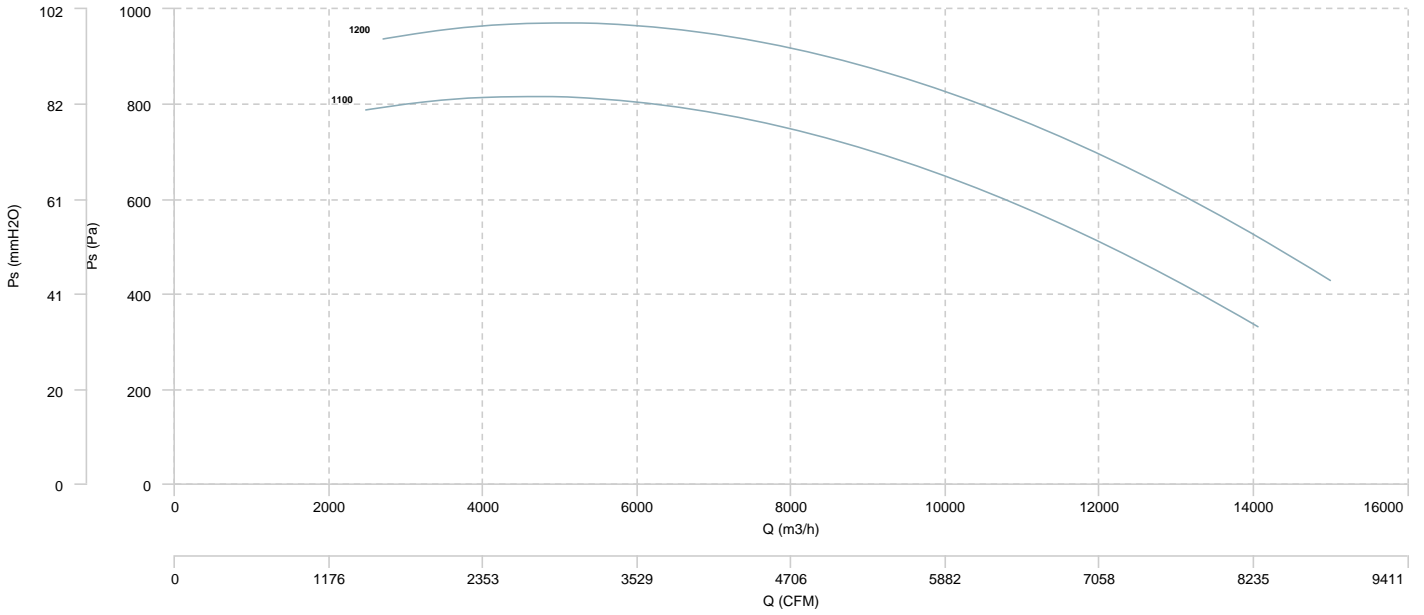

AIR FLOW - ABSORBED POWER

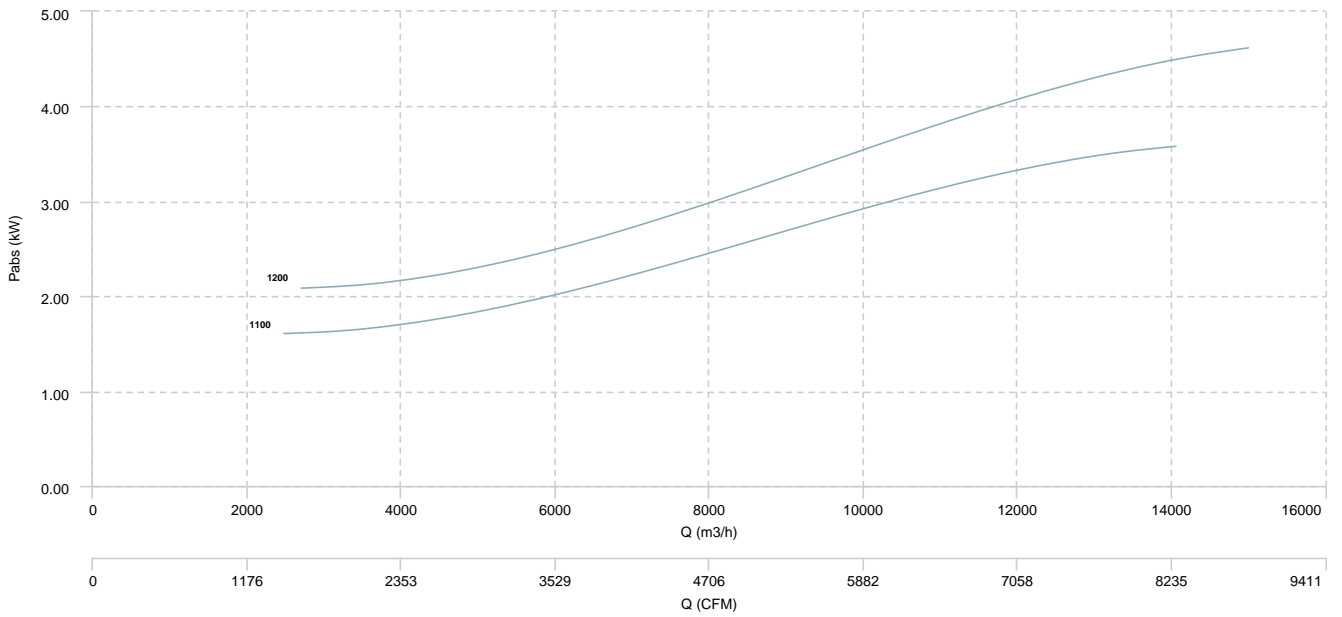

BOX BSTB 630 5,5kW

AIR FLOW - PRESSURE

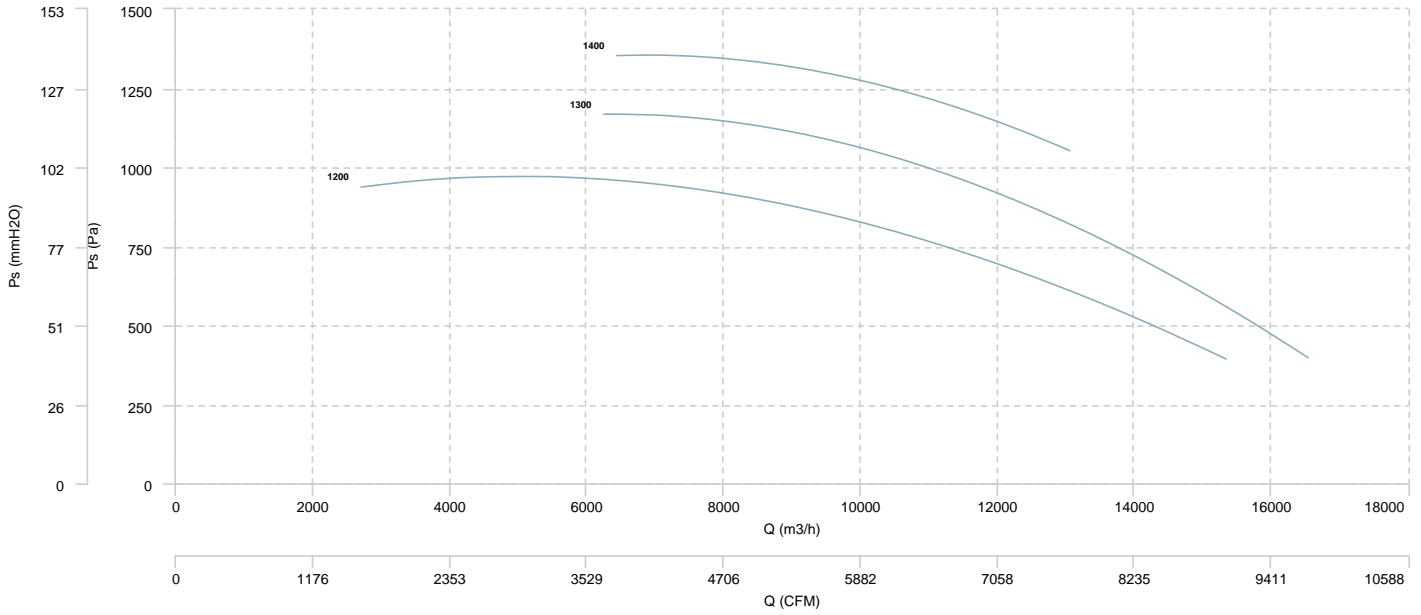

AIR FLOW - ABSORBED POWER

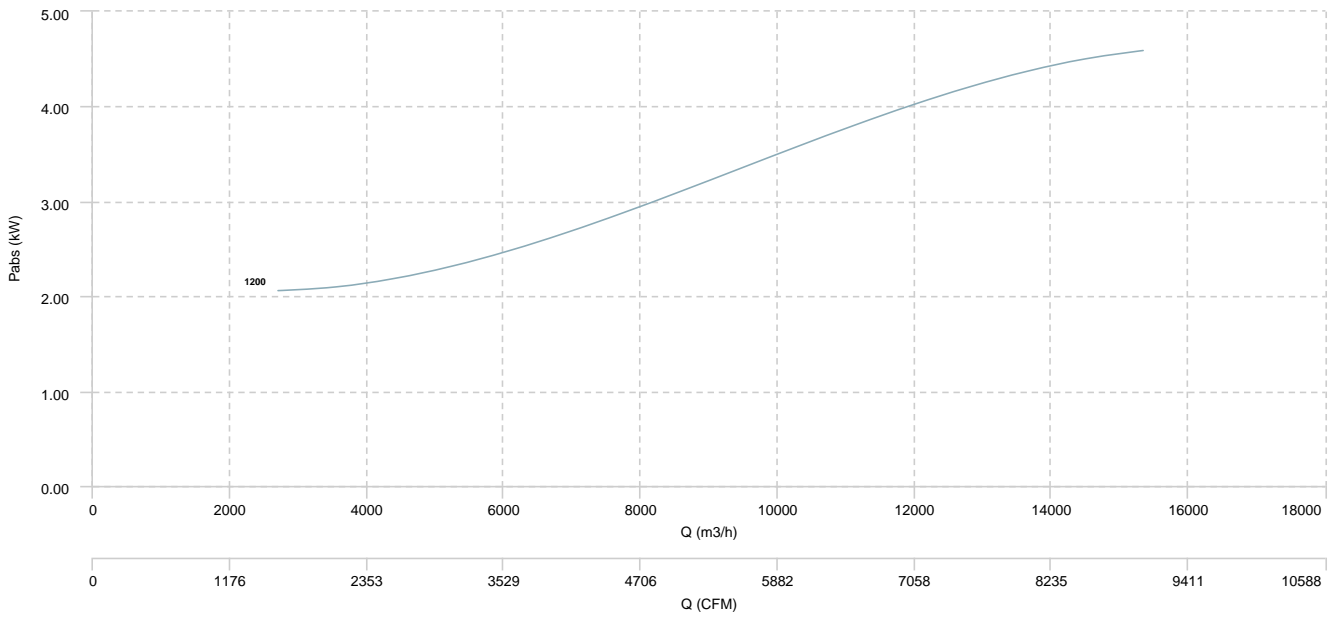

BOX BSTB 630 7,5kW

AIR FLOW - PRESSURE

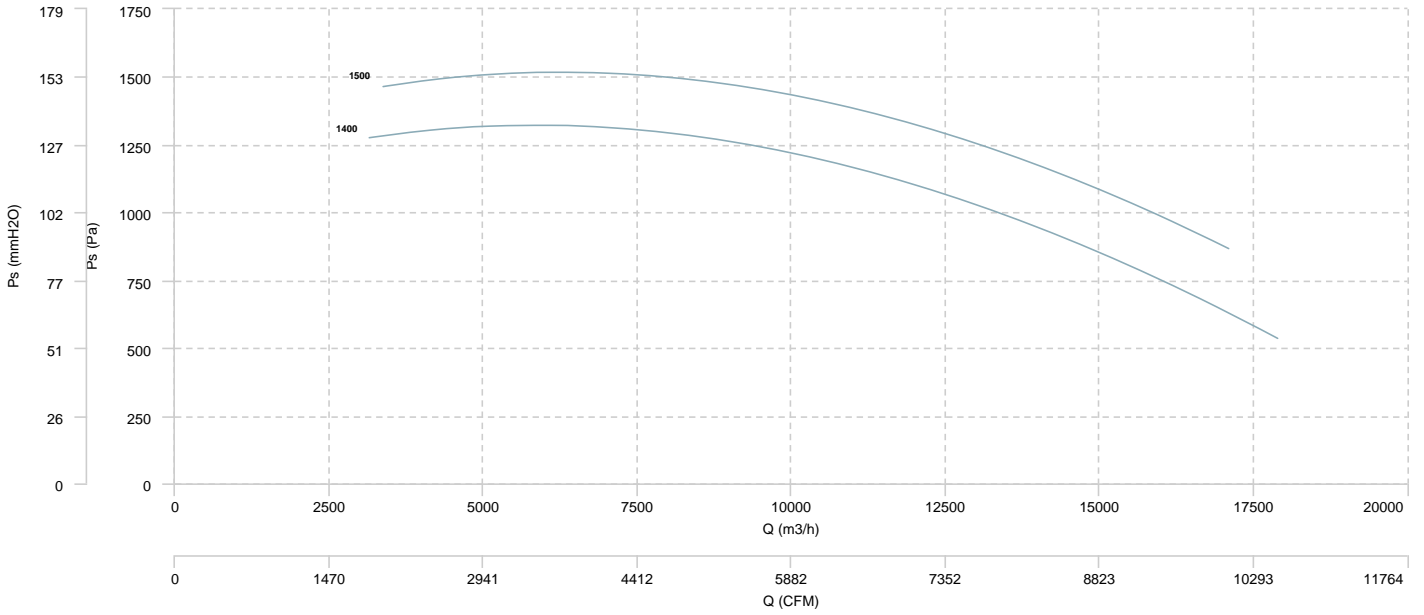

AIR FLOW - ABSORBED POWER

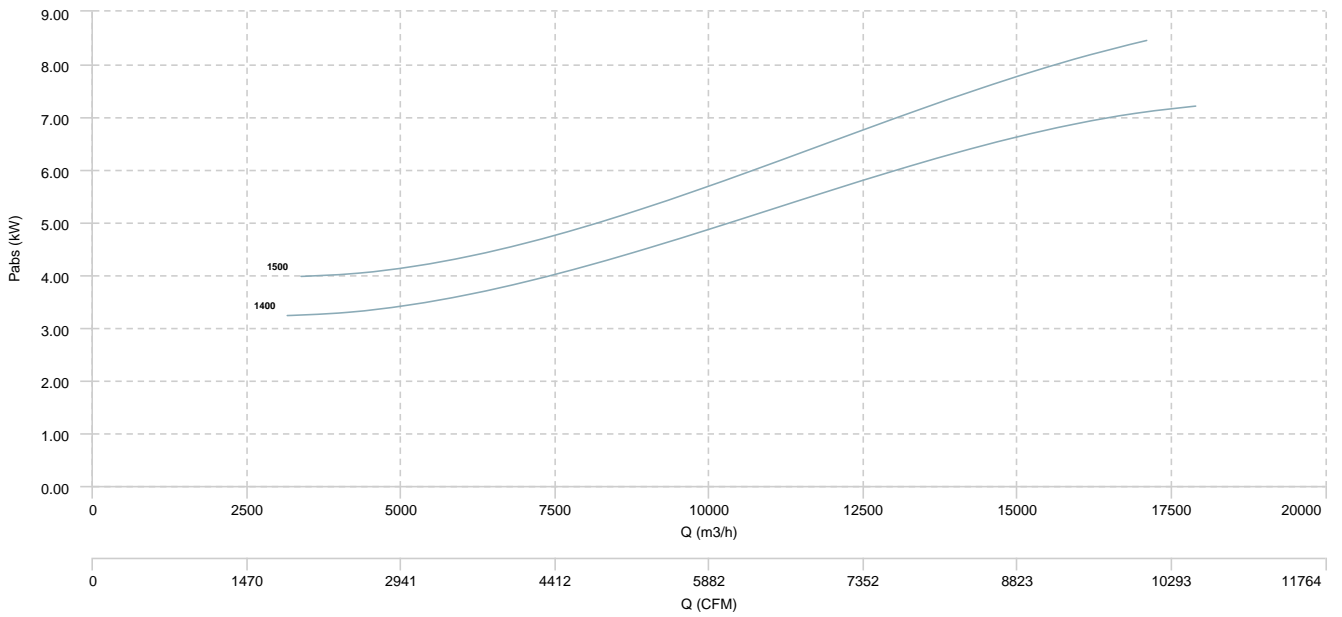

BOX BSTB 630 11kW

AIR FLOW - PRESSURE

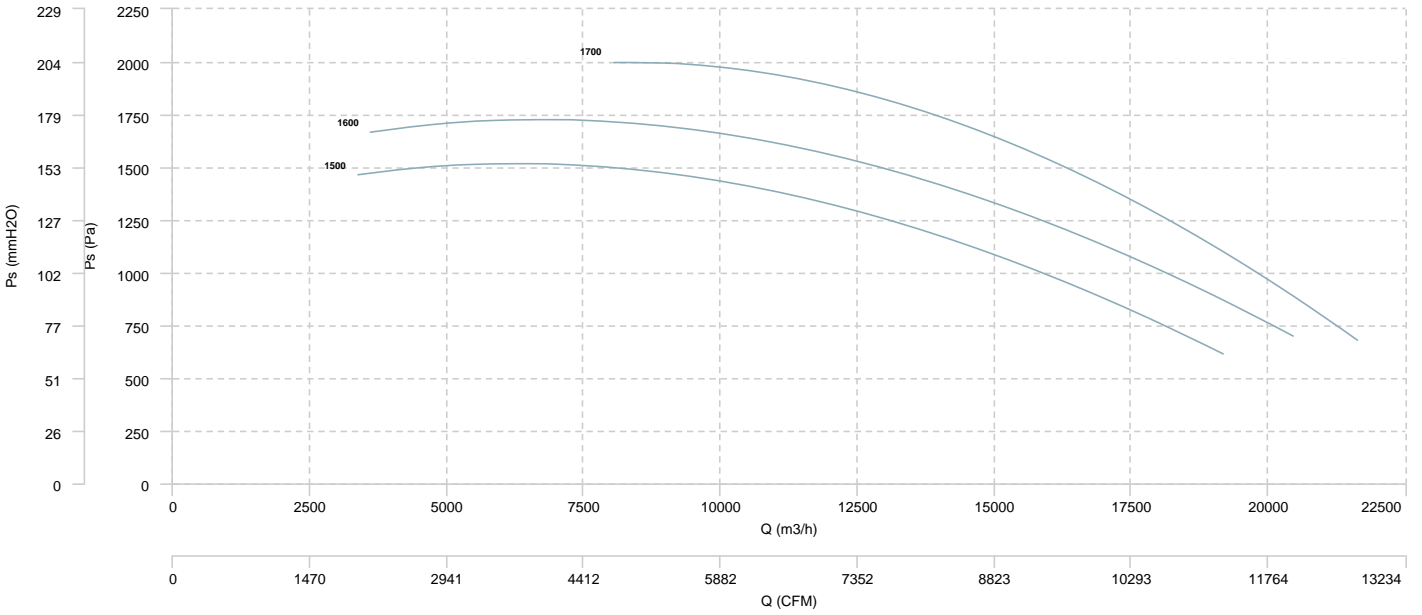

AIR FLOW - ABSORBED POWER

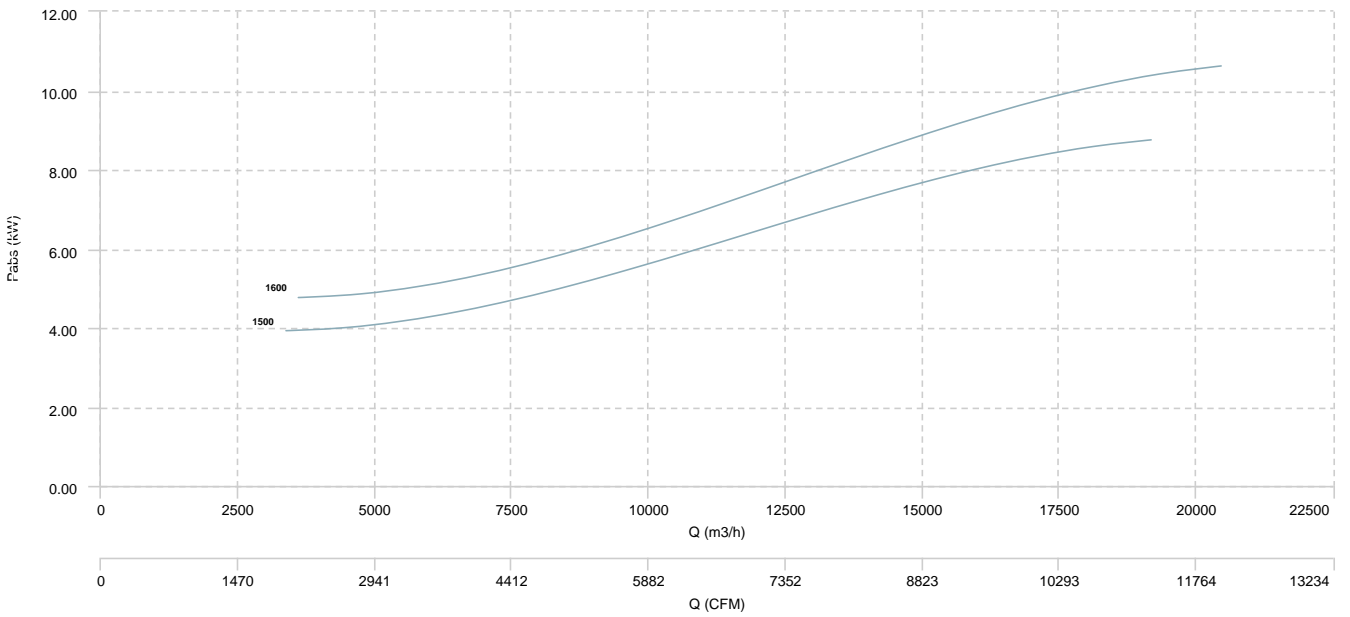

BOX BSTB 630 15kW

AIR FLOW - PRESSURE

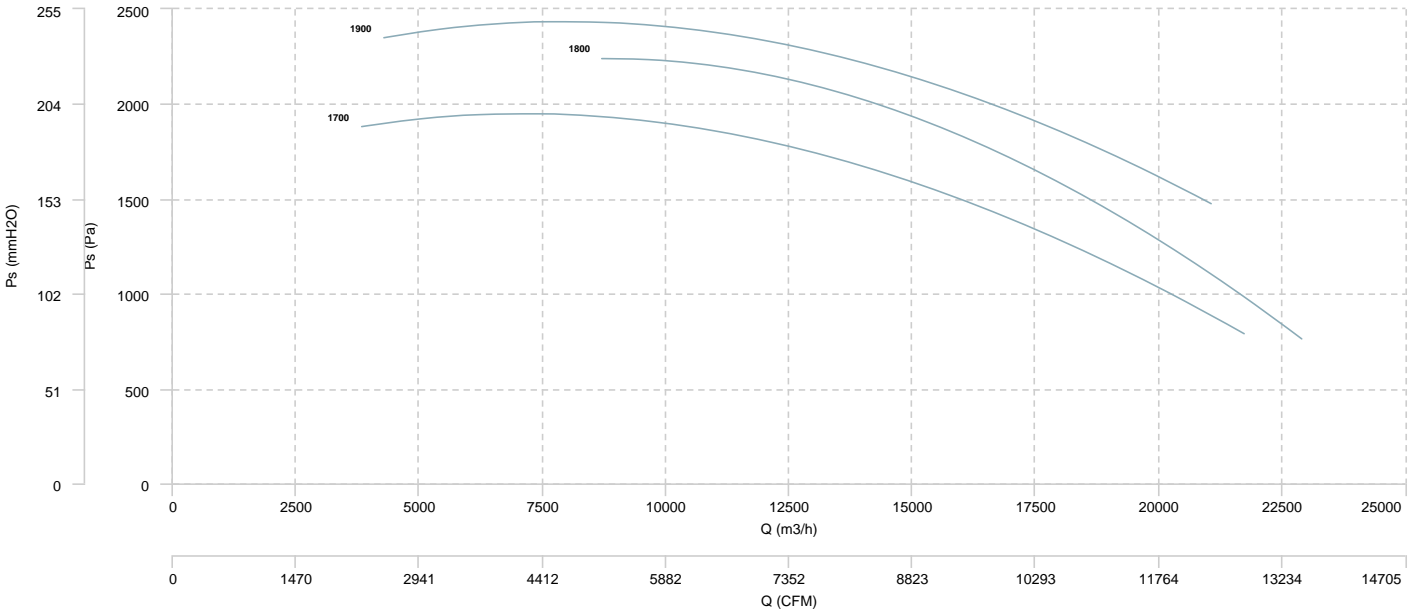

AIR FLOW - ABSORBED POWER

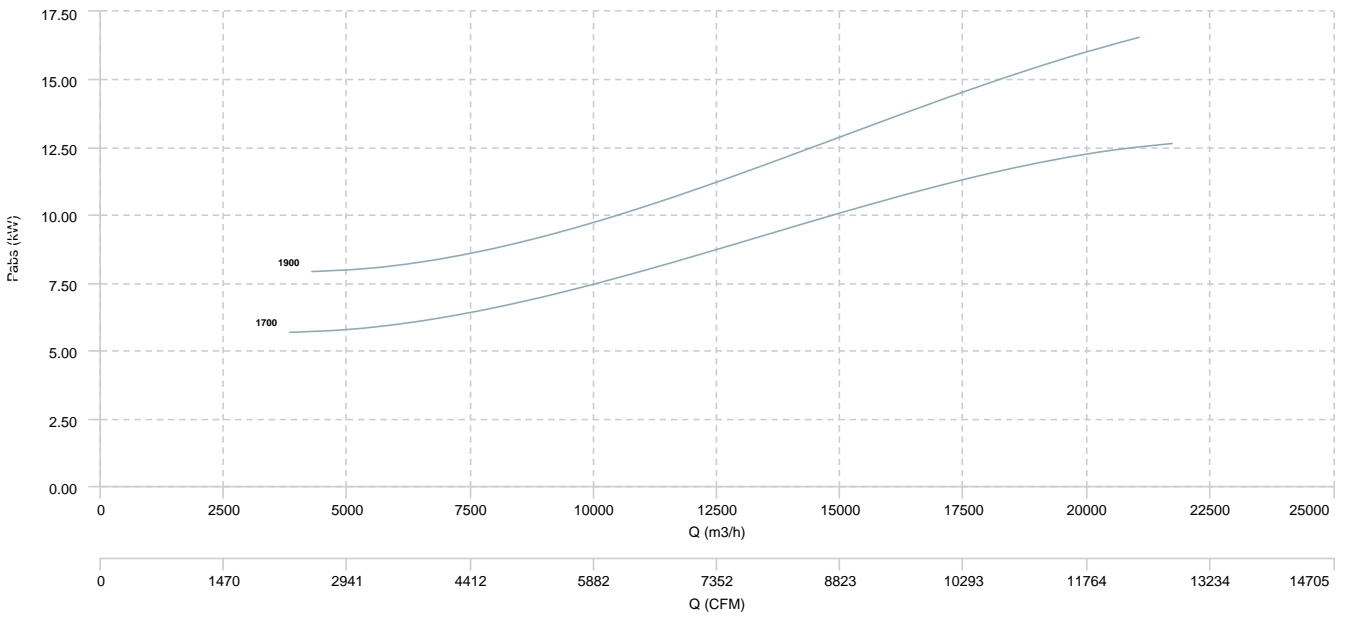

BOX BSTB 710 3kW

AIR FLOW - PRESSURE

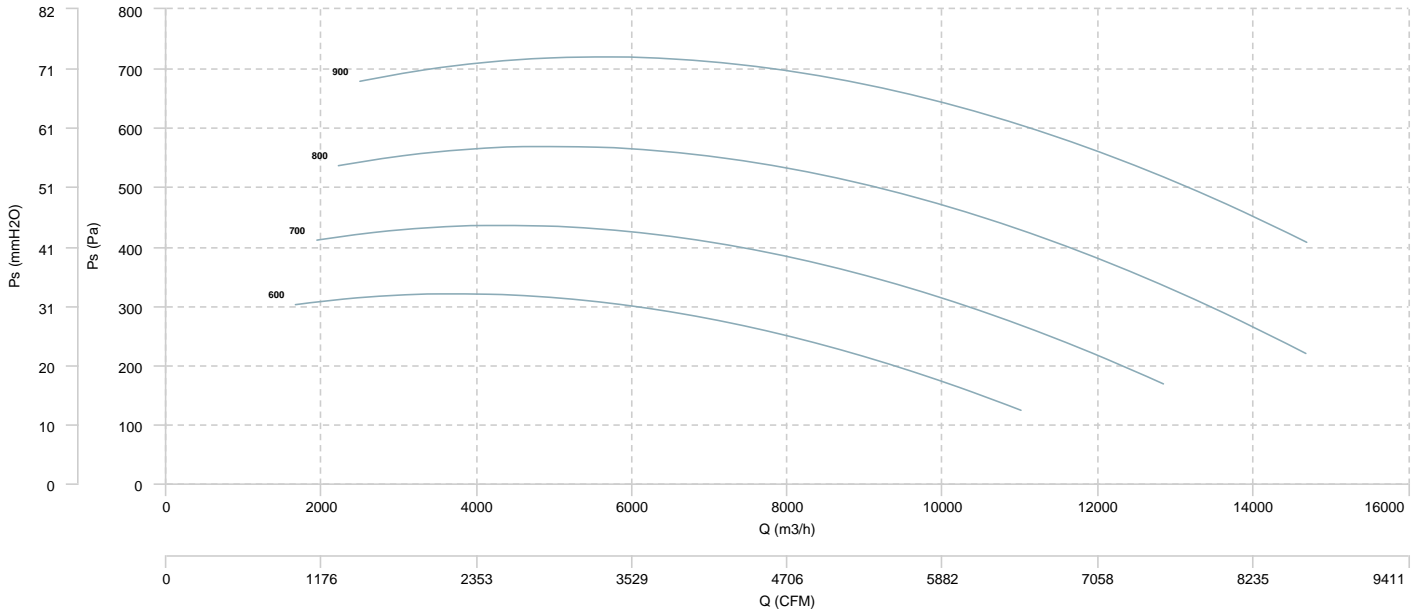

AIR FLOW - ABSORBED POWER

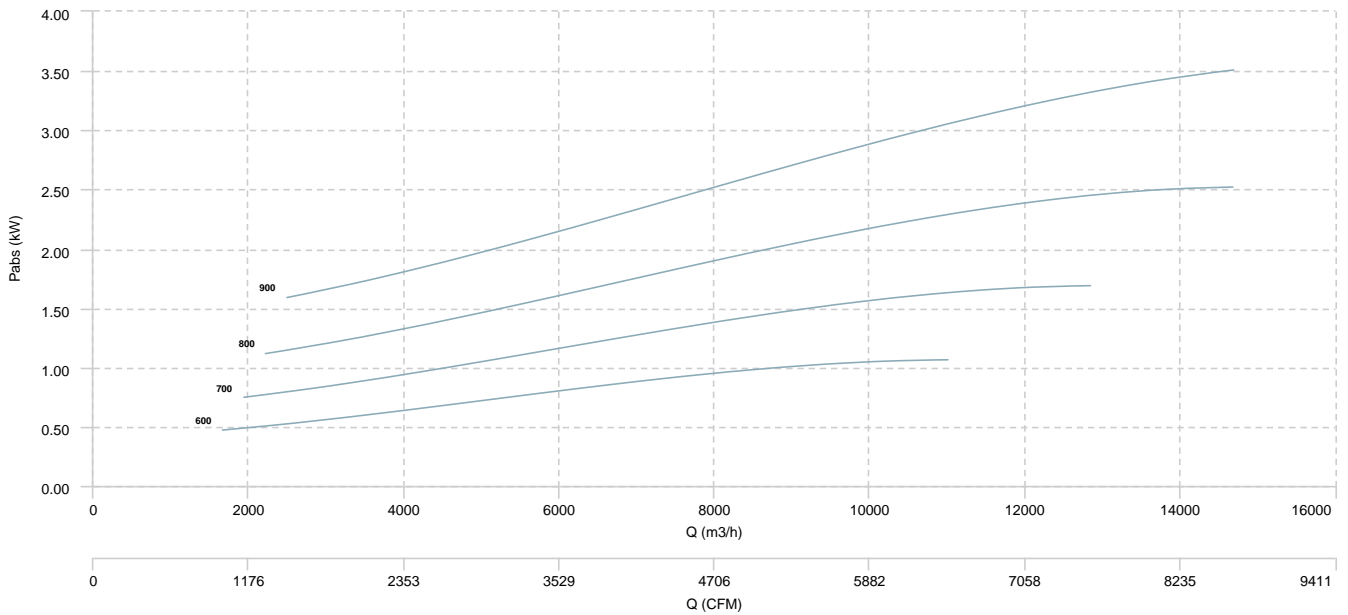

BOX BSTB 710 4kW

AIR FLOW - PRESSURE

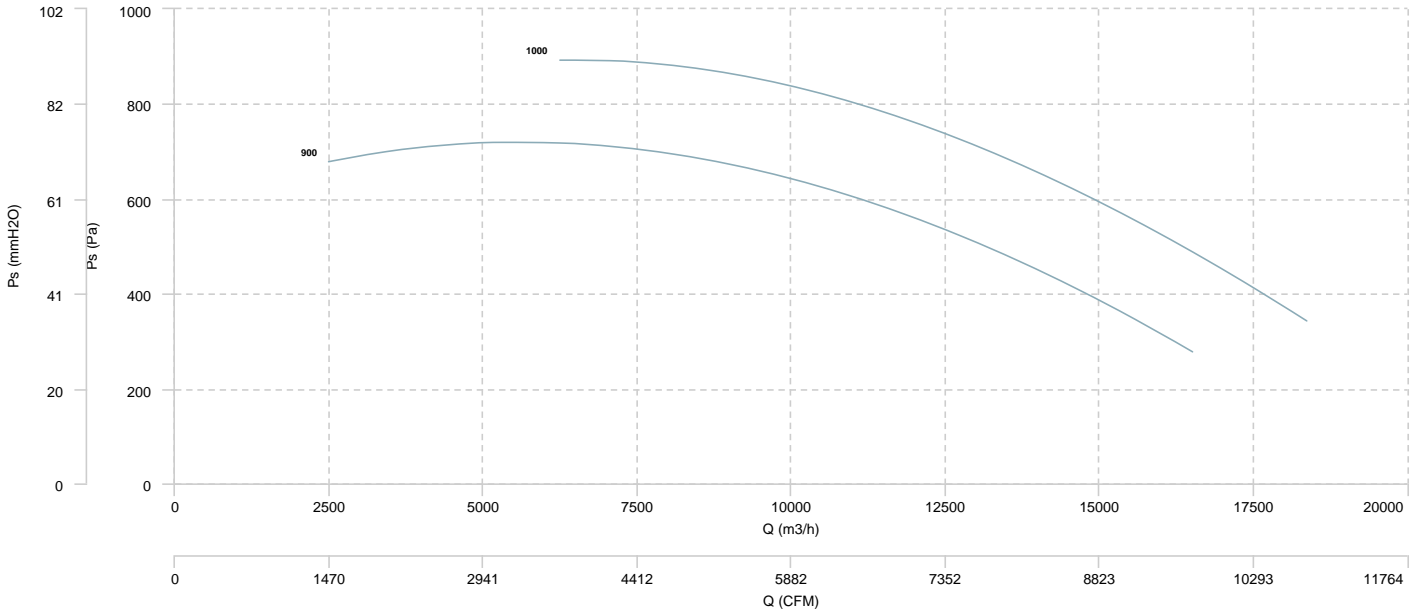

AIR FLOW - ABSORBED POWER

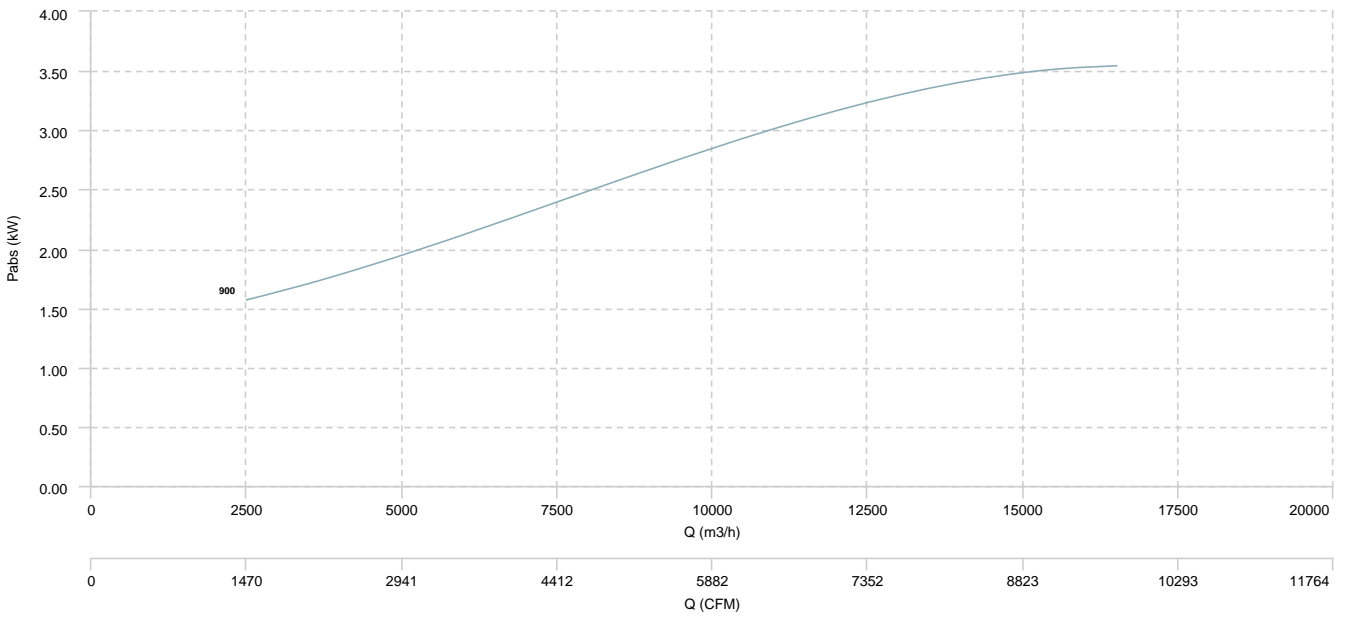

BOX BSTB 710 5,5kW

AIR FLOW - PRESSURE

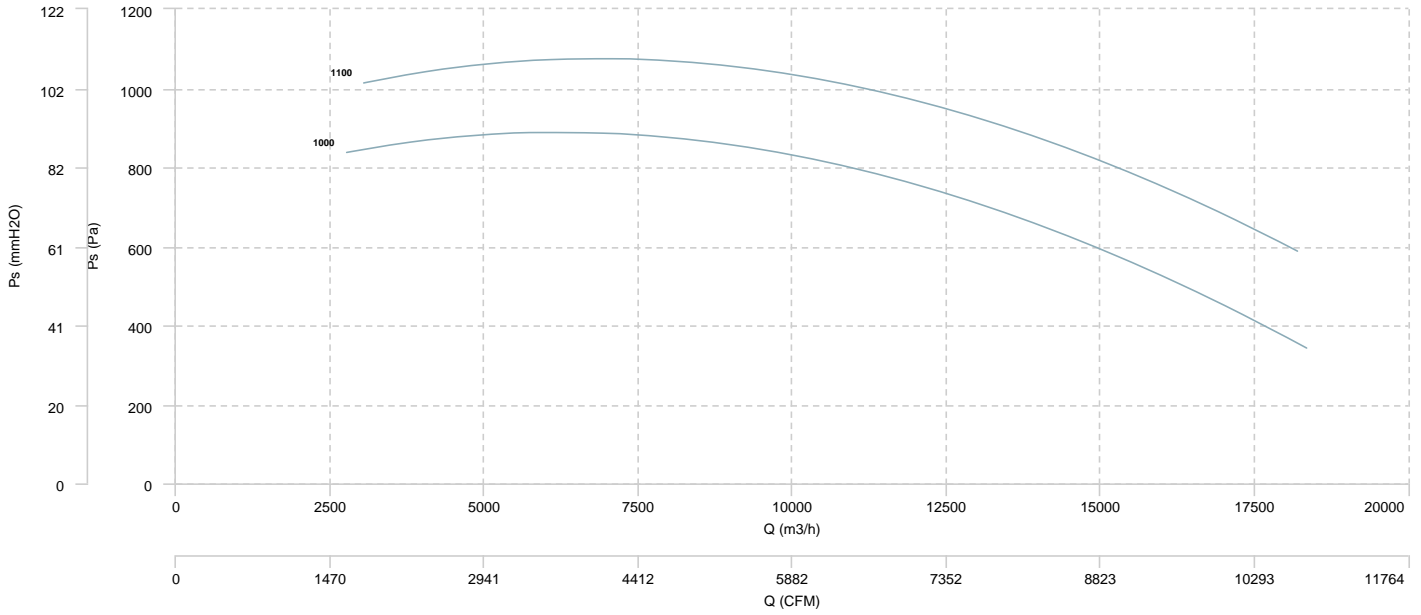

AIR FLOW - ABSORBED POWER

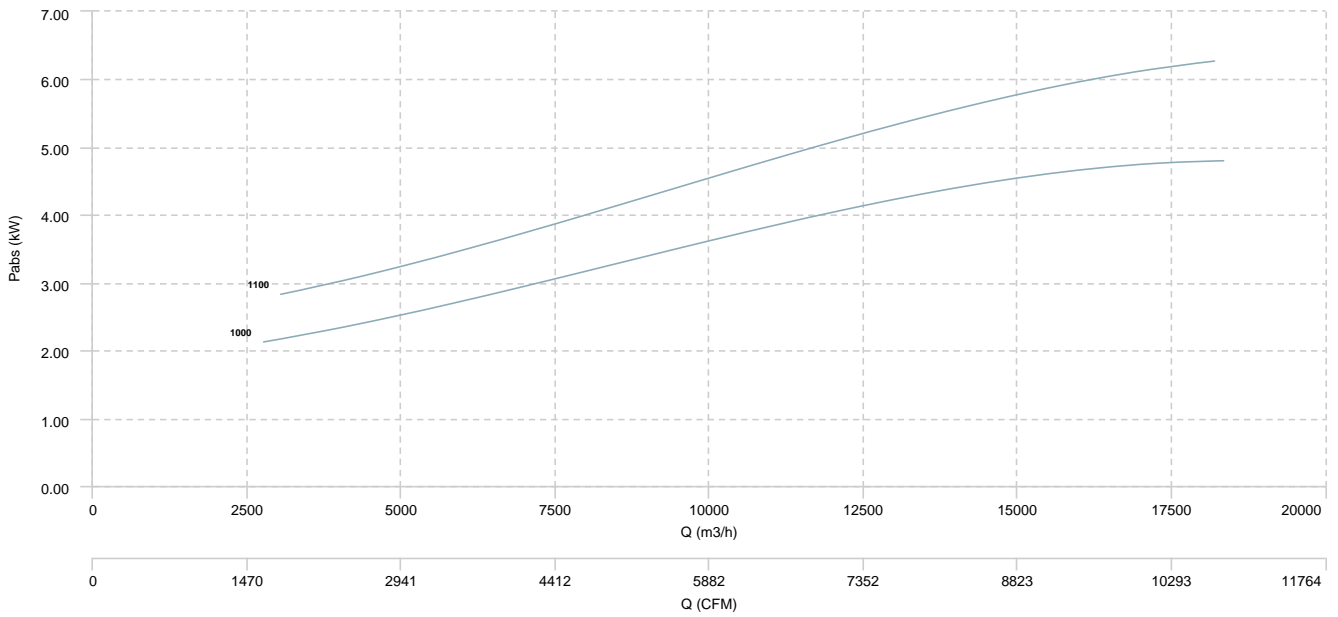

BOX BSTB 710 7,5kW

AIR FLOW - PRESSURE

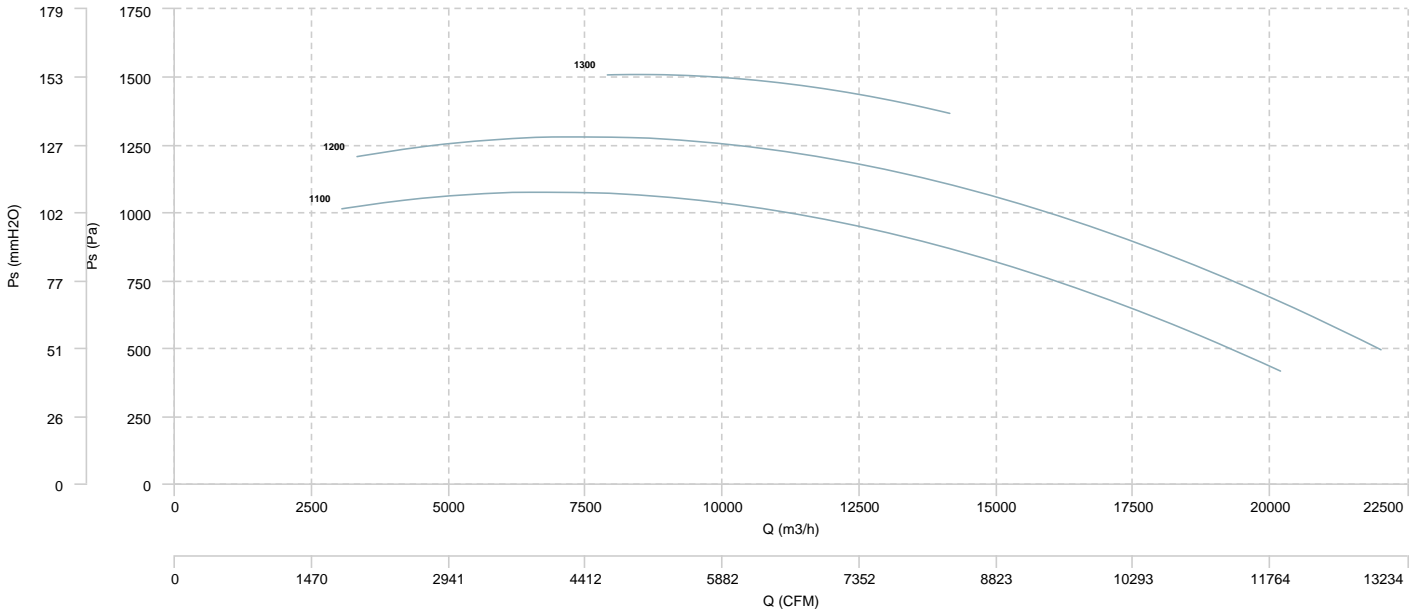

AIR FLOW - ABSORBED POWER

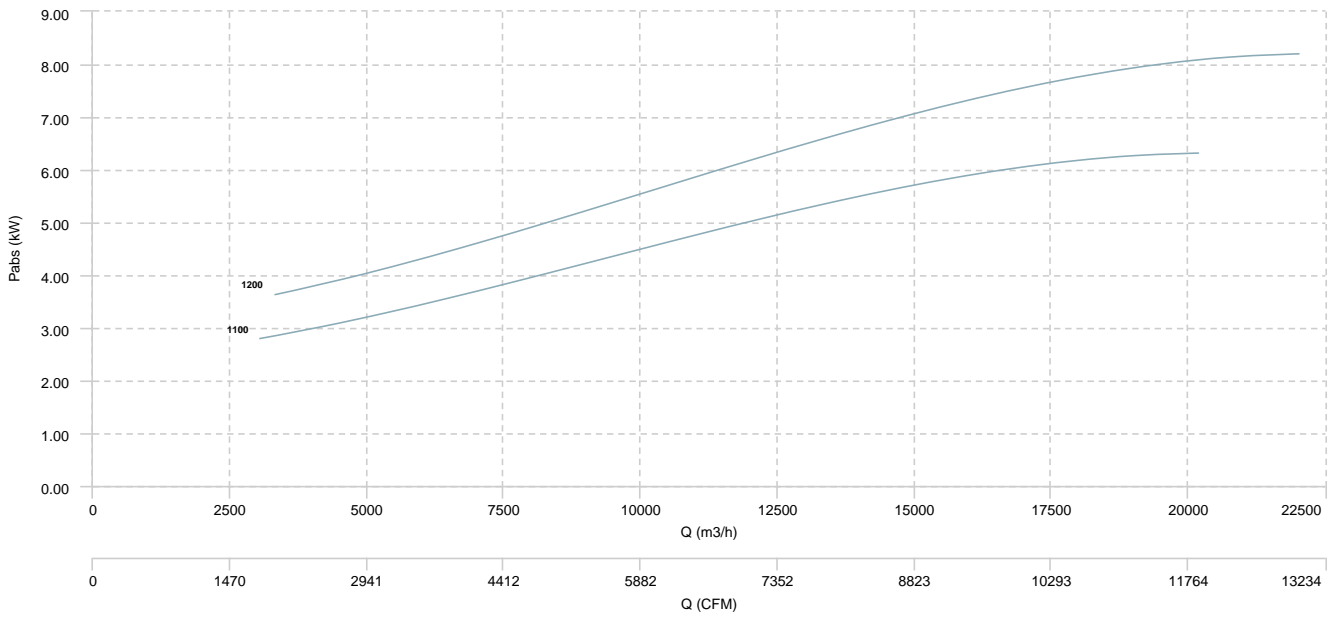

BOX BSTB 710 11kW

AIR FLOW - PRESSURE

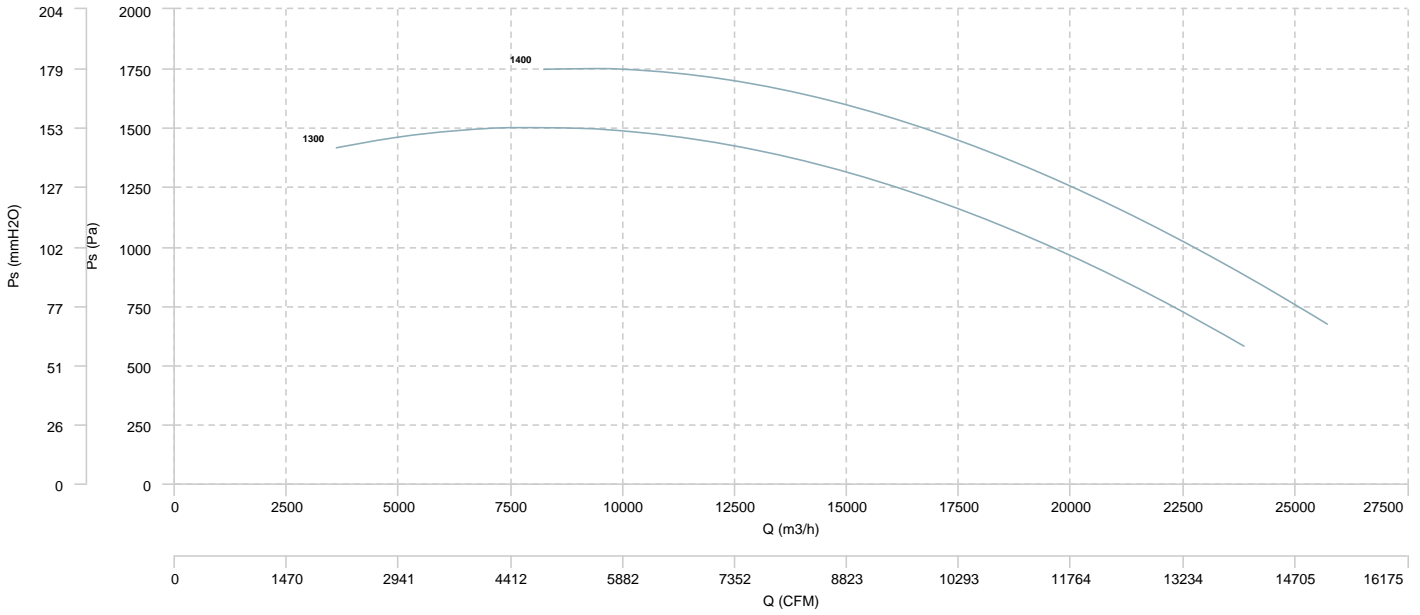

AIR FLOW - ABSORBED POWER

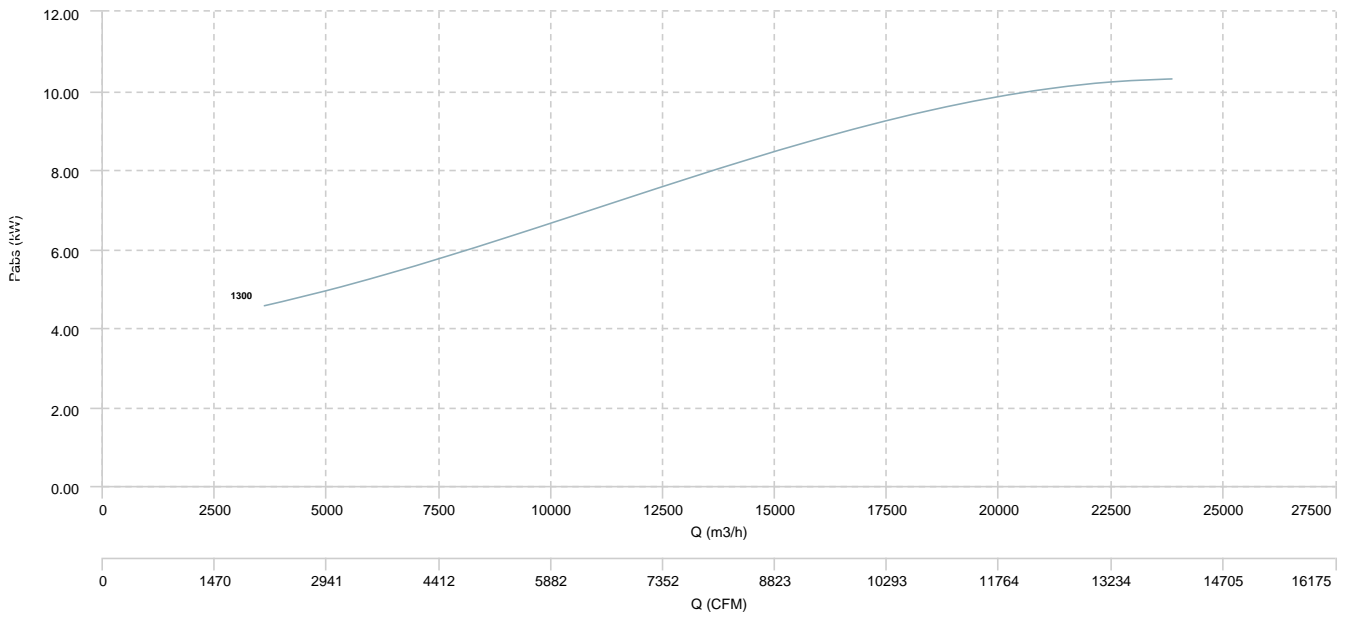

BOX BSTB 710 15kW

AIR FLOW - PRESSURE

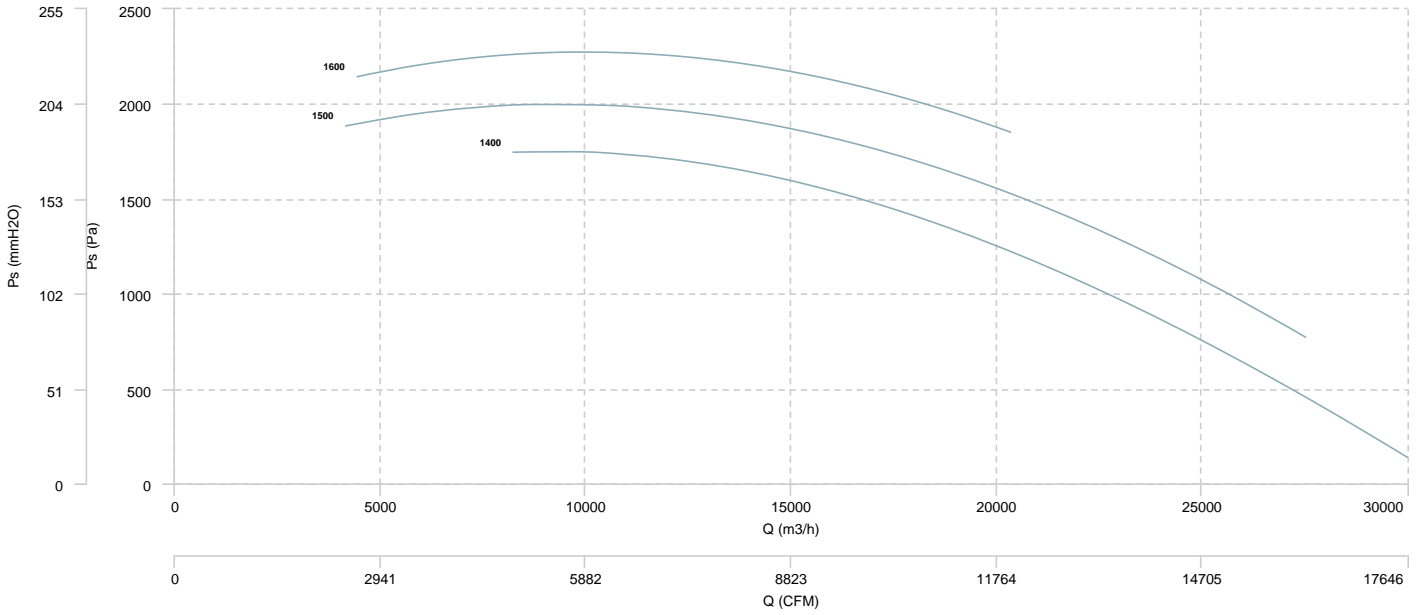

AIR FLOW - ABSORBED POWER

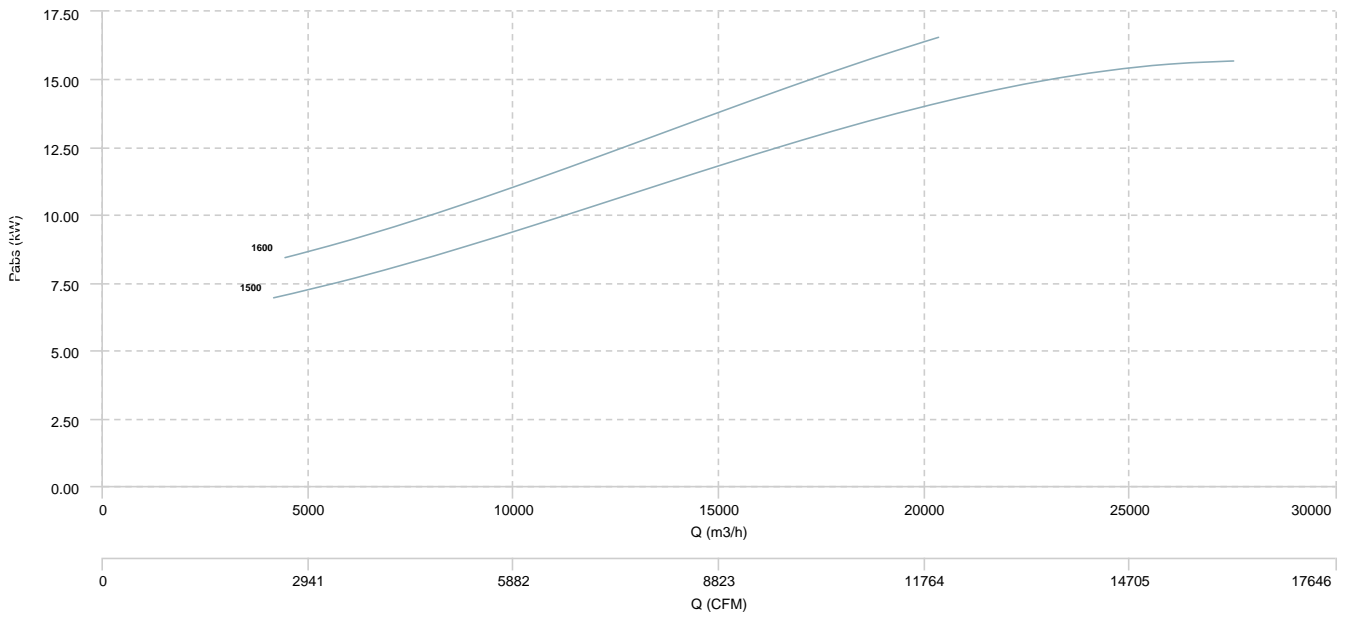

BOX BSTB 710 18,5kW

AIR FLOW - PRESSURE

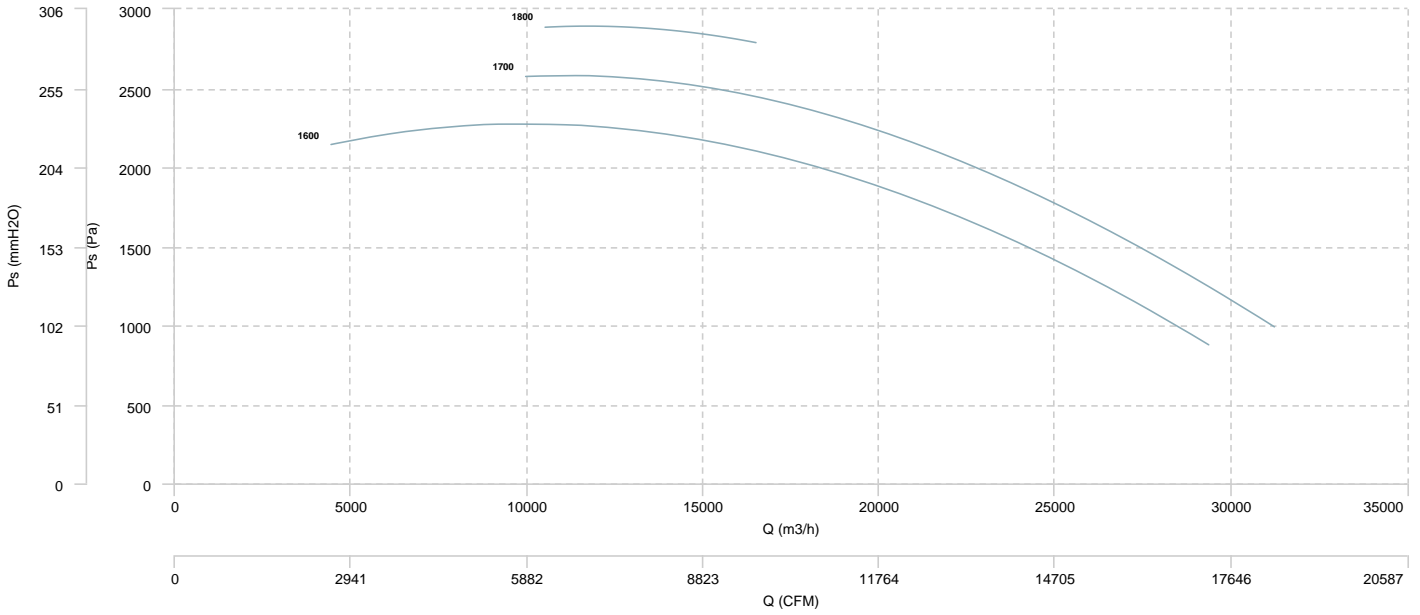

AIR FLOW - ABSORBED POWER

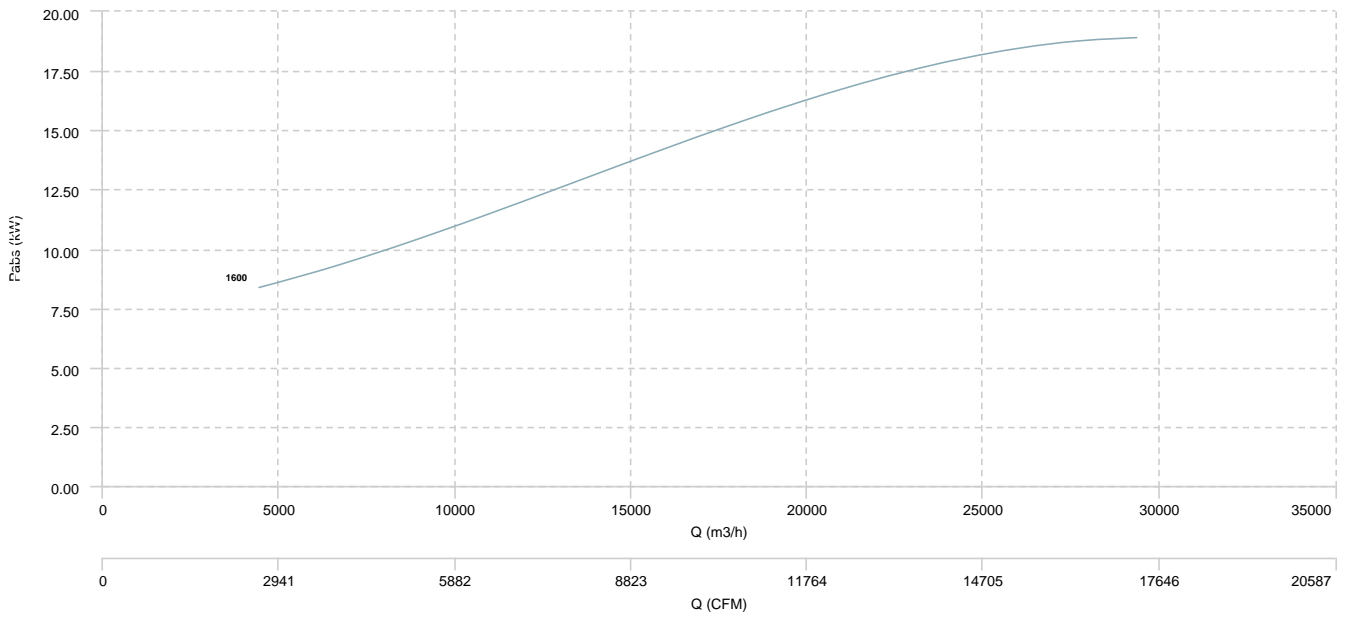

Sound data

Sound / 4 poles

		Sound power Lw dB (A)								
Model		63 Hz	125 Hz	250 Hz	500 Hz	1000 Hz	2000 Hz	4000 Hz	8000 Hz	Total
BOX BSTB 355 0,37kW (1500 RPM)	Inlet	50	61	72	73	73	72	63	52	79
	Radiated	79	79	79	79	79	79	79	79	79
BOX BSTB 355 0,55kW (1500 RPM)	Inlet	50	61	72	73	73	72	63	52	79
	Radiated	79	79	79	79	79	79	79	79	79
BOX BSTB 355 0,75kW (1700 RPM)	Inlet	53	64	75	76	76	75	66	55	81
	Radiated	81	81	81	81	81	81	81	81	81
BOX BSTB 355 1,1kW (1900 RPM)	Inlet	55	66	77	78	78	77	68	57	84
	Radiated	84	84	84	84	84	84	84	84	84
BOX BSTB 355 1,5kW (2100 RPM)	Inlet	57	68	79	80	80	79	70	59	86
	Radiated	86	86	86	86	86	86	86	86	86
BOX BSTB 355 2,2kW (2300 RPM)	Inlet	60	71	82	83	83	82	73	62	88
	Radiated	88	88	88	88	88	88	88	88	88
BOX BSTB 355 3kW (2600 RPM)	Inlet	62	73	84	85	85	84	75	64	91
	Radiated	91	91	91	91	91	91	91	91	91
BOX BSTB 400 0,55kW (1200 RPM)	Inlet	54	62	73	74	77	74	65	53	80
	Radiated	80	80	80	80	80	80	80	80	80
BOX BSTB 400 0,75kW (1400 RPM)	Inlet	57	65	76	77	80	77	68	56	84
	Radiated	84	84	84	84	84	84	84	84	84
BOX BSTB 400 1,1kW (1500 RPM)	Inlet	59	67	78	79	82	79	70	58	86
	Radiated	86	86	86	86	86	86	86	86	86
BOX BSTB 400 1,5kW (1700 RPM)	Inlet	61	69	80	81	84	81	72	60	88
	Radiated	88	88	88	88	88	88	88	88	88
BOX BSTB 400 2,2kW (1900 RPM)	Inlet	64	72	83	84	87	84	75	63	91
	Radiated	91	91	91	91	91	91	91	91	91
BOX BSTB 400 3kW (2100 RPM)	Inlet	66	74	85	86	89	86	77	65	93
	Radiated	93	93	93	93	93	93	93	93	93
BOX BSTB 400 4kW (2400 RPM)	Inlet	69	77	88	89	92	89	80	68	96
	Radiated	96	96	96	96	96	96	96	96	96
BOX BSTB 450 0,75kW (1200 RPM)	Inlet	57	69	79	80	81	78	69	56	85
	Radiated	85	85	85	85	85	85	85	85	85
BOX BSTB 450 1,1kW (1200 RPM)	Inlet	57	69	79	80	81	78	69	56	85
	Radiated	85	85	85	85	85	85	85	85	85
BOX BSTB 450 1,5kW (1400 RPM)	Inlet	60	72	82	83	84	81	72	59	89
	Radiated	89	89	89	89	89	89	89	89	89
BOX BSTB 450 2,2kW (1600 RPM)	Inlet	63	75	85	86	87	84	75	62	92
	Radiated	92	92	92	92	92	92	92	92	92

		Sound power Lw dB (A)								
Model		63 Hz	125 Hz	250 Hz	500 Hz	1000 Hz	2000 Hz	4000 Hz	8000 Hz	Total
BOX BSTB 450 3kW (1800 RPM)	Inlet	66	78	88	89	90	87	78	65	95
	Radiated	95	95	95	95	95	95	95	95	95
BOX BSTB 450 4kW (2000 RPM)	Inlet	68	80	90	91	92	89	80	67	97
	Radiated	97	97	97	97	97	97	97	97	97
BOX BSTB 450 5,5kW (2100 RPM)	Inlet	69	81	91	92	93	90	81	68	98
	Radiated	98	98	98	98	98	98	98	98	98
BOX BSTB 450 7,5kW (2400 RPM)	Inlet	72	84	94	95	96	93	84	71	101
	Radiated	101	101	101	101	101	101	101	101	101
BOX BSTB 500 1,1kW (900 RPM)	Inlet	48	64	71	73	76	72	65	51	80
	Radiated	80	80	80	80	80	80	80	80	80
BOX BSTB 500 1,5kW (1200 RPM)	Inlet	55	71	78	80	83	79	72	58	87
	Radiated	87	87	87	87	87	87	87	87	87
BOX BSTB 500 2,2kW (1300 RPM)	Inlet	57	73	80	82	85	81	74	60	89
	Radiated	89	89	89	89	89	89	89	89	89
BOX BSTB 500 3kW (1500 RPM)	Inlet	60	76	83	85	88	84	77	63	92
	Radiated	92	92	92	92	92	92	92	92	92
BOX BSTB 500 4kW (1700 RPM)	Inlet	63	79	86	88	91	87	80	66	95
	Radiated	95	95	95	95	95	95	95	95	95
BOX BSTB 500 5,5kW (1800 RPM)	Inlet	64	80	87	89	92	88	81	67	96
	Radiated	96	96	96	96	96	96	96	96	96
BOX BSTB 500 7,5kW (2000 RPM)	Inlet	67	83	90	92	95	91	84	70	98
	Radiated	98	98	98	98	98	98	98	98	98
BOX BSTB 560 1,5kW (800 RPM)	Inlet	49	67	73	75	79	74	67	54	82
	Radiated	82	82	82	82	82	82	82	82	82
BOX BSTB 560 2,2kW (1200 RPM)	Inlet	58	76	82	84	88	83	76	63	91
	Radiated	91	91	91	91	91	91	91	91	91
BOX BSTB 560 3kW (1300 RPM)	Inlet	60	78	84	86	90	85	78	65	93
	Radiated	93	93	93	93	93	93	93	93	93
BOX BSTB 560 4kW (1500 RPM)	Inlet	63	81	87	89	93	88	81	68	96
	Radiated	96	96	96	96	96	96	96	96	96
BOX BSTB 560 5,5kW (1600 RPM)	Inlet	64	82	88	90	94	89	82	69	98
	Radiated	98	98	98	98	98	98	98	98	98
BOX BSTB 560 7,5kW (1800 RPM)	Inlet	67	85	91	93	97	92	85	72	100
	Radiated	100	100	100	100	100	100	100	100	100
BOX BSTB 560 11kW (2000 RPM)	Inlet	69	87	93	95	99	94	87	74	103
	Radiated	103	103	103	103	103	103	103	103	103
BOX BSTB 630 2,2kW (800 RPM)	Inlet	51	68	75	77	81	77	69	57	84
	Radiated	84	84	84	84	84	84	84	84	84

		Sound power Lw dB (A)								
Model		63 Hz	125 Hz	250 Hz	500 Hz	1000 Hz	2000 Hz	4000 Hz	8000 Hz	Total
BOX BSTB 630 3kW (1000 RPM)	Inlet	56	73	80	82	86	82	74	62	89
	Radiated	89	89	89	89	89	89	89	89	89
BOX BSTB 630 4kW (1100 RPM)	Inlet	58	75	82	84	88	84	76	64	92
	Radiated	92	92	92	92	92	92	92	92	92
BOX BSTB 630 5,5kW (1200 RPM)	Inlet	60	77	84	86	90	86	78	66	94
	Radiated	94	94	94	94	94	94	94	94	94
BOX BSTB 630 7,5kW (1400 RPM)	Inlet	64	81	88	90	94	90	82	70	97
	Radiated	97	97	97	97	97	97	97	97	97
BOX BSTB 630 11kW (1500 RPM)	Inlet	65	82	89	91	95	91	83	71	99
	Radiated	99	99	99	99	99	99	99	99	99
BOX BSTB 630 15kW (1700 RPM)	Inlet	68	85	92	94	98	94	86	74	102
	Radiated	102	102	102	102	102	102	102	102	102
BOX BSTB 710 3kW (600 RPM)	Inlet	46	63	70	73	76	71	64	49	80
	Radiated	80	80	80	80	80	80	80	80	80
BOX BSTB 710 4kW (900 RPM)	Inlet	56	73	80	83	86	81	74	59	89
	Radiated	89	89	89	89	89	89	89	89	89
BOX BSTB 710 5,5kW (1000 RPM)	Inlet	58	75	82	85	88	83	76	61	91
	Radiated	91	91	91	91	91	91	91	91	91
BOX BSTB 710 7,5kW (1100 RPM)	Inlet	60	77	84	87	90	85	78	63	94
	Radiated	94	94	94	94	94	94	94	94	94
BOX BSTB 710 11kW (1300 RPM)	Inlet	64	81	88	91	94	89	82	67	97
	Radiated	97	97	97	97	97	97	97	97	97
BOX BSTB 710 15kW (1500 RPM)	Inlet	67	84	91	94	97	92	85	70	101
	Radiated	101	101	101	101	101	101	101	101	101
BOX BSTB 710 18,5kW (1600 RPM)	Inlet	69	86	93	96	99	94	87	72	102
	Radiated	102	102	102	102	102	102	102	102	102

Notes:

* To calculate the sound power level at different rpm from those indicated above, use the following formula:

$$Lw \text{ dB(A)}_{rpmA} = Lw \text{ dB(A)}_{rpmB} + 52.5 \cdot \log_{10} \frac{rpmA}{rpmB}$$

erp data

ERP	
Fan type	Centrifugal fan backward blades with casing
Installation category	A
Efficiency category	Static
The fan has to be installed with FSC	No

ERP / 4 poles

Model	Motor power (kW)	Maximum efficiency point data						
		Max. efficiency (%)	Efficiency grade (N) (N)	Air Flow (m3/h)	Ps (Pa)	Pabs (kW)	speed (rpm)	Specific ratio
BOX BSTB 355 0,37kW	0,37	47,56	61,27	2.187,86	417,76	0,49	1500	1,00
BOX BSTB 355 0,75kW	0,75	52,58	65,04	2.479,57	536,59	0,65	1700	1,00
BOX BSTB 355 0,75kW	0,75	52,58	63,52	2.771,29	670,27	0,91	1900	1,00
BOX BSTB 355 1,1kW	1,1	53,77	64,81	2.771,29	670,27	0,89	1900	1,00
BOX BSTB 355 1,1kW	1,1	53,77	64,11	2.917,15	742,68	1,04	2000	1,00
BOX BSTB 355 1,1kW	1,1	53,77	63,44	3.063	818,80	1,20	2100	1,00
BOX BSTB 355 2,2kW	2,2	55,69	64,27	3.354,72	982,19	1,52	2300	1,00
BOX BSTB 355 2,2kW	2,2	55,69	63,69	3.500,57	1.069,46	1,73	2400	1,00
BOX BSTB 355 2,2kW	2,2	55,69	62,59	3.792,29	1.255,13	2,20	2600	1,00
BOX BSTB 400 0,55kW	0,55	47,94	62,07	2.594,45	336,53	0,45	1200	1,00
BOX BSTB 400 0,55kW	0,55	47,94	60,98	2.810,65	394,96	0,57	1300	1,00
BOX BSTB 400 0,55kW	0,55	47,94	59,97	3.026,85	458,06	0,72	1400	1,00
BOX BSTB 400 0,75kW	0,75	52,28	64,70	3.026,85	458,06	0,66	1400	1,00
BOX BSTB 400 0,75kW	0,75	52,28	63,75	3.243,06	525,83	0,81	1500	1,00
BOX BSTB 400 1,1kW	1,1	53,46	65,04	3.243,06	525,83	0,79	1500	1,00
BOX BSTB 400 1,1kW	1,1	53,46	64,15	3.459,26	598,28	0,96	1600	1,00
BOX BSTB 400 1,1kW	1,1	53,46	63,32	3.675,47	675,40	1,15	1700	1,00
BOX BSTB 400 3kW	3	56,15	63,35	4.540,27	1.030,63	2,06	2100	1,00
BOX BSTB 400 3kW	3	56,15	62,71	4.756,48	1.131,12	2,37	2200	1,00
BOX BSTB 400 3kW	3	56,15	62,11	4.972,69	1.236,28	2,71	2300	1,00
BOX BSTB 400 3kW	3	56,15	61,52	5.188,90	1.346,12	3,08	2400	1,00
BOX BSTB 400 4kW	4	56,88	62,30	5.188,89	1.346,12	3,04	2400	1,00
BOX BSTB 400 4kW	4	56,88	61,75	5.405,11	1.460,64	3,44	2500	1,00
BOX BSTB 400 4kW	4	56,88	61,21	5.621,31	1.579,82	3,87	2600	1,00
BOX BSTB 400 4kW	4	56,61	60,13	5.600	1.919,06	4,62	2800	1,00
BOX BSTB 400 4kW	4	54,55	58,08	4.810	2.205,38	4,62	2900	1,00
BOX BSTB 400 4kW	4	51,61	55,14	4.110	2.434,28	4,61	3000	1,00
BOX BSTB 400 4kW	4	48,50	52,03	3.470	2.619,18	4,62	3100	1,00

Model	Motor power (kW)	Maximum efficiency point data						
		Max. efficiency (%)	Efficiency grade (N) (N)	Air Flow (m3/h)	Ps (Pa)	Pabs (kW)	speed (rpm)	Specific ratio
BOX BSTB 400 4kW	4	45,47	49	2.860	2.766,88	4,61	3200	1,00
BOX BSTB 450 0,75kW	0,75	52,49	64,76	3.384,76	439,83	0,68	1200	1,00
BOX BSTB 450 1,1kW	1,1	53,67	66,05	3.384,76	439,83	0,66	1200	1,00
BOX BSTB 450 1,1kW	1,1	53,67	63,94	3.948,89	598,66	1,05	1400	1,00
BOX BSTB 450 1,5kW	1,5	54,60	64,94	3.948,88	598,66	1,04	1400	1,00
BOX BSTB 450 1,5kW	1,5	54,60	64	4.230,95	687,23	1,27	1500	1,00
BOX BSTB 450 1,5kW	1,5	54,60	63,11	4.513,01	781,92	1,55	1600	1,00
BOX BSTB 450 2,2kW	2,2	55,58	64,18	4.513,01	781,92	1,52	1600	1,00
BOX BSTB 450 2,2kW	2,2	55,59	63,35	4.795,08	882,71	1,82	1700	1,00
BOX BSTB 450 2,2kW	2,2	55,59	62,57	5.077,14	989,61	2,16	1800	1,00
BOX BSTB 450 3kW	3	56,38	63,43	5.077,14	989,61	2,13	1800	1,00
BOX BSTB 450 3kW	3	56,38	62,69	5.359,19	1.102,63	2,51	1900	1,00
BOX BSTB 450 3kW	3	56,38	61,99	5.641,27	1.221,75	2,92	2000	1,00
BOX BSTB 450 4kW	4	57,10	62,77	5.641,28	1.221,74	2,89	2000	1,00
BOX BSTB 450 4kW	4	57,10	62,10	5.923,34	1.346,97	3,34	2100	1,00
BOX BSTB 450 5,5kW	5,5	57,83	62,89	5.923,34	1.346,97	3,30	2100	1,00
BOX BSTB 450 5,5kW	5,5	57,83	62,25	6.205,36	1.478,32	3,79	2200	1,00
BOX BSTB 450 5,5kW	5,5	57,83	61,64	6.487,43	1.615,76	4,33	2300	1,00
BOX BSTB 450 5,5kW	5,5	57,83	61,06	6.769,49	1.759,32	4,92	2400	1,00
BOX BSTB 450 7,5kW	7,5	58,49	61,77	6.769,52	1.759,31	4,87	2400	1,00
BOX BSTB 450 7,5kW	7,5	58,49	61,21	7.051,61	1.908,97	5,50	2500	1,00
BOX BSTB 450 7,5kW	7,5	58,49	60,67	7.333,61	2.064,76	6,19	2600	1,00
BOX BSTB 450 7,5kW	7,5	58,49	59,66	7.897,75	2.394,63	7,73	2800	1,00
BOX BSTB 450 7,5kW	7,5	58,44	59,21	7.930	2.613,41	8,45	2900	1,00
BOX BSTB 500 1,1kW	1,1	52,75	65,80	4.534,95	232,03	0,57	900	1,00
BOX BSTB 500 1,1kW	1,1	52,75	65,46	3.401,22	402,02	0,62	1000	1,00
BOX BSTB 500 1,1kW	1,1	52,75	62,92	4.157,05	574,69	1,07	1200	1,00
BOX BSTB 500 7,5kW	7,5	57,48	60,81	7.558,28	1.529,75	4,81	2000	1,00
BOX BSTB 500 7,5kW	7,5	57,48	60,15	7.936,17	1.686,55	5,57	2100	1,00
BOX BSTB 500 7,5kW	7,5	57,48	58,32	9.069,90	2.202,84	8,31	2400	1,00
BOX BSTB 500 7,5kW	7,5	56,21	56,98	7.880	2.576,17	8,45	2500	1,00
BOX BSTB 500 7,5kW	7,5	52,05	52,82	6.430	2.891,19	8,45	2600	1,00
BOX BSTB 560 1,5kW	1,5	52,83	65,64	5.140,27	207,22	0,60	800	1,00
BOX BSTB 560 1,5kW	1,5	52,83	64,06	5.607,58	276,38	0,85	900	1,00
BOX BSTB 560 1,5kW	1,5	52,83	63,17	3.738,38	529,26	1,04	1000	1,00
BOX BSTB 560 1,5kW	1,5	52,83	61,84	4.205,68	635,75	1,39	1100	1,00
BOX BSTB 560 1,5kW	1,5	52,83	60,63	4.670	751,85	1,81	1200	1,00
BOX BSTB 560 2,2kW	2,2	53,79	61,46	5.607,56	681,87	1,86	1200	1,00



Model	Motor power (kW)	Maximum efficiency point data						
		Max. efficiency (%)	Efficiency grade (N) (N)	Air Flow (m3/h)	Ps (Pa)	Pabs (kW)	speed (rpm)	Specific ratio
BOX BSTB 560 2,2kW	2,2	53,79	60,36	6.074,87	800,24	2,37	1300	1,00
BOX BSTB 560 3kW	3	54,56	61,19	6.074,89	800,24	2,33	1300	1,00
BOX BSTB 560 3kW	3	54,19	58,97	6.410	1.126,56	3,51	1500	1,00
BOX BSTB 560 4kW	4	55,26	60	7.009,47	1.065,41	3,54	1500	1,00
BOX BSTB 560 4kW	4	55,26	59,11	7.476,72	1.212,21	4,30	1600	1,00
BOX BSTB 560 7,5kW	7,5	56,60	58,95	8.411,38	1.534,19	5,97	1800	1,00
BOX BSTB 560 7,5kW	7,5	56,60	58,21	8.878,68	1.709,39	7,02	1900	1,00
BOX BSTB 560 7,5kW	7,5	56,60	57,51	9.345,86	1.894,08	8,19	2000	1,00
BOX BSTB 560 11kW	11	57,30	58,27	9.346,06	1.894,06	8,09	2000	1,00
BOX BSTB 560 11kW	11	57,30	57,60	9.813,17	2.088,23	9,37	2100	1,00
BOX BSTB 560 11kW	11	57,30	57,29	10.280,70	2.291,80	10,77	2200	1,00
BOX BSTB 630 3kW	3	57,38	65,09	7.164,72	621,62	1,85	1000	1,00
BOX BSTB 630 3kW	3	57,38	63,78	7.881,29	752,16	2,46	1100	1,00
BOX BSTB 630 4kW	4	58,12	64,58	7.881,24	752,16	2,43	1100	1,00
BOX BSTB 630 4kW	4	58,12	63,39	8.597,66	895,13	3,15	1200	1,00
BOX BSTB 630 7,5kW	7,5	59,53	62,80	10.030,65	1.218,37	4,88	1400	1,00
BOX BSTB 630 7,5kW	7,5	59,53	61,85	10.747,22	1.398,64	6	1500	1,00
BOX BSTB 630 15kW	15	60,80	61,51	12.179,92	1.796,49	8,56	1700	1,00
BOX BSTB 630 15kW	15	60,80	60,67	13.612,96	2.244,05	11,95	1900	1,00
BOX BSTB 710 3kW	3	56,71	67,83	6.912,80	279,82	0,87	600	1,00
BOX BSTB 710 3kW	3	56,71	65,72	8.064,91	380,87	1,39	700	1,00
BOX BSTB 710 3kW	3	56,71	63,89	9.217,12	497,46	2,07	800	1,00
BOX BSTB 710 3kW	3	56,71	62,28	10.369,31	629,60	2,95	900	1,00
BOX BSTB 710 5,5kW	5,5	58,17	62,41	11.521,50	777,28	3,94	1000	1,00
BOX BSTB 710 5,5kW	5,5	58,17	61,11	12.673,48	940,52	5,25	1100	1,00
BOX BSTB 710 15kW	15	60,09	59,88	17.281,66	1.748,91	12,88	1500	1,00
BOX BSTB 710 15kW	15	60,09	59,67	18.435,59	1.989,76	15,63	1600	1,00