

INT 3V



SPEED SELECTOR SWITCH

4 steps (0-1-2-3) start-stop switch selector, for speeds regulation of BD 3V range.

Fans



BD3V



CHELYS

Technical data

Code	Model	Max.I. (A)	Weight	Connect. diagram
960000603	INT 3V 3A	3	0,16	1
960000620	INT 3V 20A	20	-	2

Dimensions

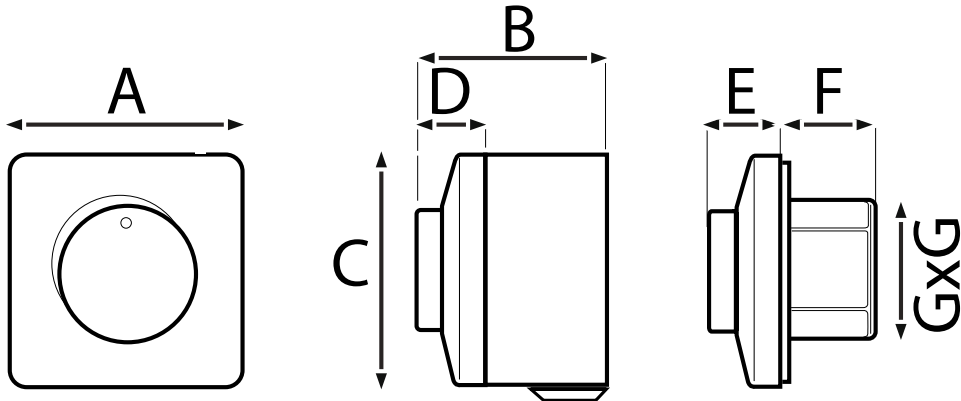

Model	A	B	C	D	E	F	G
INT 3V 3A	82	65	82	24	24	32	50x50

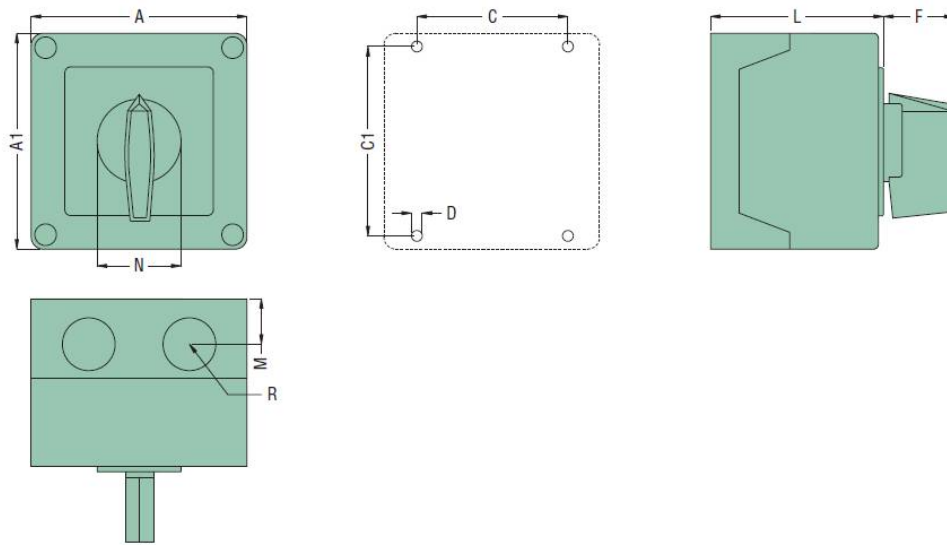

Model	A	A1	C	C1	D	F	L	M	N
INT 3V 20A	75	75	64	50	4,5	19	57,5	14	28

Model	R
INT 3V 20A	4xPG 13,5

Wiring diagram

DIAGRAM N° 1

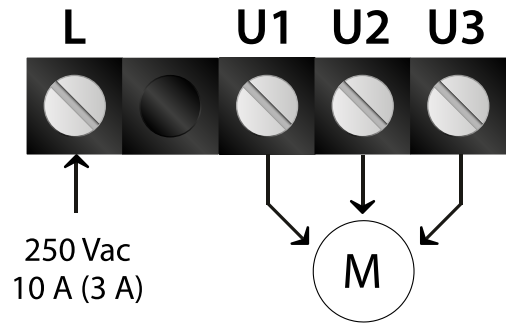
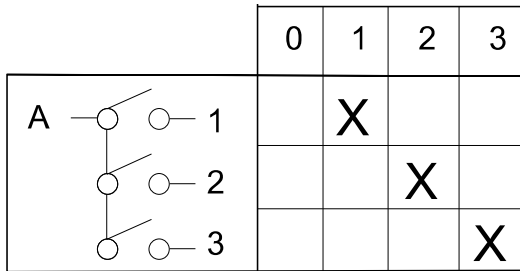

DIAGRAM N° 2

