

MA26-31



FORWARD ALLUMINIUM IMPELLER FAN, ALLUMINIUM CAST CASING

MANUFACTURING FEATURES:

- Cast aluminium housing.
- Cast aluminium impeller.
- Epoxy powder finishing coat.
- Standard asynchronous squirrel-cage motor with IP-55 protection and Class F insulation. Manufactured with standard voltages: 230V 50Hz in single phase motors and 230/400V 50Hz in three phase motors.
- Standard position LG 270.

APPLICATIONS:

Designed for inline installation, they are suitable for:

- Industrial applications, extraction or injection of air.
- Cooling of machines and parts.
- Clean and slightly dusty air transport.
- Maximum working temperature: carried air: 130°C, ambient: 60°C.

UNDER REQUEST:

- 60Hz fans and special voltages.
- Position: LG 0, LG 45, LG 90, LG 135, LG 180, LG315.

Accessories



AC



FILTRO
EMC



INT



JE-45



RA



RBS



SFC

Technical data

Single-phase motor

Code	Model	R.P.M.	Rated I. (A) 230V	Rated power kW	Max. Airflow m3/h	Sound db (A)*	Weight	Connect. diagram
253300104	MA 26 M2 0,37kW	2800	2,61	0,37	750	63	13	1

Three-phase motor

Code	Model	R.P.M.	Rated I. (A) 400V	Rated power kW	Max. Airflow m3/h	Sound db (A)*	Weight	Connect. diagram
253300106	MA 26 T2 0,37kW	2800	0,91	0,37	750	63	13	2
253330106	MA 27 T2 0,55kW	2800	1,29	0,55	860	66	14	2
253390106	MA 28 T2 1,1kW	2800	2,33	1,10	1.450	68	20	2
253430106	MA 31 T2 2,2kW	2800	4,58	2,20	2.170	72	30	2

Notes:

* Total sound pressure level at the point of maximum flow measured in dB(A) in the suction measured in free field at a distance of 6m from the source

Dimensions

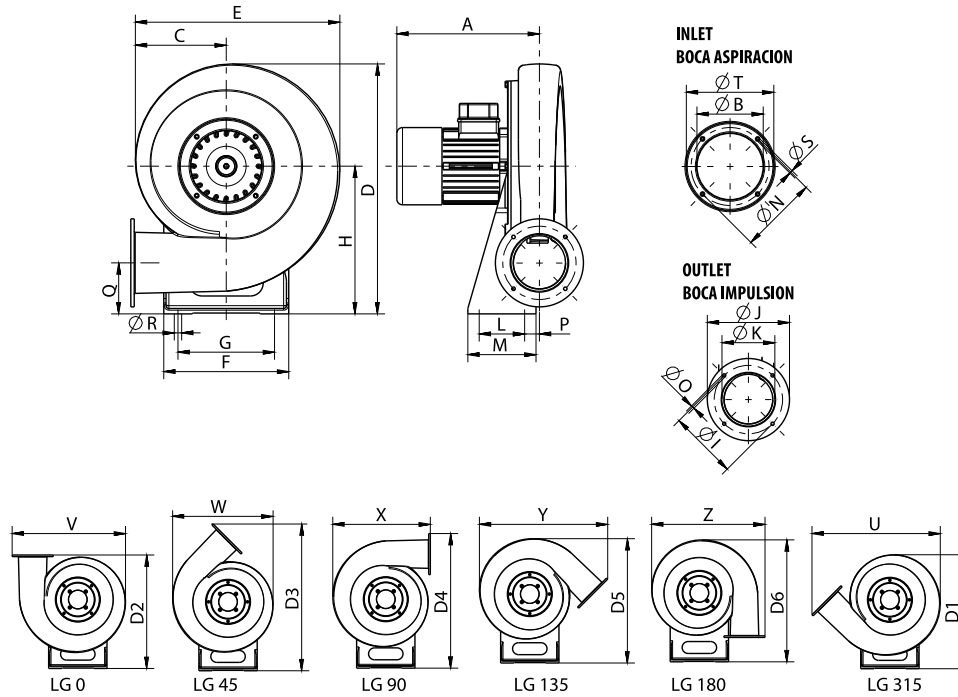

Model	A	BØ	C	D	D1	D2	D3	D4	D5
MA 26 M2 0,37kW	240	110	162	413	405	402	519	473	440
MA 26 T2 0,37kW	240	110	162	413	405	402	519	473	440
MA 27 T2 0,55kW	250	125	168	440	431	428	552	505	470
MA 28 T2 1,1kW	275	125	168	440	470	468	605	558	516
MA 31 T2 2,2kW	320	160	193	530	518	513	668	620	568

Model	D6	E	F	G	H	I	J	K	L
MA 26 M2 0,37kW	431	353	210	160	240	119	140	90	65
MA 26 T2 0,37kW	431	353	210	160	240	119	140	90	65
MA 27 T2 0,55kW	460	368	220	170	260	129	155	100	80
MA 28 T2 1,1kW	505	393	230	180	290	160	182	130	100
MA 31 T2 2,2kW	555	428	240	190	323	175	200	140	120

Model	M	NØ	OØ	P	Q	RØ	SØ	TØ	U
MA 26 M2 0,37kW	105	132	6,2	18,5	77	13	M6	152	460
MA 26 T2 0,37kW	105	132	6,2	18,5	77	13	M6	152	460
MA 27 T2 0,55kW	120	147	6,2	26	90	13	M6	165	482
MA 28 T2 1,1kW	140	162	10,2	20	113	13	M6	187	518
MA 31 T2 2,2kW	160	180	10,2	18,5	122	13	M6	215	570

Model	V	W	X	Y	Z
MA 26 M2 0,37kW	406	363	353	460	406
MA 26 T2 0,37kW	406	363	353	460	406
MA 27 T2 0,55kW	425	381	168	482	425
MA 28 T2 1,1kW	460	406	393	518	460
MA 31 T2 2,2kW	510	445	428	570	510

Wiring diagram

DIAGRAM Nº 1

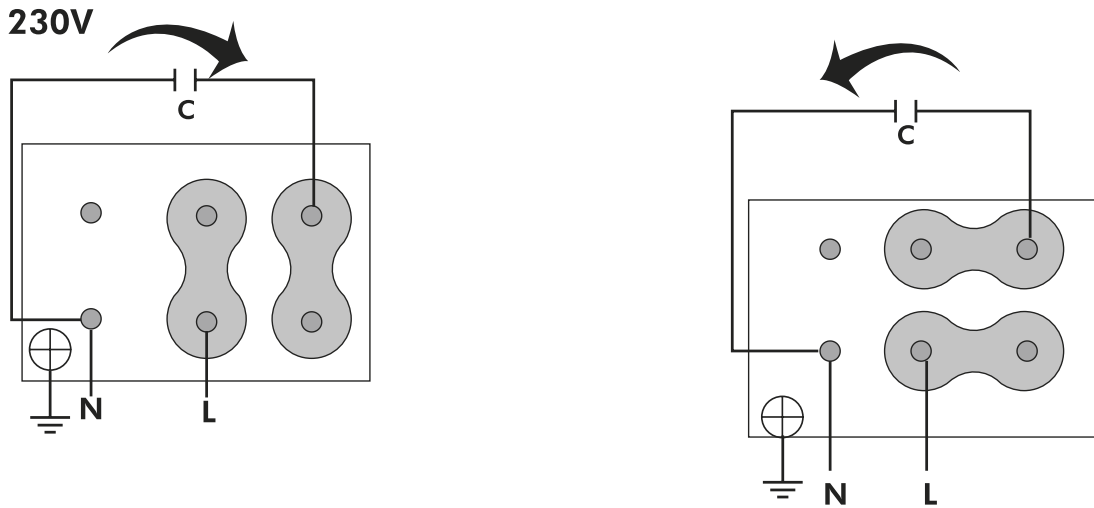
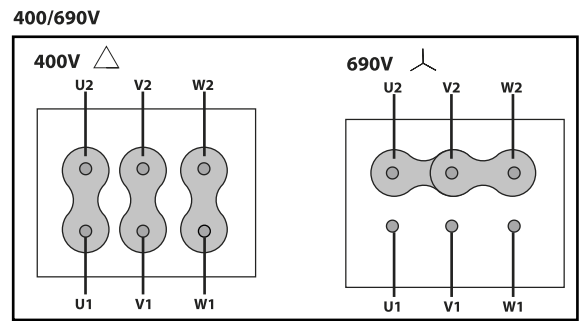
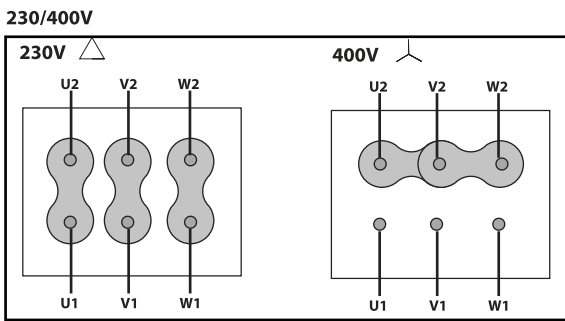

DIAGRAM Nº 2



CHARACTERISCTIC CURVE

1 MA 26 M2 0,37kW

AIR FLOW - PRESSURE

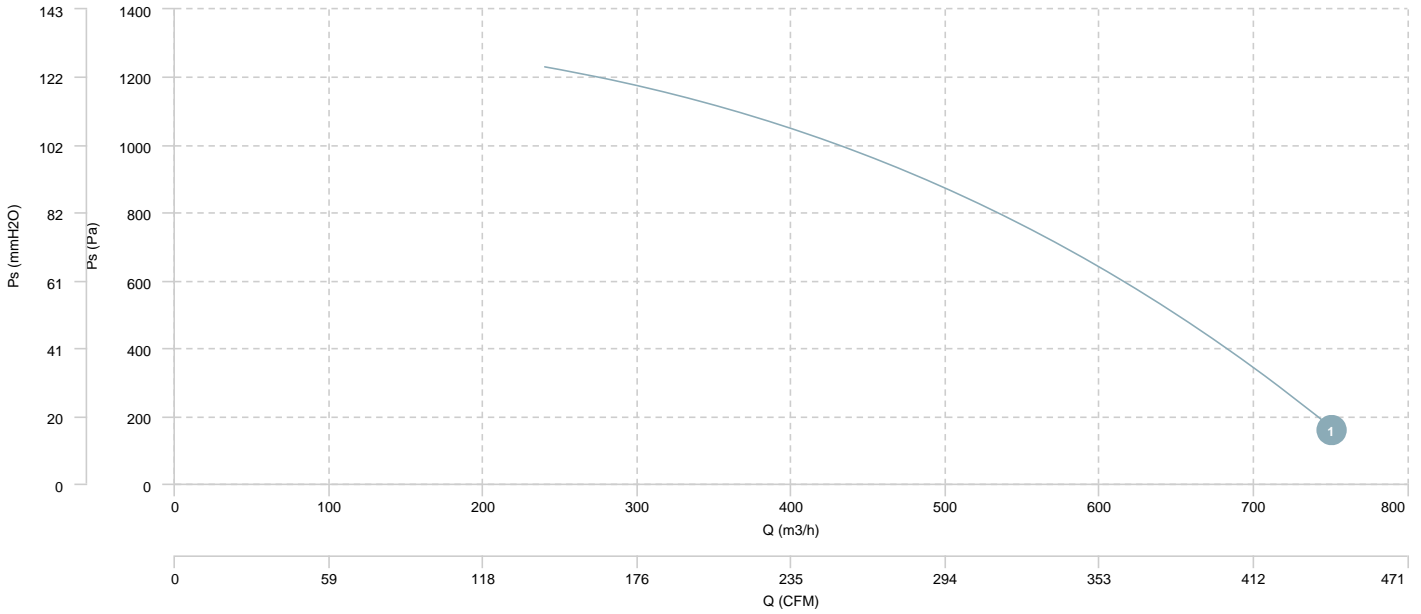

AIR FLOW - ABSORBED POWER

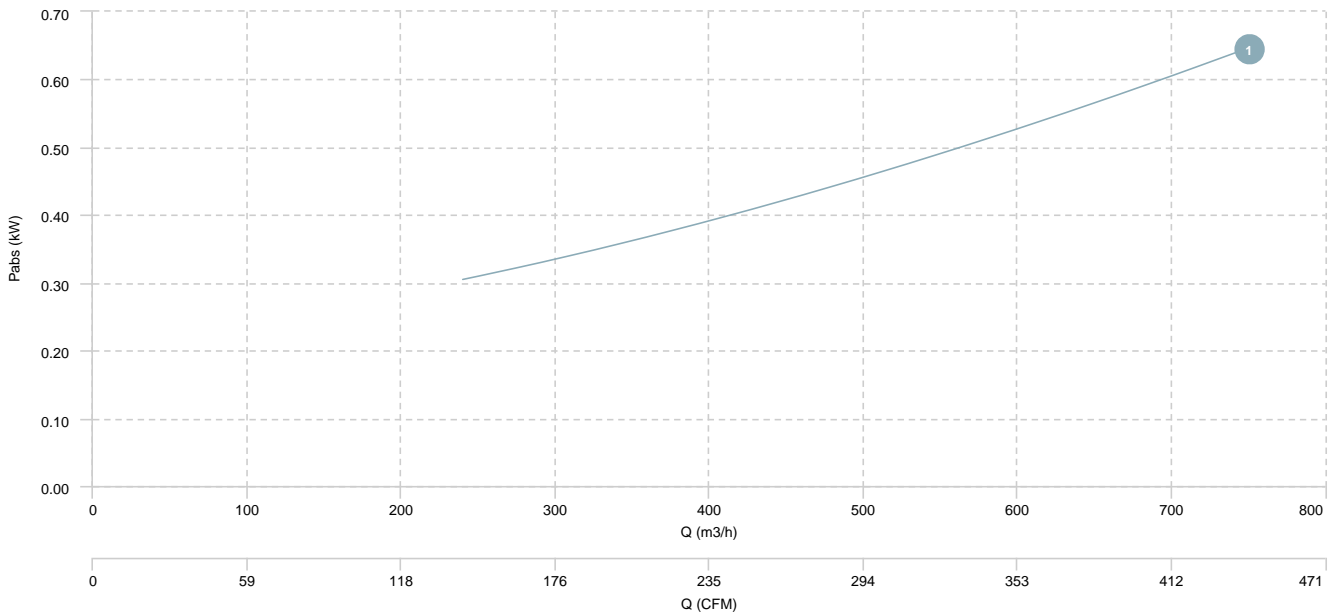

1 MA 26 T2 0,37kW

2 MA 27 T2 0,55kW

3 MA 28 T2 1,1kW

4 MA 31 T2 2,2kW

AIR FLOW - PRESSURE

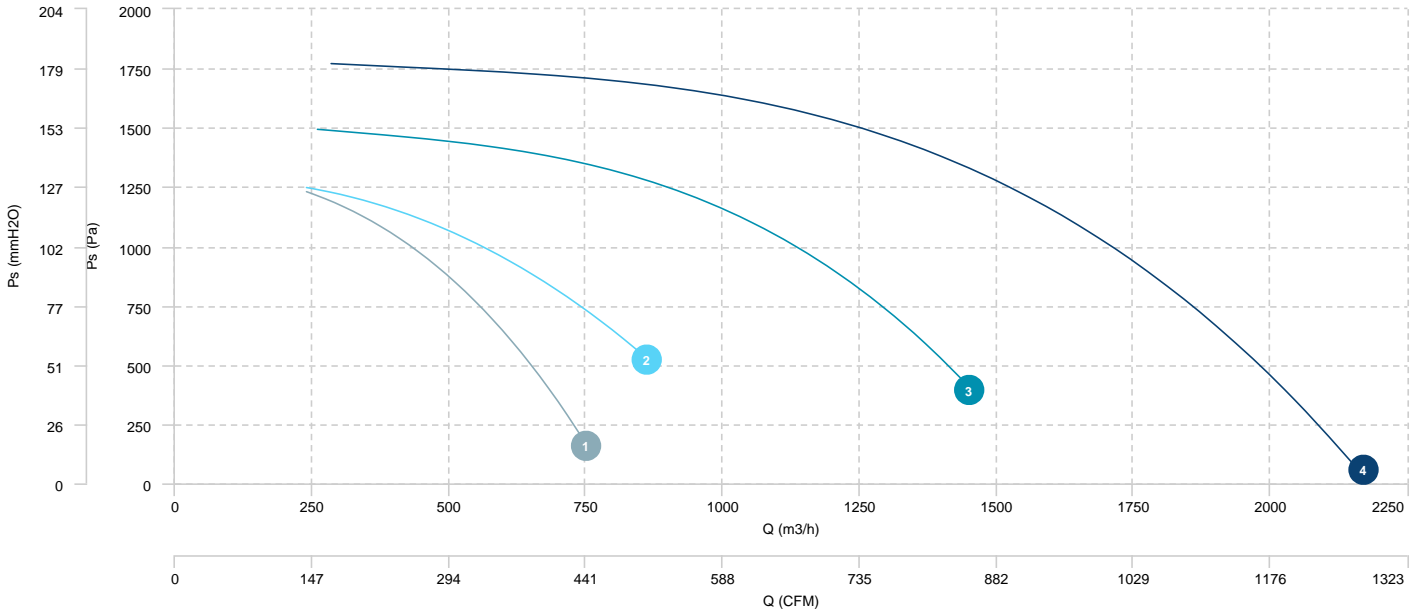

AIR FLOW - ABSORBED POWER

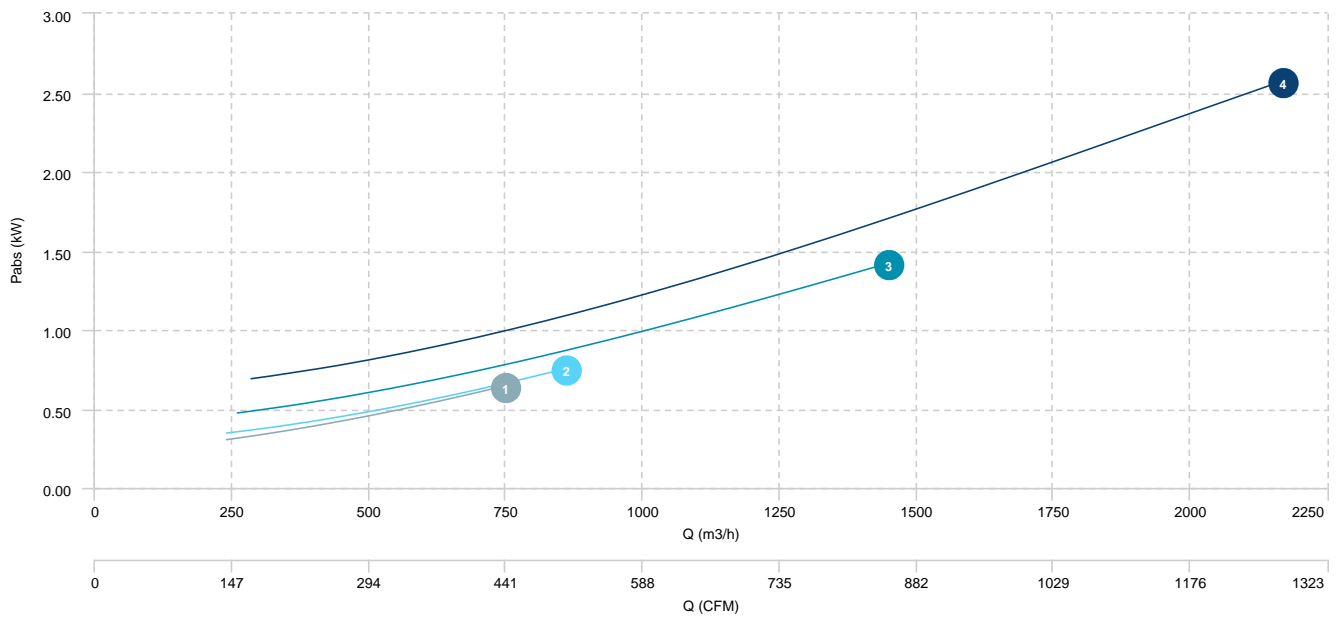

Sound data

Sound power Lw dB (A)										
Model		63 Hz	125 Hz	250 Hz	500 Hz	1000 Hz	2000 Hz	4000 Hz	8000 Hz	Total
MA 26 M2 0,37kW	Inlet	38	60	76	82	86	83	78	69	89
MA 26 T2 0,37kW	Inlet	38	60	76	82	86	83	78	69	89
MA 27 T2 0,55kW	Inlet	41	63	79	84	88	85	80	71	92
MA 28 T2 1,1kW	Inlet	43	65	81	87	91	88	83	74	94
MA 31 T2 2,2kW	Inlet	47	69	84	90	94	91	86	77	98

erp data

ERP	
Fan type	Centrifugal fan radial or forward blades
Installation category	B
Efficiency category	Total
The fan has to be installed with FSC	No

Model	Motor power (kW)	Maximum efficiency point data						
		Max. efficiency (%)	Efficiency grade (N) (N)	Air Flow (m3/h)	Pt (Pa)	Pabs (kW)	speed (rpm)	Specific ratio
MA 26 M2 0,37kW	0,37	32,10	40,99	400,44	1.116,42	0,39	2800	1,00
MA 26 T2 0,37kW	0,37	32,10	40,99	400,44	1.116,42	0,39	2800	1,00
MA 27 T2 0,55kW	0,55	32,91	41,16	520,05	1.114,42	0,50	2800	1,00
MA 28 T2 1,1kW	1,1	41,65	48,32	873,53	1.464,96	0,88	2800	1,00
MA 31 T2 2,2kW	2,2	40,62	46,22	1.085,59	1.711,05	1,31	2800	1,00