

MA P/R



MEDIUM PRESSURE FAN WITH STRAIGHT IMPELLER

MANUFACTURING FEATURES:

- Cast aluminium housing.
- Straight blade steel sheet or cast aluminium impellers.
- Epoxy powder coat finishing.
- Squirrel cage asynchronous standard motor, IP-55 protection and rated class F insulation. Standard voltages 230/400V 50Hz.
- Standard orientation: LG270.

APPLICATIONS:

Designed for inline installation, they are suitable for:

- Solid material transport (except for textile fibers).
- Maximum working temperature: carried air: 130°C, ambient: 60°C.

Accessories



AC



FILTRO
EMC



INT



JE-45



SFC

UNDER REQUEST:

- 60Hz fans and special voltages.
- 2 speed motors.
- Orientation: LG0, LG45, LG90, LG135, LG180 i LG315.

Technical data

Three-phase motor

Code	Model	R.P.M.	Rated I. (A) 400V	Rated power kW	Max. Airflow m3/h	Sound db (A)*	Weight	Connect. diagram
253300160	MA 26 T2 0,37kW P/R	2800	0,91	0,37	700	51	14	1
300006000	MA 27 T2 0,55kW P/R	2800	1,29	0,55	850	53	16	1
300140600	MA 28 T2 0,75kW P/R	2800	1,58	0,75	1.400	55	21	1
300032600	MA 31 T2 1,5kW P/R	2800	3,14	1,50	1.800	58	25	1

Notes:
 * Total sound pressure level at the point of maximum flow measured in dB(A) in the suction measured in free field at a distance of 6m from the source

Dimensions

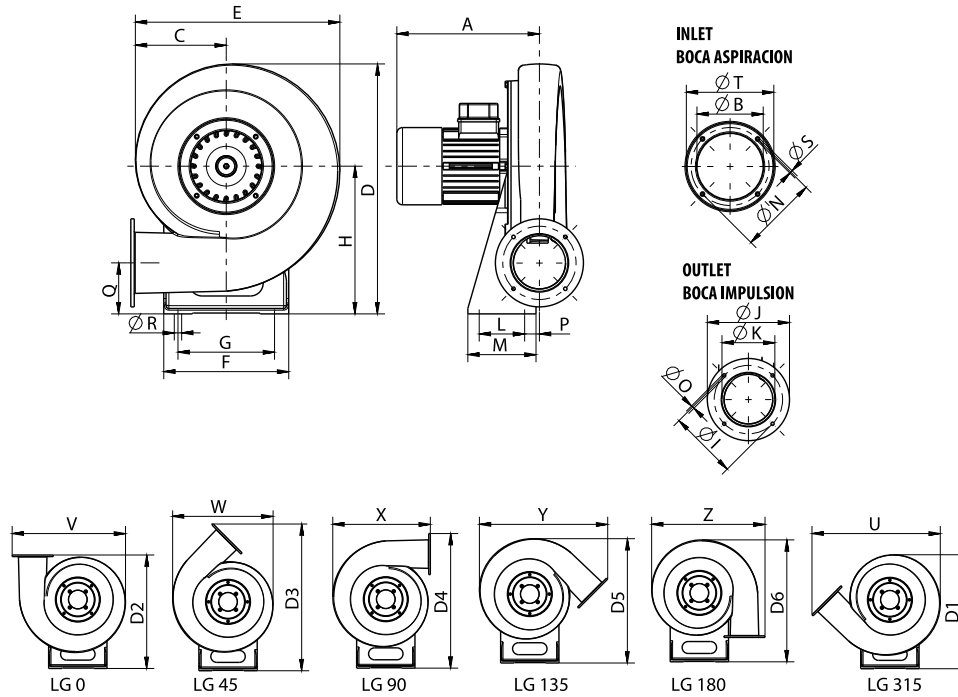

Model	A	BØ	C	D	D1	D2	D3	D4	D5
MA 26 T2 0,37kW P/R	240	110	162	413	405	402	519	473	440
MA 27 T2 0,55kW P/R	250	125	168	440	431	428	552	505	470
MA 28 T2 0,75kW P/R	275	125	168	440	470	468	605	558	516
MA 31 T2 1,5kW P/R	320	160	193	530	518	513	668	620	568

Model	D6	E	F	G	H	I	J	KØ	L
MA 26 T2 0,37kW P/R	431	353	210	160	240	90	140	119	65
MA 27 T2 0,55kW P/R	460	368	220	170	260	100	155	129	80
MA 28 T2 0,75kW P/R	505	393	230	180	290	134,5	182	160	100
MA 31 T2 1,5kW P/R	555	428	240	190	323	145	200	175	120

Model	M	NØ	OØ	P	Q	RØ	S	T	U
MA 26 T2 0,37kW P/R	105	132	6,2	18,5	77	13	M6	152	460
MA 27 T2 0,55kW P/R	120	147	6,2	26	90	13	M6	165	482
MA 28 T2 0,75kW P/R	140	162	10,2	20	113	13	M6	187	518
MA 31 T2 1,5kW P/R	160	180	10,2	18,5	122	13	M6	215	570

Model	V	W	X	Y	Z
MA 26 T2 0,37kW P/R	406	363	353	460	406
MA 27 T2 0,55kW P/R	425	381	168	482	425

Model	V	W	X	Y	Z
MA 28 T2 0,75kW P/R	460	406	393	518	460
MA 31 T2 1,5kW P/R	510	445	428	570	510

Wiring diagram

DIAGRAM Nº 1

230/400V

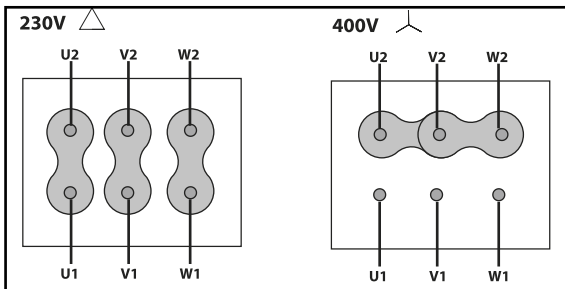

400/690V

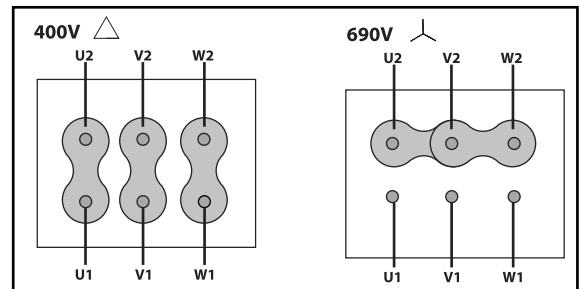

CHARACTERISTIC CURVE

- 1 MA 26 T2 0,37kW P/R
- 2 MA 27 T2 0,55kW P/R
- 3 MA 28 T2 0,75kW P/R
- 4 MA 31 T2 1,5kW P/R

AIR FLOW - PRESSURE

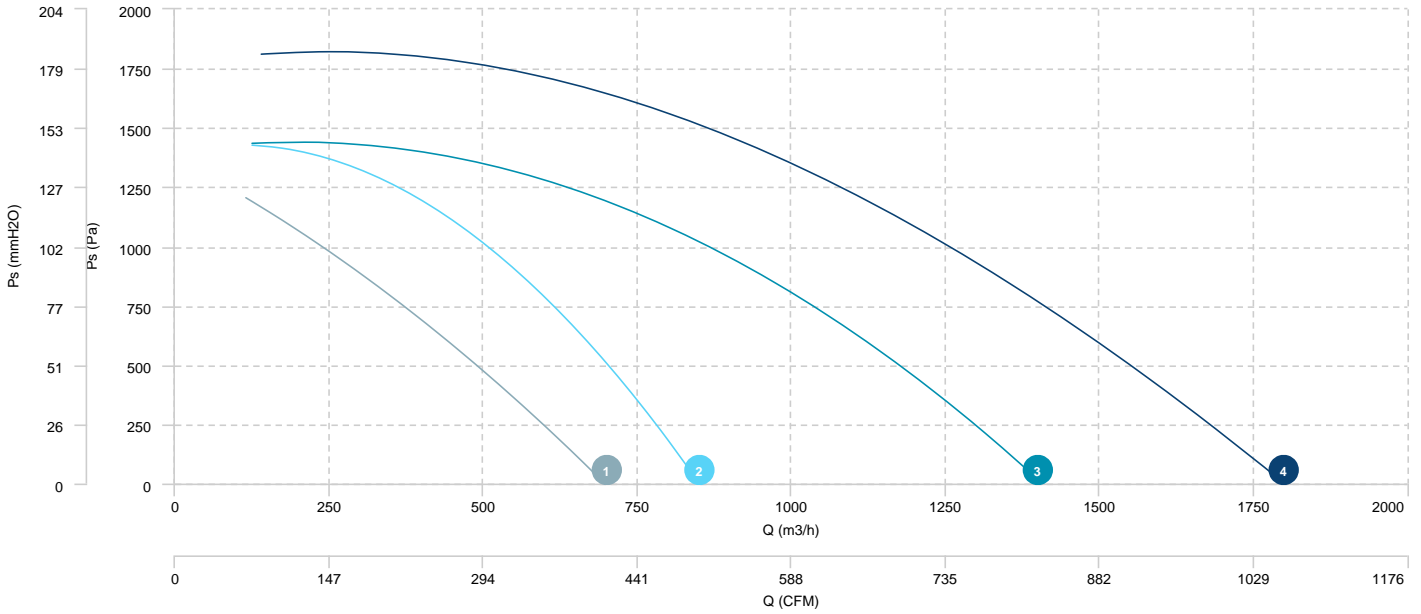

Sound data

Sound power Lw dB (A)										
Model		63 Hz	125 Hz	250 Hz	500 Hz	1000 Hz	2000 Hz	4000 Hz	8000 Hz	Total
MA 26 T2 0,37kW P/R	Inlet	38	44	68	75	72	65	56	48	77
MA 27 T2 0,55kW P/R	Inlet	40	46	70	77	74	67	58	50	79
MA 28 T2 0,75kW P/R	Inlet	42	48	72	79	76	69	60	52	81
MA 31 T2 1,5kW P/R	Inlet	45	51	75	82	79	72	63	55	84