

MBZM P/R



MEDIUM PRESSURE FAN WITH STRAIGHT IMPELLER

MANUFACTURING FEATURES:

- Fan made of Fe360 sheet. The fan paint finish is based on a Qualicoat polyester powder coating stoved at 200°C, with an average film thickness of 70 microns. Average heat resistance of coating is 180°C with peaks of 200°C.
- Fully welded or joined housing.
- Simple inlet straight blade impeller made of Fe360 sheet statically and dynamically balanced.

Impellers are painted with epoxy primer that resists temperatures up to 300°C.

- Standard asynchronous squirrel-cage motor with IP-55 protection and class F insulation. Manufactured with standard voltages: 230V 50Hz in single phase motors and 230/400V 50Hz in three phase motors up to 4kW and 400/690V 50Hz for higher powers.

- Standard orientation LG270.
- It allows adjusting the orientation locally from models 220 to 630. Models sizes from 710 to 1000 size the orientation is fixed.

APPLICATIONS:

Designed for inline installation, they are suitable for:

- Solid material and textile fibers transport.
- Maximum working temperature: carried air: 130°C, ambient: 60°C.

UNDER REQUEST:

- 60Hz fans and special voltages.
- 2 speed motors.
- Spark-proof fans with ATEX certified motor.
- Fan for air working temperatures up to 250°C with R/R (cooling impeller).
- Hot-dipped galvanised or stainless steel fans.
- Orientation: RD0, RD45, RD90, RD135, RD180, RD225, RD270, RD315, LG0, LG45, LG90, LG135, LG180, LG225, LG315.

Accessories



AC



BAD



EI



FILTRO
EMC



INT



JE-45



SFC

Technical data

Three-phase motor / 2 poles

Code	Model	R.P.M.	Rated I. (A) 400V	Rated power kW	Max. Airflow m ³ /h	Sound db (A)*	Weight	Connect. diagram
501502215	MBZM 220 T2 0,37kW P/R	2800	0,91	0,37	870	51	20	1
501502516	MBZM 251 T2 0,55kW P/R	2800	1,29	0,55	1.080	55	25	1
501502517	MBZM 252 T2 0,75kW P/R	2800	1,58	0,75	1.230	56	30	1
501502818	MBZM 281 T2 1,1kW P/R	2800	2,33	1,10	1.370	57	33	1
501502819	MBZM 282 T2 1,5kW P/R	2800	3,14	1,50	1.800	59	37	1
501503119	MBZM 311 T2 1,5kW P/R	2800	3,14	1,50	1.620	58	43	1
501503127	MBZM 312 T2 2,2kW P/R	2800	4,58	2,20	2.160	61	47	1
501503529	MBZM 351 T2 3kW P/R	2870	5,92	3	2.520	63	63	1
501503532	MBZM 352 T2 4kW P/R	2890	7,63	4	3.600	65	72	1
501504034	MBZM 401 T2 5,5kW P/R	2900	10,6	5,50	4.320	67	101	1
501504036	MBZM 402 T2 7,5kW P/R	2900	14,1	7,50	5.400	68	106	1
501504521	MBZM 452 T2 11kW P/R	2930	20,8	11	7.200	71	155	1
501505024	MBZM 501 T2 15kW P/R	2930	27,4	15	9.000	73	180	1
501505028	MBZM 502 T2 22kW P/R	2940	39,8	22	10.800	74	250	1

Three-phase motor / 4 poles

Code	Model	R.P.M.	Rated I. (A) 400V	Rated power kW	Max. Airflow m ³ /h	Sound db (A)*	Weight	Connect. diagram
501504546	MBZM 454 T4 1,5kW P/R	1400	3,26	1,50	3.600	57	85	1
501505054	MBZM 503 T4 2,2kW P/R	1430	4,64	2,20	4.680	56	112	1
501505056	MBZM 504 T4 3kW P/R	1430	6,17	3	5.400	60	117	1
501505659	MBZM 561 T4 4kW P/R	1440	8,32	4	6.120	61	156	1
501505661	MBZM 562 T4 5,5kW P/R	1440	10,5	5,50	7.200	63	177	1
501506363	MBZM 631 T4 7,5kW P/R	1440	14,1	7,50	7.920	64	202	1
501506349	MBZM 632 T4 11kW P/R	1460	21,2	11	10.080	66	250	1
501507149	MBZM 711 T4 11kW P/R	1460	21,2	11	12.600	68	358	1
501507152	MBZM 712 T4 15kW P/R	1460	29,8	15	12.600	68	370	1
501508053	MBZM 801 T4 18,5kW P/R	1465	35,6	18,50	19.800	70	526	1
501508057	MBZM 802 T4 30kW P/R	1475	56,3	30	21.600	72	639	1
501509058	MBZM 901 T4 37kW P/R	1475	69,2	37	28.800	74	782	1
501509060	MBZM 902 T4 45kW P/R	1475	80,7	45	28.800	75	817	1
501510062	MBZM 1001 T4 55kW P/R	1480	97,1	55	36.000	76	1.083	1
501510064	MBZM 1002 T4 75kW P/R	1480	133	75	42.120	77	1.227	1

Notes:

* Total sound pressure level at the point of maximum flow measured in dB(A) in the suction measured in free field at a distance of 6m from the source

Dimensions

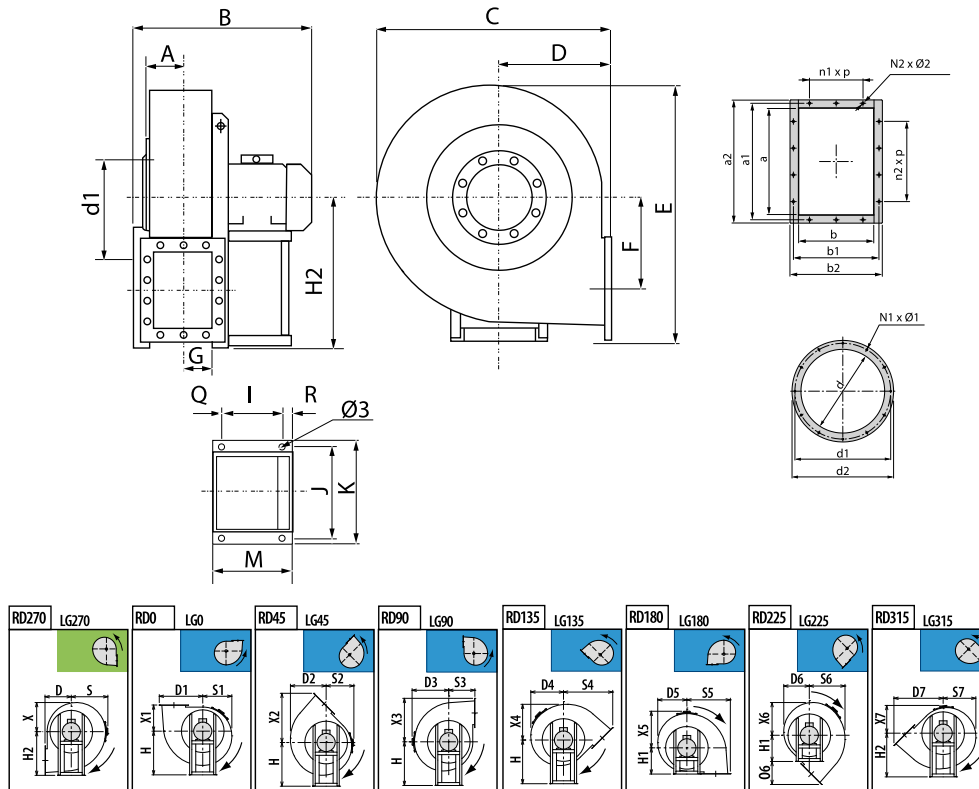

Model	A	B	C	D	D1	D2	D3	D4	D5
MBZM 220 T2 0,37kW P/R	62	337	391	165	232	200	226	190	175
MBZM 251 T2 0,55kW P/R	86	396	471	195	314	255	276	235	212
MBZM 252 T2 0,75kW P/R	86	420	471	195	314	255	276	235	212
MBZM 281 T2 1,1kW P/R	95	438	505	200	353	287	305	262	231
MBZM 282 T2 1,5kW P/R	95	485	505	200	353	287	305	262	231
MBZM 311 T2 1,5kW P/R	105	505	557	225	393	316	332	288	256
MBZM 312 T2 2,2kW P/R	105	505	557	225	393	316	332	288	256
MBZM 351 T2 3kW P/R	115	561	630	255	437	359	375	325	288
MBZM 352 T2 4kW P/R	115	582	630	255	437	359	375	325	288
MBZM 401 T2 5,5kW P/R	127	646	685	306	487	387	400	353	311
MBZM 402 T2 7,5kW P/R	127	646	685	306	487	387	400	353	311
MBZM 452 T2 11kW P/R	141	778	765	320	542	435	445	398	354
MBZM 454 T4 1,5kW P/R	141	581	765	320	542	435	445	398	354
MBZM 501 T2 15kW P/R	157	810	862	360	597	490	502	450	400
MBZM 502 T2 22kW P/R	157	891	862	360	597	490	502	450	400
MBZM 503 T4 2,2kW P/R	157	644	862	360	597	490	502	450	400
MBZM 504 T4 3kW P/R	157	644	862	360	597	490	502	450	400

Model	D6	D7	E	F	G	H	H1	H2	I
MBZM 220 T2 0,37kW P/R	190	280	430	150	55	165	165	255	121
MBZM 251 T2 0,55kW P/R	215	360	527	175	77	315	195	315	121
MBZM 252 T2 0,75kW P/R	215	360	527	175	77	315	195	315	121
MBZM 281 T2 1,1kW P/R	226	391	606	202	86	375	200	375	121
MBZM 282 T2 1,5kW P/R	226	391	606	202	86	375	200	375	133
MBZM 311 T2 1,5kW P/R	253	437	656	229	96	400	225	400	133
MBZM 312 T2 2,2kW P/R	253	437	656	229	96	400	225	400	133
MBZM 351 T2 3kW P/R	278	489	738	253	106	450	255	450	197
MBZM 352 T2 4kW P/R	278	489	738	253	106	450	255	450	197
MBZM 401 T2 5,5kW P/R	306	546	811	286	118	500	285	500	237
MBZM 402 T2 7,5kW P/R	306	546	811	286	118	500	285	500	237
MBZM 452 T2 11kW P/R	342	609	914	321	132	560	320	560	337
MBZM 454 T4 1,5kW P/R	342	609	914	321	132	560	320	560	133
MBZM 501 T2 15kW P/R	380	677	1000	355	148	600	360	600	337
MBZM 502 T2 22kW P/R	380	677	1000	355	148	600	360	600	357
MBZM 503 T4 2,2kW P/R	380	677	1000	355	148	600	360	600	197
MBZM 504 T4 3kW P/R	380	677	1000	355	148	600	360	600	197

Model	J	K	M	N1xØ1	N2xØ2	O6	Q	R	S
MBZM 220 T2 0,37kW P/R	203	225	195	4x4	4x8	115	48	26	226
MBZM 251 T2 0,55kW P/R	203	225	195	8x8	8x12	165	48	26	276
MBZM 252 T2 0,75kW P/R	203	225	217	8x8	8x12	165	48	48	276
MBZM 281 T2 1,1kW P/R	203	225	217	8x8	8x12	191	48	48	305
MBZM 282 T2 1,5kW P/R	234	260	251	8x8	8x12	191	58	60	305
MBZM 311 T2 1,5kW P/R	234	260	246	8x8	10x12	212	55	58	332
MBZM 312 T2 2,2kW P/R	234	260	246	8x8	10x12	212	55	17	332
MBZM 351 T2 3kW P/R	289	324	276	8x10	10x12	234	30	49	375
MBZM 352 T2 4kW P/R	289	324	276	8x10	10x12	234	30	23	375
MBZM 401 T2 5,5kW P/R	337	372	336	8x12	10x12	261	40	59	400
MBZM 402 T2 7,5kW P/R	337	372	336	8x12	10x12	261	40	59	400
MBZM 452 T2 11kW P/R	395	440	436	8x12	10x12	289	50	49	445
MBZM 454 T4 1,5kW P/R	234	260	246	8x12	10x12	289	55	58	445
MBZM 501 T2 15kW P/R	395	440	436	8x12	14x12	317	50	49	502
MBZM 502 T2 22kW P/R	434	488	460	8x12	14x12	317	70	33	502
MBZM 503 T4 2,2kW P/R	289	324	276	8x12	14x12	317	30	49	502
MBZM 504 T4 3kW P/R	289	324	276	8x12	14x12	317	30	49	502

Model	S1	S2	S3	S4	S5	S6	S7	X	X1
MBZM 220 T2 0,37kW P/R	175	190	165	280	232	200	190	175	165
MBZM 251 T2 0,55kW P/R	212	215	195	360	314	255	235	212	195

Model	S1	S2	S3	S4	S5	S6	S7	X	X1
MBZM 252 T2 0,75kW P/R	212	215	195	360	314	255	235	212	195
MBZM 281 T2 1,1kW P/R	231	226	200	391	353	287	262	231	200
MBZM 282 T2 1,5kW P/R	231	226	200	391	353	287	262	231	200
MBZM 311 T2 1,5kW P/R	256	253	225	437	393	316	288	256	225
MBZM 312 T2 2,2kW P/R	256	253	225	437	393	316	288	256	225
MBZM 351 T2 3kW P/R	288	278	255	489	437	359	325	288	255
MBZM 352 T2 4kW P/R	288	278	255	489	437	359	325	288	255
MBZM 401 T2 5,5kW P/R	311	306	285	546	487	387	353	311	285
MBZM 402 T2 7,5kW P/R	311	306	285	546	487	387	353	311	285
MBZM 452 T2 11kW P/R	354	342	320	609	542	435	398	354	320
MBZM 454 T4 1,5kW P/R	354	342	320	609	542	435	398	354	320
MBZM 501 T2 15kW P/R	400	380	360	677	597	490	450	400	360
MBZM 502 T2 22kW P/R	400	380	360	677	597	490	450	400	360
MBZM 503 T4 2,2kW P/R	400	380	360	677	597	490	450	400	360
MBZM 504 T4 3kW P/R	400	380	360	677	597	490	450	400	360

Model	X2	X3	X4	X5	X6	X7	a	a1	a2
MBZM 220 T2 0,37kW P/R	280	232	200	226	190	190	124	145	164
MBZM 251 T2 0,55kW P/R	360	314	255	276	235	215	207	241	277
MBZM 252 T2 0,75kW P/R	360	314	255	276	235	215	207	241	277
MBZM 281 T2 1,1kW P/R	391	353	287	305	262	226	231	265	301
MBZM 282 T2 1,5kW P/R	391	353	287	305	262	226	231	265	301
MBZM 311 T2 1,5kW P/R	437	393	316	332	288	253	258	292	328
MBZM 312 T2 2,2kW P/R	437	393	316	332	288	253	258	292	328
MBZM 351 T2 3kW P/R	489	437	359	375	325	278	288	332	368
MBZM 352 T2 4kW P/R	489	437	359	375	325	278	288	332	368
MBZM 401 T2 5,5kW P/R	546	487	387	400	353	306	322	366	402
MBZM 402 T2 7,5kW P/R	546	487	387	400	353	306	322	366	402
MBZM 452 T2 11kW P/R	609	542	435	445	398	342	361	405	441
MBZM 454 T4 1,5kW P/R	609	542	435	445	398	342	361	405	441
MBZM 501 T2 15kW P/R	677	597	490	502	450	380	404	448	484
MBZM 502 T2 22kW P/R	677	597	490	502	450	380	404	448	484
MBZM 503 T4 2,2kW P/R	677	597	490	502	450	380	404	448	484
MBZM 504 T4 3kW P/R	677	597	490	502	450	380	404	448	484

Model	b	b1	b2	d	d1	d2	n1xp	n2xp	Ø3
MBZM 220 T2 0,37kW P/R	103	125	143	130	150	170	-	-	10
MBZM 251 T2 0,55kW P/R	148	182	218	185	219	250	1x112	1x112	10
MBZM 252 T2 0,75kW P/R	148	182	218	185	219	250	1x112	1x112	10
MBZM 281 T2 1,1kW P/R	166	200	236	205	241	275	1x112	1x112	10

Model	b	b1	b2	d	d1	d2	n1xp	n2xp	Ø3
MBZM 282 T2 1,5kW P/R	166	200	236	205	241	275	1x112	1x112	10
MBZM 311 T2 1,5kW P/R	185	219	255	228	265	298	1x112	2x112	10
MBZM 312 T2 2,2kW P/R	185	219	255	228	265	298	1x112	2x112	10
MBZM 351 T2 3kW P/R	205	249	285	255	292	325	1x125	2x125	12
MBZM 352 T2 4kW P/R	205	249	285	255	292	325	1x125	2x125	12
MBZM 401 T2 5,5kW P/R	229	273	309	285	332	365	1x125	2x125	12
MBZM 402 T2 7,5kW P/R	229	273	309	285	332	365	1x125	2x125	12
MBZM 452 T2 11kW P/R	256	300	336	320	366	400	1x125	2x125	14
MBZM 454 T4 1,5kW P/R	256	300	336	320	366	400	1x125	2x125	10
MBZM 501 T2 15kW P/R	288	332	368	360	405	440	2x125	3x125	14
MBZM 502 T2 22kW P/R	288	332	368	360	405	440	2x125	3x125	17
MBZM 503 T4 2,2kW P/R	288	332	368	360	405	440	2x125	3x125	12
MBZM 504 T4 3kW P/R	288	332	368	360	405	440	2x125	3x125	12

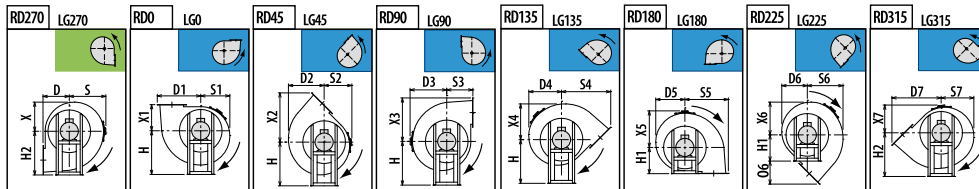
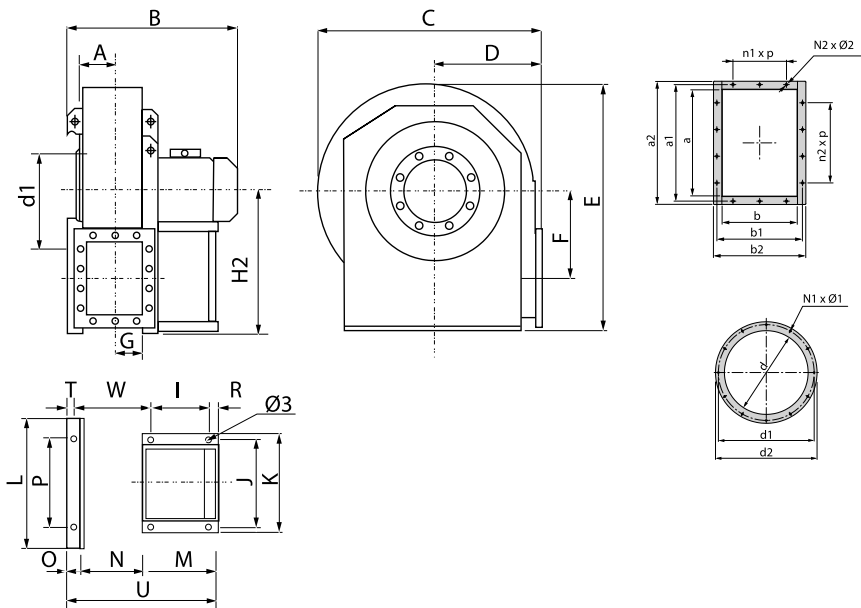

Model	A	B	C	D	D1	D2	D3	D4	D5
MBZM 561 T4 4kW P/R	177	712	970	400	657	555	570	542	485
MBZM 562 T4 5,5kW P/R	177	752	970	400	657	555	570	542	485
MBZM 631 T4 7,5kW P/R	195	792	1080	450	733	619	630	603	550

Model	A	B	C	D	D1	D2	D3	D4	D5
MBZM 632 T4 11kW P/R	195	897	1080	450	733	619	630	603	550

Model	D6	D7	E	F	G	H	H1	H2	I
MBZM 561 T4 4kW P/R	425	747	1155	390	165	670	400	670	197
MBZM 562 T4 5,5kW P/R	425	747	1155	390	165	670	400	670	237
MBZM 631 T4 7,5kW P/R	476	836	1300	439	185	750	450	750	237
MBZM 632 T4 11kW P/R	476	836	1300	439	185	750	450	750	337

Model	J	K	L	M	N	N1xØ1	N2xØ2	O	O6
MBZM 561 T4 4kW P/R	289	324	692	277	326	12x12	14x12	53	347
MBZM 562 T4 5,5kW P/R	337	372	692	337	326	12x12	14x12	53	347
MBZM 631 T4 7,5kW P/R	337	372	762	337	366	12x12	14x12	53	386
MBZM 632 T4 11kW P/R	395	440	762	437	366	12x12	14x12	53	386

Model	P	R	S	S1	S2	S3	S4	S5	S6
MBZM 561 T4 4kW P/R	632	49	570	485	425	400	747	657	555
MBZM 562 T4 5,5kW P/R	632	59	570	485	425	400	747	657	555
MBZM 631 T4 7,5kW P/R	702	59	630	550	476	450	836	733	619
MBZM 632 T4 11kW P/R	702	49	630	550	476	450	836	733	619

Model	S7	T	U	W	X	X1	X2	X3	X4
MBZM 561 T4 4kW P/R	542	23	656	387	485	400	747	657	555
MBZM 562 T4 5,5kW P/R	542	23	716	397	485	400	747	657	555
MBZM 631 T4 7,5kW P/R	603	23	755	436	550	450	836	733	619
MBZM 632 T4 11kW P/R	603	23	855	446	550	450	836	733	619

Model	X5	X6	X7	a	a1	a2	b	b1	b2
MBZM 561 T4 4kW P/R	570	542	425	453	497	533	322	366	402
MBZM 562 T4 5,5kW P/R	570	542	425	453	497	533	322	366	402
MBZM 631 T4 7,5kW P/R	630	603	476	507	551	587	361	405	441
MBZM 632 T4 11kW P/R	630	603	476	507	551	587	361	405	441

Model	d	d1	d2	n1xp	n2xp	Ø3
MBZM 561 T4 4kW P/R	405	448	485	2x125	3x125	12
MBZM 562 T4 5,5kW P/R	405	448	485	2x125	3x125	12
MBZM 631 T4 7,5kW P/R	455	497	535	2x125	3x125	12
MBZM 632 T4 11kW P/R	455	497	535	2x125	3x125	14

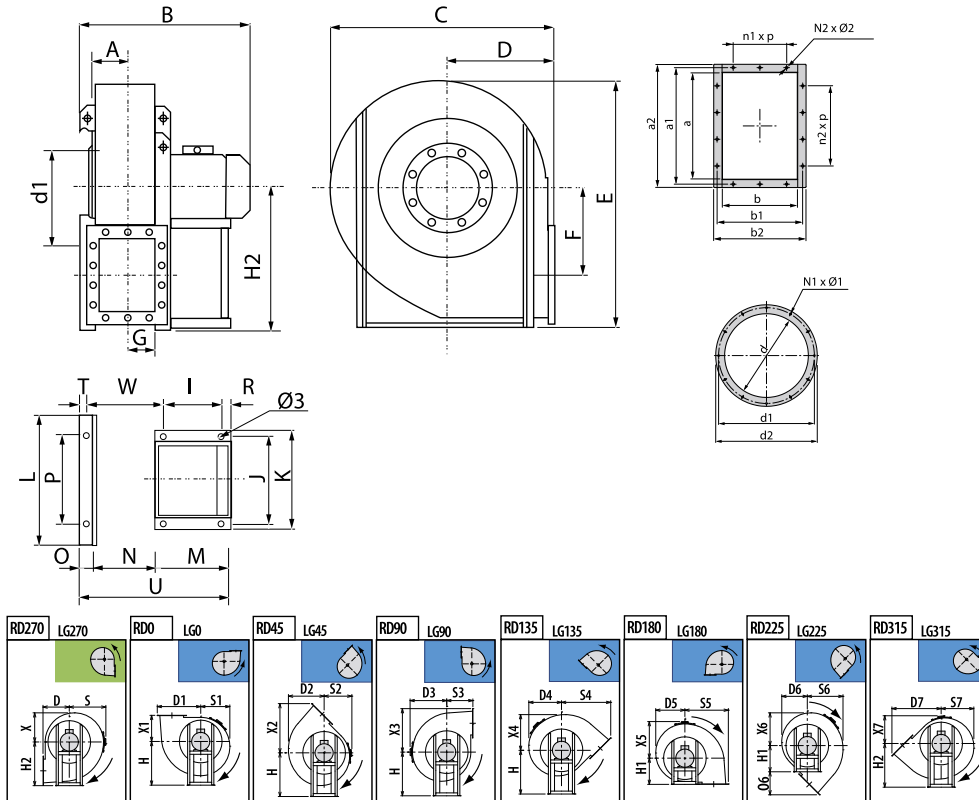

Model	A	B	C	D	D1	D2	D3	D4	D5
MBZM 711 T4 11kW P/R	216	942	1190	500	835	719	690	662	565
MBZM 712 T4 15kW P/R	216	942	1190	500	835	719	690	662	565
MBZM 801 T4 18,5kW P/R	241	1092	1342	560	929	811	782	749	641
MBZM 802 T4 30kW P/R	241	1200	1342	560	929	811	782	749	641
MBZM 901 T4 37kW P/R	275	1236	1500	630	1038	905	870	835	721
MBZM 902 T4 45kW P/R	275	1296	1500	630	1038	905	870	835	721
MBZM 1001 T4 55kW P/R	308	1486	1686	710	1171	1015	976	936	814
MBZM 1002 T4 75kW P/R	308	1489	1686	710	1171	1015	976	936	814

Model	D6	D7	E	F	G	H	H1	H2	I
MBZM 711 T4 11kW P/R	497	944	1415	500	202	670	500	850	316
MBZM 712 T4 15kW P/R	497	944	1415	500	202	670	500	850	316
MBZM 801 T4 18,5kW P/R	562	1053	1591	560	226	755	560	950	361
MBZM 802 T4 30kW P/R	562	1053	1591	560	226	755	560	950	401
MBZM 901 T4 37kW P/R	633	1180	1781	1038	253	850	630	1060	441
MBZM 902 T4 45kW P/R	633	1180	1781	1038	253	850	630	1060	441
MBZM 1001 T4 55kW P/R	718	1330	1994	710	284	950	710	1180	500
MBZM 1002 T4 75kW P/R	718	1330	1994	710	284	950	710	1180	590

Model	J	K	L	M	N	N1xØ1	N2xØ2	O	O6
-------	---	---	---	---	---	-------	-------	---	----

Model	J	K	L	M	N	N1xØ1	N2xØ2	O	O6
MBZM 711 T4 11kW P/R	772	826	914	436	404	12x14	14x14	60	444
MBZM 712 T4 15kW P/R	772	826	914	436	404	12x14	14x14	60	444
MBZM 801 T4 18,5kW P/R	862	926	1044	460	453	12x14	14x14	80	493
MBZM 802 T4 30kW P/R	862	926	1044	500	453	12x14	14x14	80	493
MBZM 901 T4 37kW P/R	962	1026	1144	540	507	12x14	16x14	80	550
MBZM 902 T4 45kW P/R	962	1026	1144	540	507	12x14	16x14	80	550
MBZM 1001 T4 55kW P/R	1056	1128	1254	600	569	16x14	14x14	100	620
MBZM 1002 T4 75kW P/R	1056	1128	1254	690	569	16x14	14x14	100	620

Model	P	R	S	S1	S2	S3	S4	S5	S6
MBZM 711 T4 11kW P/R	772	49	690	565	497	500	944	835	719
MBZM 712 T4 15kW P/R	772	49	690	565	497	500	944	835	719
MBZM 801 T4 18,5kW P/R	862	39	782	641	562	560	1053	929	811
MBZM 802 T4 30kW P/R	862	39	782	641	562	560	1053	929	811
MBZM 901 T4 37kW P/R	962	39	870	721	633	630	1180	1038	905
MBZM 902 T4 45kW P/R	962	39	870	721	633	630	1180	1038	905
MBZM 1001 T4 55kW P/R	1056	45	976	814	718	710	1330	1171	1015
MBZM 1002 T4 75kW P/R	1056	45	976	814	718	710	1330	1171	1015

Model	S7	T	U	W	X	X1	X2	X3	X4
MBZM 711 T4 11kW P/R	662	27	889	497	565	500	944	835	719
MBZM 712 T4 15kW P/R	662	27	889	497	565	500	944	835	719
MBZM 801 T4 18,5kW P/R	749	47	993	546	641	560	1053	929	811
MBZM 802 T4 30kW P/R	749	47	1033	546	641	560	1053	929	811
MBZM 901 T4 37kW P/R	835	47	1127	600	721	630	1180	1038	905
MBZM 902 T4 45kW P/R	835	47	1127	600	721	630	1180	1038	905
MBZM 1001 T4 55kW P/R	936	67	1269	657	814	710	1330	1171	1015
MBZM 1002 T4 75kW P/R	936	67	1359	657	814	710	1330	1171	1015

Model	X5	X6	X7	a	a1	a2	b	b1	b2
MBZM 711 T4 11kW P/R	690	662	497	569	629	669	404	464	669
MBZM 712 T4 15kW P/R	690	662	497	569	629	669	404	464	504
MBZM 801 T4 18,5kW P/R	782	749	562	638	698	738	453	513	553
MBZM 802 T4 30kW P/R	782	749	562	638	698	738	453	513	553
MBZM 901 T4 37kW P/R	870	835	633	715	775	815	507	567	607
MBZM 902 T4 45kW P/R	870	835	633	715	775	815	507	567	607
MBZM 1001 T4 55kW P/R	976	936	718	801	871	921	569	639	689
MBZM 1002 T4 75kW P/R	976	936	718	801	871	921	569	639	689

Model	d	d1	d2	n1xp	n2xp	Ø3
-------	---	----	----	------	------	----

Model	d	d1	d2	n1xp	n2xp	Ø3
MBZM 711 T4 11kW P/R	505	551	585	2x160	3x160	20
MBZM 712 T4 15kW P/R	505	551	585	2x160	3x160	20
MBZM 801 T4 18,5kW P/R	565	629	665	2x160	3x160	20
MBZM 802 T4 30kW P/R	565	629	665	2x160	3x160	20
MBZM 901 T4 37kW P/R	635	698	735	2x160	4x160	20
MBZM 902 T4 45kW P/R	635	698	735	2x160	4x160	20
MBZM 1001 T4 55kW P/R	715	775	815	2x200	3x200	20
MBZM 1002 T4 75kW P/R	715	775	815	2x200	3x200	20

Wiring diagram

DIAGRAM Nº 1

230/400V

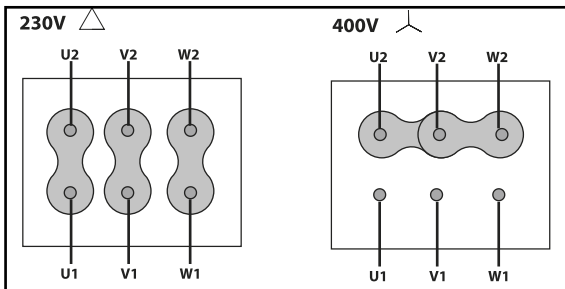

400/690V

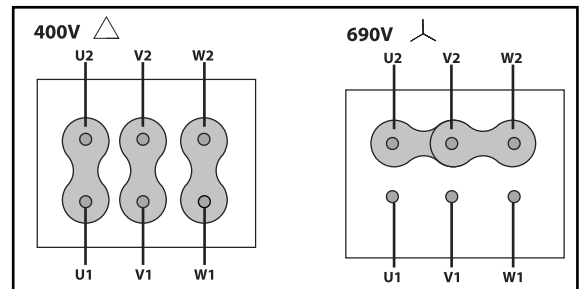

CHARACTERISTIC CURVE

1	MBZM 220 T2 0,37kW P/R	2	MBZM 251 T2 0,55kW P/R	3	MBZM 252 T2 0,75kW P/R	4	MBZM 281 T2 1,1kW P/R
5	MBZM 282 T2 1,5kW P/R	6	MBZM 311 T2 1,5kW P/R	7	MBZM 312 T2 2,2kW P/R		

AIR FLOW - PRESSURE

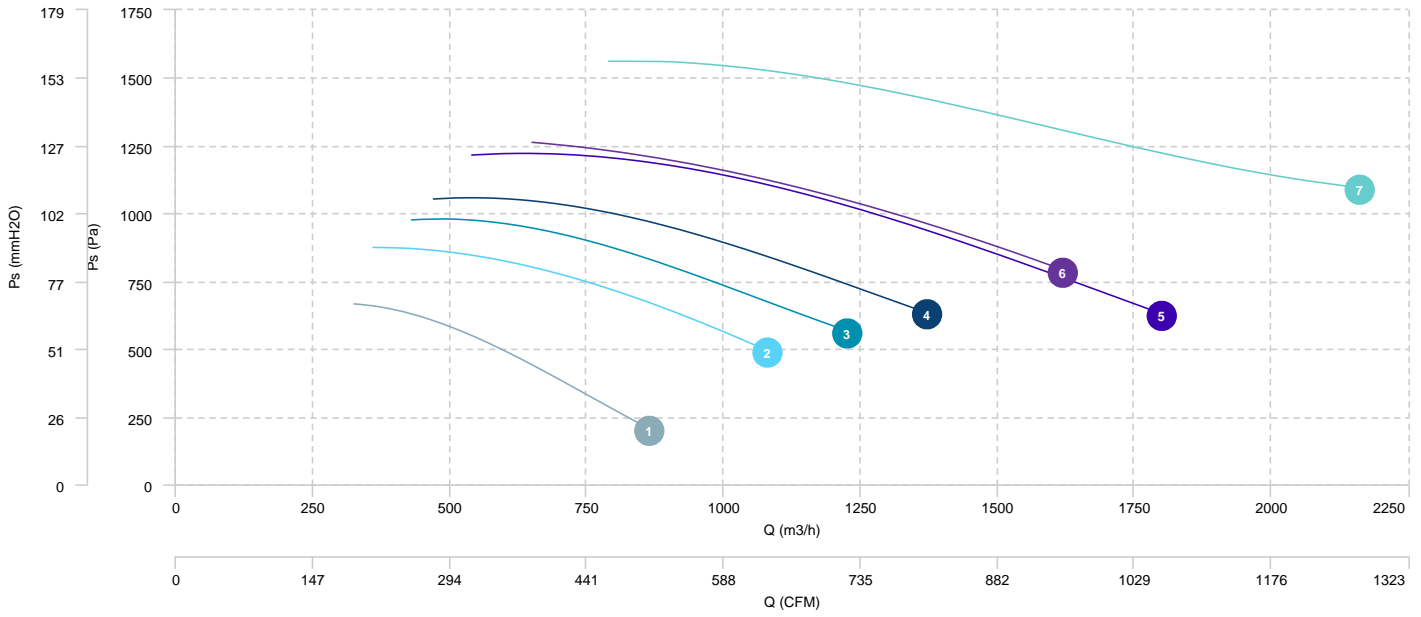

1	MBZM 351 T2 3kW P/R	2	MBZM 352 T2 4kW P/R	3	MBZM 401 T2 5,5kW P/R	4	MBZM 402 T2 7,5kW P/R
5	MBZM 452 T2 11kW P/R	6	MBZM 501 T2 15kW P/R	7	MBZM 502 T2 22kW P/R		

AIR FLOW - PRESSURE

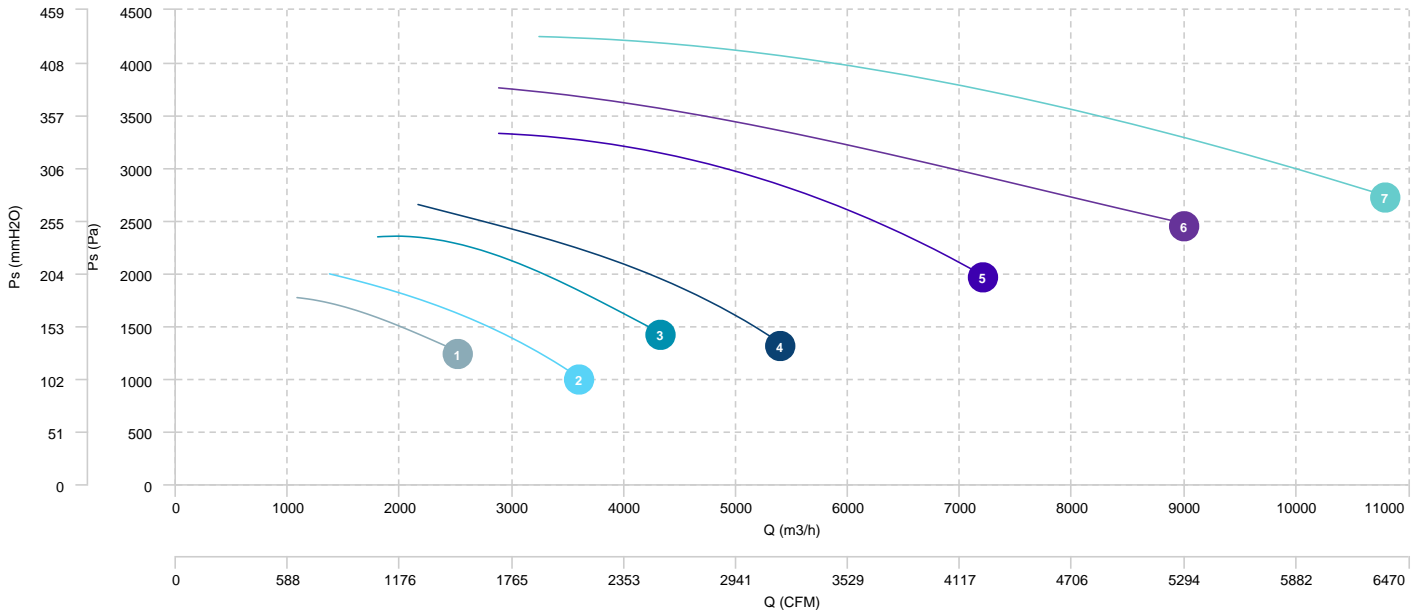

1	MBZM 454 T4 1,5kW P/R	2	MBZM 503 T4 2,2kW P/R	3	MBZM 504 T4 3kW P/R	4	MBZM 561 T4 4kW P/R
5	MBZM 562 T4 5,5kW P/R	6	MBZM 631 T4 7,5kW P/R	7	MBZM 632 T4 11kW P/R	8	MBZM 711 T4 11kW P/R

AIR FLOW - PRESSURE

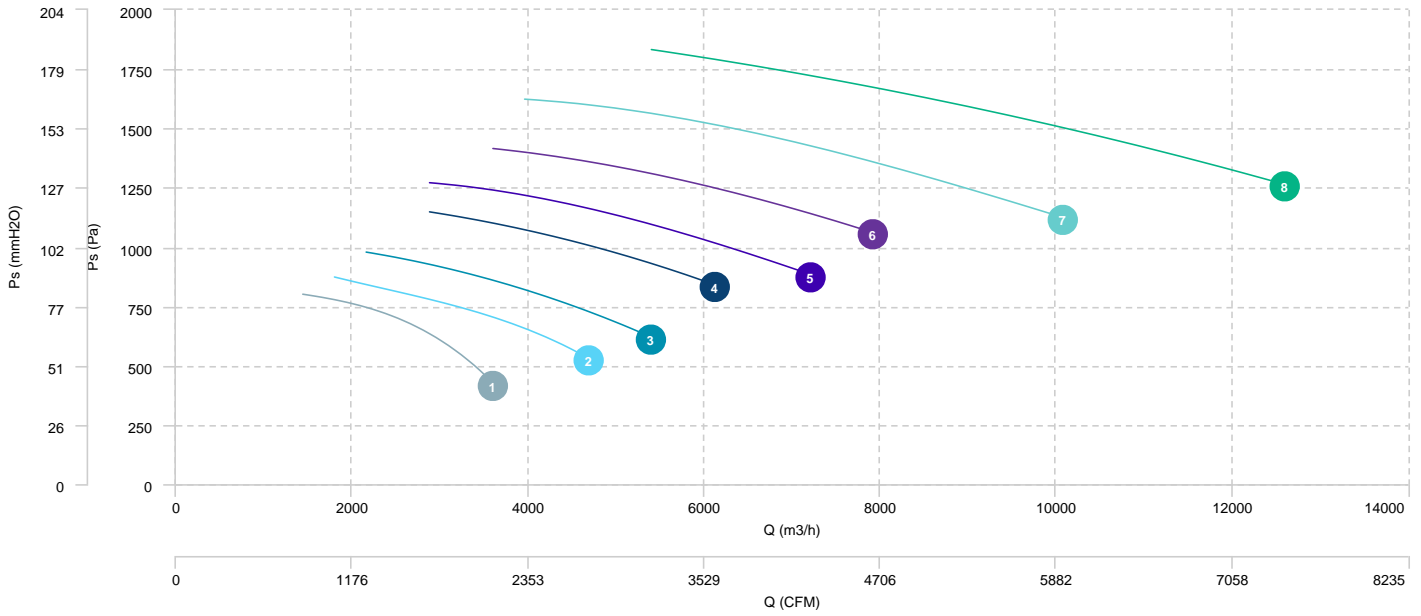

1	MBZM 712 T4 15kW P/R	2	MBZM 801 T4 18,5kW P/R	3	MBZM 802 T4 30kW P/R	4	MBZM 901 T4 37kW P/R
5	MBZM 902 T4 45kW P/R	6	MBZM 1001 T4 55kW P/R	7	MBZM 1002 T4 75kW P/R		

AIR FLOW - PRESSURE

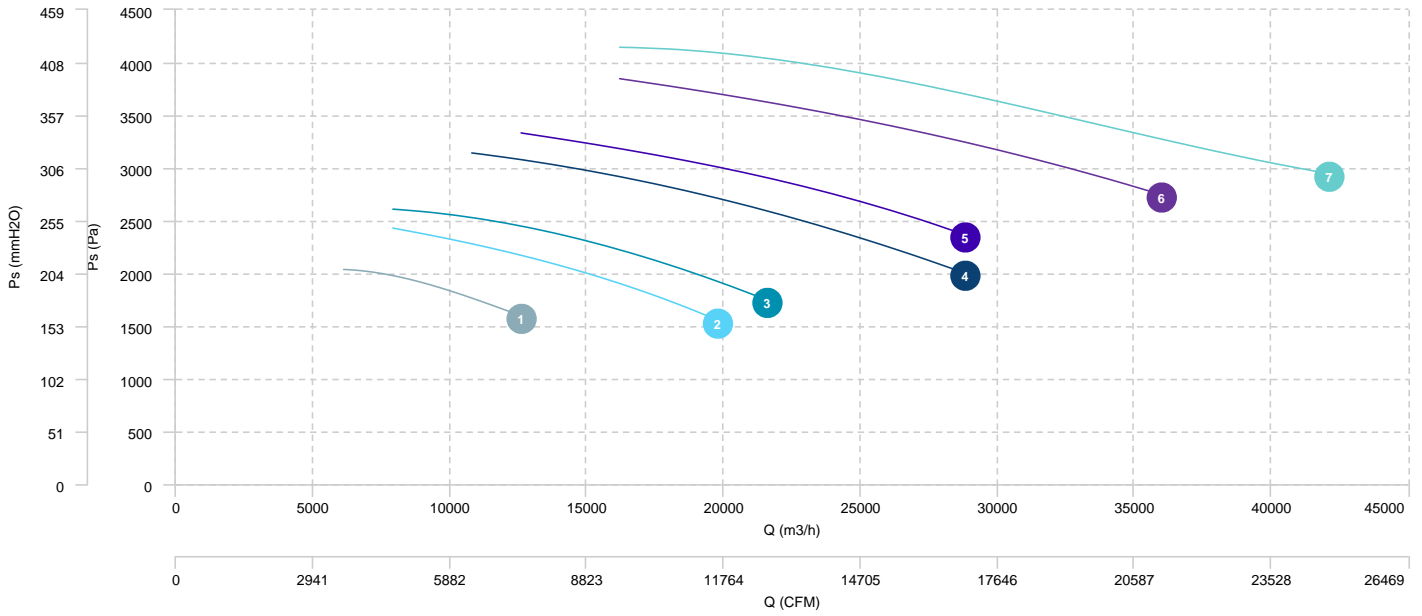

Sound data

Sound / 2 poles

Sound power Lw dB (A)										
Model		63 Hz	125 Hz	250 Hz	500 Hz	1000 Hz	2000 Hz	4000 Hz	8000 Hz	Total
MBZM 220 T2 0,37kW P/R	Inlet	50	62	68	72	73	68	62	59	77
MBZM 251 T2 0,55kW P/R	Inlet	53	65	72	76	77	72	65	62	81
MBZM 252 T2 0,75kW P/R	Inlet	54	66	72	76	77	73	66	63	82
MBZM 281 T2 1,1kW P/R	Inlet	55	67	73	78	78	74	67	64	83
MBZM 282 T2 1,5kW P/R	Inlet	57	69	75	80	80	76	69	66	85
MBZM 311 T2 1,5kW P/R	Inlet	56	68	75	79	80	75	69	66	84
MBZM 312 T2 2,2kW P/R	Inlet	59	71	78	82	83	78	72	69	87
MBZM 351 T2 3kW P/R	Inlet	61	73	80	84	85	80	74	71	89
MBZM 352 T2 4kW P/R	Inlet	63	75	82	86	87	82	75	72	91
MBZM 401 T2 5,5kW P/R	Inlet	65	77	84	88	89	84	77	74	93
MBZM 402 T2 7,5kW P/R	Inlet	67	79	85	89	90	85	79	76	94
MBZM 452 T2 11kW P/R	Inlet	69	81	88	92	93	88	82	79	97
MBZM 501 T2 15kW P/R	Inlet	71	83	90	94	95	90	83	80	99
MBZM 502 T2 22kW P/R	Inlet	73	85	91	95	96	91	85	82	100

Sound / 4 poles

Sound power Lw dB (A)										
Model		63 Hz	125 Hz	250 Hz	500 Hz	1000 Hz	2000 Hz	4000 Hz	8000 Hz	Total
MBZM 454 T4 1,5kW P/R	Inlet	56	68	74	78	79	74	68	65	83
MBZM 503 T4 2,2kW P/R	Inlet	55	67	73	77	78	73	67	64	82
MBZM 504 T4 3kW P/R	Inlet	58	70	77	81	82	77	71	68	86
MBZM 561 T4 4kW P/R	Inlet	60	72	78	82	83	78	72	69	87
MBZM 562 T4 5,5kW P/R	Inlet	61	73	80	84	85	80	74	71	89
MBZM 631 T4 7,5kW P/R	Inlet	62	74	81	85	86	86	75	72	90
MBZM 632 T4 11kW P/R	Inlet	64	76	83	87	88	83	76	73	92
MBZM 711 T4 11kW P/R	Inlet	66	78	85	89	90	85	79	76	94
MBZM 712 T4 15kW P/R	Inlet	66	78	85	89	90	85	79	76	94
MBZM 801 T4 18,5kW P/R	Inlet	69	81	87	91	92	88	81	78	96
MBZM 802 T4 30kW P/R	Inlet	70	82	89	93	94	89	83	80	98
MBZM 901 T4 37kW P/R	Inlet	73	85	91	95	96	91	85	82	100
MBZM 902 T4 45kW P/R	Inlet	73	85	91	95	96	92	85	82	101
MBZM 1001 T4 55kW P/R	Inlet	74	86	92	96	97	93	86	83	102
MBZM 1002 T4 75kW P/R	Inlet	76	88	94	98	99	94	88	85	103