

MB P/R



MEDIUM PRESSURE FAN WITH STRAIGHT IMPELLER

MANUFACTURING FEATURES:

- Rolled steel sheet housing.
- Welded and reinforced housing
- Simple inlet straight blade impeller manufactured of steel sheet and with reinforced with a welded ring protected with epoxy powder finishing coat.
- Epoxy powder finishing coat.
- Squirrel asynchronous squirrel-cage motor with IP-55 protection and rated class F insulation. Standard voltages 230V 50Hz for single phase motors, 230/400V 50Hz for three phase for motors up to 4kW and 400/690V 50Hz for higher powers.
- Standard orientation: LG270.

Accessories



AC



EI



FILTRO
EMC



INT



SFC

APPLICATIONS:

Designed for inline installation, they are suitable for:

- Solid material transport (except for textile fibers).
- Maximum working temperature: carried air: 130°C, ambient 60°C.

UNDER REQUEST:

- Special voltages.
- 2 speed motors.
- Fan for air working temperatures up to 250°C with R/R (cooling impeller).
- Orientation: LG0, LG 45, LG 90, LG 135, LG 180, LG225, LG315, RD0, RD45, RD90, RD135, RD180, RD225, RD 270, RD315.

Technical data

Three-phase motor

Code	Model	R.P.M.	Rated I. (A) 400V	Rated power kW	Max. Airflow m3/h	Sound db (A)*	Weight	Connect. diagram
253210160	MB 22/9 T2 1,1kW P/R	2800	2,33	1,10	2.100	70	23	1
253280160	MB 25/10 T2 1,5kW P/R	2800	3,14	1,50	2.550	72	31	1
253360161	MB 28/11 T2 2,2kW P/R	2800	4,58	2,20	4.500	75	40	1
253450160	MB 31/12 T2 3kW P/R	2870	5,92	3	5.300	77	55	1
253480161	MB 35/14 T2 5,5kW P/R	2900	10,6	5,50	7.800	80	85	1
253510160	MB 40/16 T2 7,5kW P/R	2900	14,1	7,50	9.500	84	103	1
253530160	MB 45/18 T2 11kW P/R	2930	20,8	11	10.500	87	180	1
253530161	MB 45/18 T2 15kW P/R	2930	27,4	15	12.500	88	191	1

Notes:

* Total sound pressure level at the point of maximum flow measured in dB(A) in the suction measured in free field at a distance of 6m from the source

Dimensions

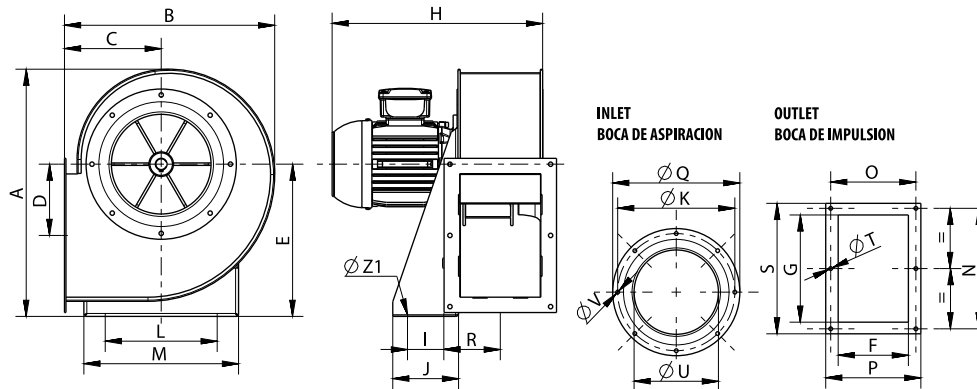

Model	A	B	C	D	E	F	G	H	I
MB 22/9 T2 1,1kW P/R	447	382	181	134	280	140	216	402	50
MB 25/10 T2 1,5kW P/R	496	420	197	142	310	165	254	437	74
MB 28/11 T2 2,2kW P/R	549	468	216	154	340	180	300	477	95

Model	J	K	L	M	N	O	P	Q	R
MB 22/9 T2 1,1kW P/R	110	256	220	290	256	280	204	280	102
MB 25/10 T2 1,5kW P/R	134	282	228	315	290	205	229	306	114,5
MB 28/11 T2 2,2kW P/R	144	320	245	350	340	220	244	348	111,5

Model	S	TØ	UØ	VØ	Z1Ø
MB 22/9 T2 1,1kW P/R	282	9	180	9	11
MB 25/10 T2 1,5kW P/R	314	9	203	9	13
MB 28/11 T2 2,2kW P/R	364	9	228	9	13

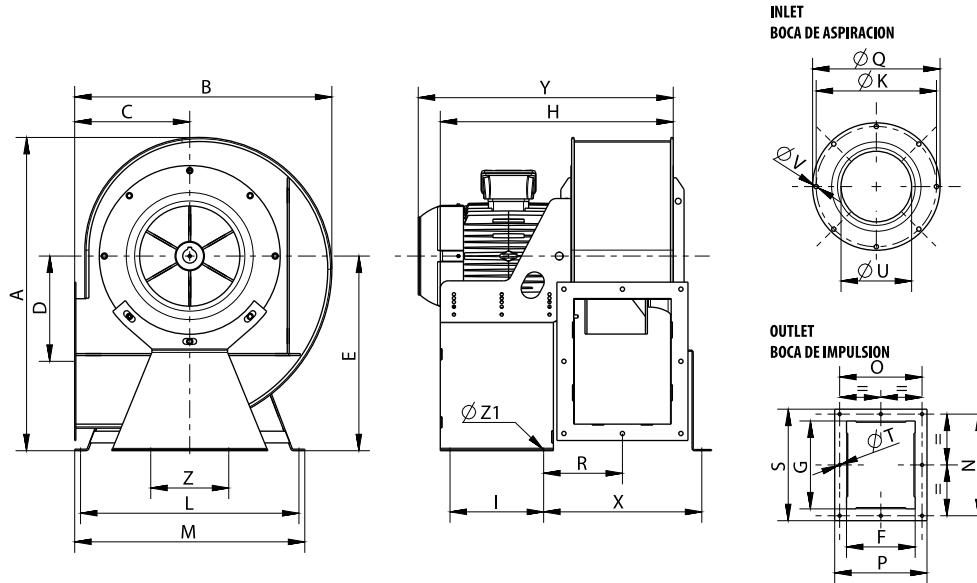

Model	A	B	C	D	E	F	G	H	I
MB 31/12 T2 3kW P/R	640	531	249	180	406	198	319	538	240
MB 35/14 T2 5,5kW P/R	715	587	270	242	451	224	280	564	240
MB 40/16 T2 7,5kW P/R	796	652	295	271	499	250	320	595	240
MB 45/18 T2 11kW P/R	887	730	329	305	553	280	360	791	250
MB 45/18 T2 15kW P/R	887	730	329	305	553	280	360	791	250

Model	J	K	L	M	N	O	P	Q	R
MB 31/12 T2 3kW P/R	290	354,5	457	482	360	240	274	382	171
MB 35/14 T2 5,5kW P/R	290	394,5	449	474	318	266	300	422	184
MB 40/16 T2 7,5kW P/R	290	438	560	590	370	300	336	464	202
MB 45/18 T2 11kW P/R	300	485	602	632	404	328	356	515	207
MB 45/18 T2 15kW P/R	300	485	602	632	404	328	356	515	207

Model	S	TØ	UØ	VØ	X	Y	Z	Z1Ø
MB 31/12 T2 3kW P/R	395	11	203	11	-	533	-	13
MB 35/14 T2 5,5kW P/R	356	11	228	11	-	674	-	13
MB 40/16 T2 7,5kW P/R	406	11	257	11	400	700	200	13
MB 45/18 T2 11kW P/R	436	11	289	11	415	856	200	13
MB 45/18 T2 15kW P/R	436	11	289	11	415	856	200	13

Wiring diagram

DIAGRAM Nº 1

230/400V

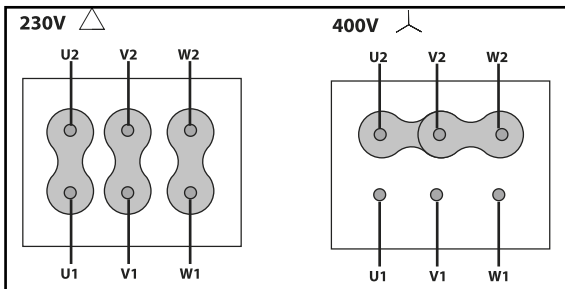

400/690V

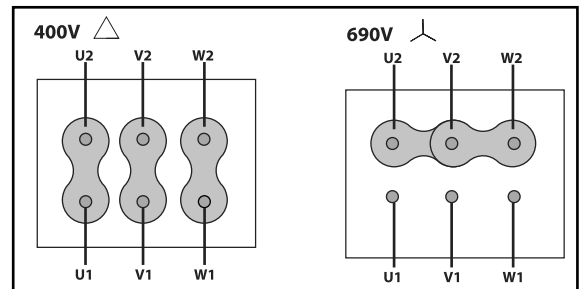

CHARACTERISCTIC CURVE

1	MB 22/9 T2 1,1kW P/R	2	MB 25/10 T2 1,5kW P/R	3	MB 28/11 T2 2,2kW P/R	4	MB 31/12 T2 3kW P/R
5	MB 35/14 T2 5,5kW P/R	6	MB 40/16 T2 7,5kW P/R	7	MB 45/18 T2 11kW P/R	8	MB 45/18 T2 15kW P/R

AIR FLOW - PRESSURE

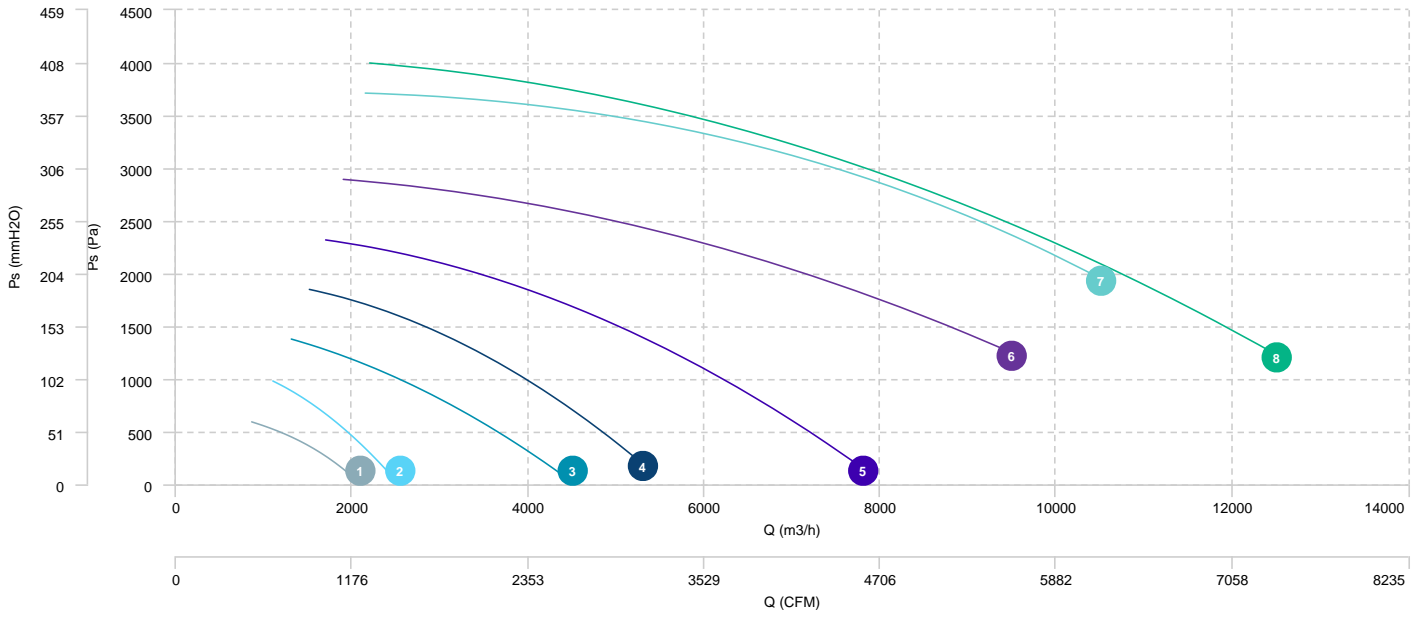

Sound data

Sound power Lw dB (A)										
Model		63 Hz	125 Hz	250 Hz	500 Hz	1000 Hz	2000 Hz	4000 Hz	8000 Hz	Total
MB 22/9 T2 1,1kW P/R	Inlet	59	75	90	90	91	88	86	77	96
MB 25/10 T2 1,5kW P/R	Inlet	61	77	92	92	93	90	88	79	98
MB 28/11 T2 2,2kW P/R	Inlet	64	80	95	95	96	93	91	82	101
MB 31/12 T2 3kW P/R	Inlet	66	82	97	97	98	95	93	84	103
MB 35/14 T2 5,5kW P/R	Inlet	69	85	100	100	101	98	96	87	106
MB 40/16 T2 7,5kW P/R	Inlet	73	89	104	104	105	102	100	91	110
MB 45/18 T2 11kW P/R	Inlet	76	92	107	107	108	105	103	94	113
MB 45/18 T2 15kW P/R	Inlet	77	93	108	108	109	106	104	95	114