

MTRM



MEDIUM PRESSURE WITH BACKWARD IMPELLER AND BELT TRANSMISSION

MANUFACTURING FEATURES:

- Fan made of Fe360 sheet. The fan paint finish is based on a Qualicoat polyester powder coating stoved at 200°C, with an average film thickness of 70 microns. Average heat resistance of coating is 180°C with peaks of 200°C.
- Fully welded housing.
- Single inlet backward curved impeller, manufactured of rolled steel sheet and epoxy powder finishing. Impellers are painted with epoxy primer that resists temperatures up to 300°C.
- Motorized fan with basement (configuration 12). Full equipped fans including: motor, pulleys, belts, belts guard and shaft guard. Fitted over a base plate.
- Standard orientation LG270.
- It allows adjusting the orientation locally from models 220 to 630. Models sizes from 710 to 2000 size the orientation is fixed.

APPLICATIONS:

Designed for inline installation, they are suitable for:

- Industrial applications, extraction or injection of air.
- Cooling of machines and parts.
- Clean air and pneumatic transport.
- Exhaust after filters, separators and cyclones.
- Dusty air or with low load of granulated materials.
- Maximum working temperature: carried air: 200°C, ambient: 60°C.

UNDER REQUEST:

- 60Hz fans and special voltages.
- 2 speed motors.
- Fan with free shaft (configuration 1) or with motor supported on the pedestal side (configuration 9).
- Flameproof or explosion proof fans with ATEX certificated motors.
- Fan for air working temperatures up to 300°C with R/R (cooling impeller).
- Fan for air working temperatures up to 400°C.
- Hot dip galvanised or stainless steel fans.
- Orientation: RD0, RD45, RD90, RD135, RD180, RD225, RD270, RD315, LG0, LG45, LG90, LG135, LG180, LG225, LG315.

Accessories



AC



BAD



EI



INT



JE-45



RA



RI

Technical data

Three-phase motor

Code	Model	R.P.M.	Rated I. (A) 400V	Rated power kW	Max. Airflow m3/h	Sound db (A)*	Weight	Connect. diagram
5044022_R__	MTRM 220	3500	-	1,10	1.000	40	20	1
5044025_R__	MTRM 250	3500	-	1,50	1.560	36	25	1
5044028_R__	MTRM 280	3500	-	2,20	2.180	49	40	1
5044031_R__	MTRM 310	3500	-	4	3.080	51	45	1
5044035_R__	MTRM 350	3500	-	4	4.200	52	75	1
5044040_R__	MTRM 400	3500	-	5,50	7.160	53	86	1
5044045_R__	MTRM 450	3500	-	9	8.910	53	98	1
5044050_R__	MTRM 500	3400	-	11	13.020	55	115	1
5044056_R__	MTRM 560	3300	-	18,50	17.970	54	194	1
5044063_R__	MTRM 630	2500	-	22	19.170	57	229	1
5044071_R__	MTRM 710	2250	-	22	23.350	56	346	1
5044080_R__	MTRM 800	2000	-	37	32.510	58	421	1
5044090_R__	MTRM 900	1800	-	45	40.570	58	517	1
5044100_R__	MTRM 1000	1600	-	55	51.350	59	746	1
5044112_R__	MTRM 1120	1450	-	75	65.040	59	1.040	1
5044125_R__	MTRM 1250	1250	-	75	78.580	61	1.195	1
5044140_R__	MTRM 1400	1100	-	90	96.310	60	1.696	1
5044160_R__	MTRM 1600	950	-	132	130.260	61	2.100	1
5044180_R__	MTRM 1800	900	-	160	156.000	61	2.740	1
5044200_R__	MTRM 2000	800	-	200	199.620	66	3.630	1

Notes:
 * Total sound pressure level at the point of maximum flow measured in dB(A) in the suction measured in free field at a distance of 6m from the source

Dimensions

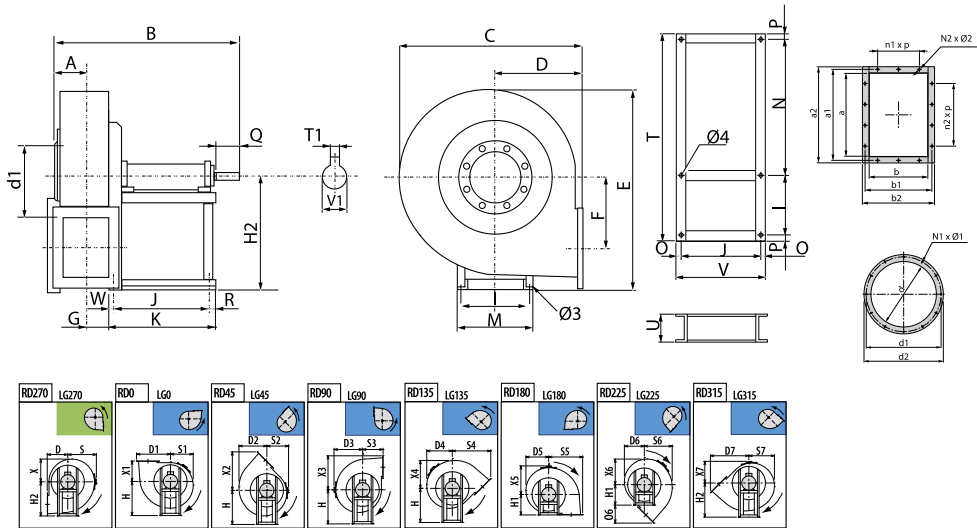

Model	A	B	C	D	D1	D2	D3	D4	D5
MTRM 220	59	455	391	165	232	200	226	190	175
MTRM 250	86	496	471	195	314	255	276	235	212
MTRM 280	95	592	505	200	353	287	305	262	231
MTRM 310	115	783	630	255	393	316	332	288	256
MTRM 350	127	820	685	285	437	359	375	325	288
MTRM 400	127	820	685	285	487	387	400	353	311
MTRM 450	141	847	765	320	542	435	445	398	354
MTRM 500	157	985	862	360	597	490	502	450	400

Model	D6	D7	E	F	G	H	H1	H2	I
MTRM 220	190	280	475	150	55	255	165	300	228
MTRM 250	215	360	527	175	77	315	195	315	228
MTRM 280	226	391	606	202	86	375	200	375	288
MTRM 310	253	437	738	253	106	400	225	450	355
MTRM 350	278	489	811	286	118	450	255	500	355
MTRM 400	306	546	811	286	118	500	285	500	355
MTRM 450	342	609	914	321	132	560	320	560	355
MTRM 500	380	677	1000	355	148	600	360	600	364

Model	J	K	M	N1xØ1	N2xØ2	O	O6	P	Q
MTRM 220	210	288	255	4x4	4x8	17	115	13,5	40
MTRM 250	210	282	255	8x8	8x12	17	165	13,5	40
MTRM 280	284	347	324	8x8	8x12	23	191	18	50
MTRM 310	407	485	400	8x10	10x12	23	212	18	60

Model	J	K	M	N1xØ1	N2xØ2	O	O6	P	Q
MTRM 350	407	485	400	8x12	10x12	28	234	22,5	80
MTRM 400	407	485	400	8x12	10x12	28	261	22,5	80
MTRM 450	407	485	400	8x12	10x12	28	289	22,5	80
MTRM 500	477	560	418	8x12	14x12	33	317	27	110

Model	R	S	S1	S2	S3	S4	S5	S6	S7
MTRM 220	17	226	175	190	165	280	232	200	190
MTRM 250	17	276	212	215	195	360	314	255	235
MTRM 280	23	305	231	226	200	391	353	287	262
MTRM 310	28	332	256	253	225	437	393	316	288
MTRM 350	28	375	288	278	255	489	437	359	325
MTRM 400	28	400	311	306	285	543	487	387	353
MTRM 450	28	445	354	342	320	609	542	435	398
MTRM 500	33	502	400	380	360	676	597	490	450

Model	T	T1	U	V	V1	W	X	X1	X2
MTRM 220	6	6	80	19	19	61	175	165	280
MTRM 250	6	6	80	19	19	55	212	195	360
MTRM 280	8	8	100	24	24	40	231	200	391
MTRM 310	8	8	100	28	24	40	256	225	437
MTRM 350	10	8	120	38	28	50	288	255	489
MTRM 400	10	10	120	38	38	50	311	285	543
MTRM 450	10	10	120	38	38	50	354	320	609
MTRM 500	12	12	140	42	42	50	400	360	677

Model	X3	X4	X5	X6	X7	a	a1	a2	b
MTRM 220	232	200	226	190	190	124	145	164	103
MTRM 250	314	255	276	235	215	207	241	277	148
MTRM 280	353	287	305	262	226	231	265	301	166
MTRM 310	393	316	332	288	253	288	332	368	205
MTRM 350	437	359	375	325	278	322	366	402	229
MTRM 400	487	387	400	353	306	322	366	402	229
MTRM 450	542	435	445	398	342	361	405	441	256
MTRM 500	597	490	502	450	380	404	448	484	288

Model	b1	b2	d	d1	d2	n1xp	n2xp	Ø3	Ø4
MTRM 220	125	143	130	165	190	-	-	10	12
MTRM 250	182	218	185	219	250	1x112	1x112	10	12
MTRM 280	200	236	205	241	275	1x112	1x112	12	15
MTRM 310	249	285	255	292	325	1x125	2x125	12	15

Model	b1	b2	d	d1	d2	n1xp	n2xp	Ø3	Ø4
MTRM 350	273	309	285	332	365	1x125	2x125	14	15
MTRM 400	273	309	285	332	365	1x125	2x125	14	15
MTRM 450	300	336	320	366	400	1x125	2x125	14	15
MTRM 500	332	368	360	405	440	2x125	3x125	17	18

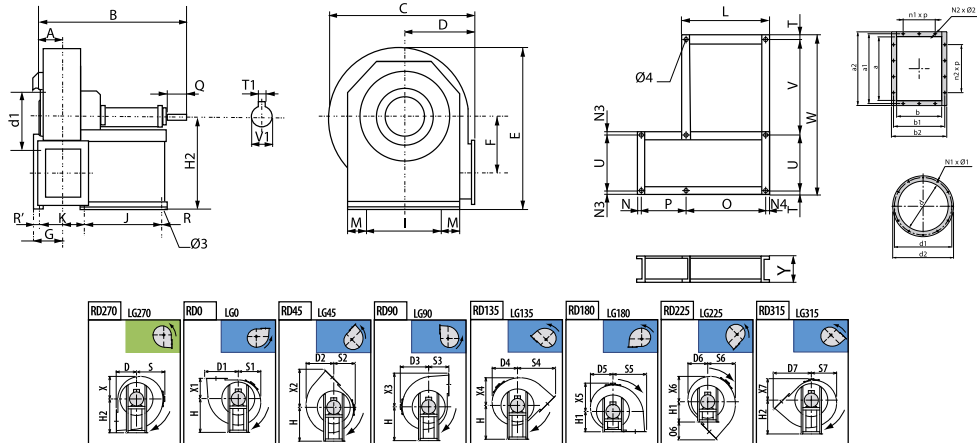

Model	A	B	C	D	D1	D2	D3	D4	D5
MTRM 560	177	1058	970	400	657	555	570	542	485
MTRM 630	195	1102	1080	450	733	619	630	603	550

Model	D6	D7	E	F	G	H	H1	H2	I
MTRM 560	425	747	1155	390	214	670	400	670	632
MTRM 630	476	836	439	1300	234	750	450	750	702

Model	J	K	L	M	N	N1xØ1	N2xØ2	N3	N4
MTRM 560	477	943	543	30	23	12x12	14x12	30	33
MTRM 630	477	983	543	30	23	12x12	14x12	30	33

Model	O	O6	P	Q	R	S	S1	S2	S3
MTRM 560	477	347	410	110	33	570	485	425	400
MTRM 630	477	386	450	110	33	630	550	476	450

Model	S4	S5	S6	S7	T	U	V	W	X
MTRM 560	747	667	555	542	14	632	678	1370	485
MTRM 630	836	733	619	603	14	702	708	1470	550

Model	X1	X2	X3	X4	X5	X6	X7	Y	a

Model	X1	X2	X3	X4	X5	X6	X7	Y	a
MTRM 560	400	747	657	555	570	542	425	160	453
MTRM 630	450	836	733	619	630	603	476	160	507

Model	a1	a2	b	b1	b2	d	d1	d2	n1xp
MTRM 560	497	533	361	405	441	405	448	485	2x125
MTRM 630	551	587	361	405	441	455	497	535	2x125

Model	n2xp	Ø3	Ø4
MTRM 560	3x125	17	18
MTRM 630	3x125	17	18

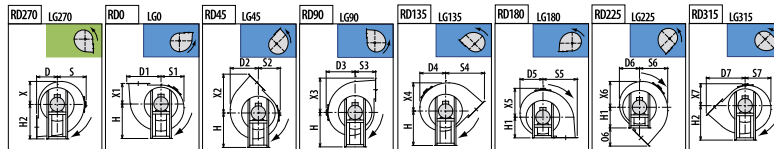
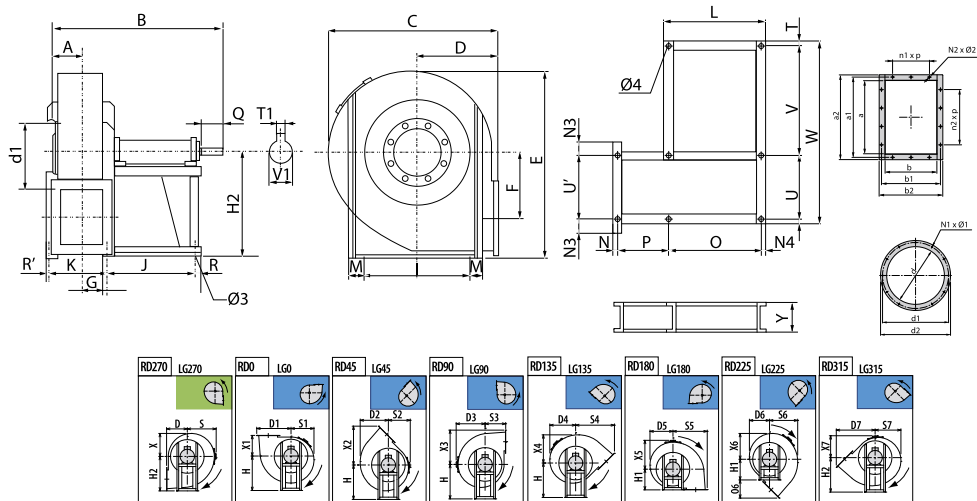

Model	A	B	C	D	D1	D2	D3	D4	D5
MTRM 710	216	1241	1190	500	835	719	690	662	565
MTRM 800	241	1306	1342	560	929	811	782	749	641
MTRM 900	275	1360	1500	630	1038	905	870	835	721
MTRM 1000	308	1565	1686	710	1171	1015	976	936	814
MTRM 1120	350	1780	1884	800	1309	1133	1084	1037	932
MTRM 1250	388	1855	2114	900	1464	1270	1214	1163	1048
MTRM 1400	442	2050	2325	1000	1635	1395	1325	1272	1145
MTRM 1600	490	2358	2620	1120	1824	1572	1500	1434	1276
MTRM 1800	654	2525	2960	1250	2025	1790	1710	1610	1471
MTRM 2000	715	2645	3290	1400	2271	1970	1890	1811	1635

Model	D6	D7	E	F	G	H	H1	H2	I
MTRM 710	497	944	1415	500	262	670	500	670	772

Model	D6	D7	E	F	G	H	H1	H2	I
MTRM 800	562	1053	1591	560	307	755	560	755	862
MTRM 900	633	1180	1781	630	334	850	630	850	962
MTRM 1000	718	1330	1994	710	385	950	710	950	1056
MTRM 1120	793	1491	2252	800	419	1060	800	1060	1178
MTRM 1250	898	1671	2548	900	458	1190	900	1190	1310
MTRM 1400	990	1863	2845	1000	531	1320	1000	1320	1450
MTRM 1600	1085	2081	3176	1120	579	1500	1120	1500	1640
MTRM 1800	1300	2312	3591	1244	634	1650	1250	1650	1830
MTRM 2000	1455	2595	3995	1394	715	1850	1400	1850	2030

Model	J	K	L	M	N	N1xØ1	N2xØ2	N3	N4
MTRM 710	551	497	629	71	27	12x14	14x14	71	39
MTRM 800	551	546	629	91	39	12x14	14x14	91	39
MTRM 900	551	600	629	91	39	12x14	16x14	91	39
MTRM 1000	607	657	697	99	67	16x14	14x14	99	45
MTRM 1120	760	763	850	111	55	16x14	18x14	111	45
MTRM 1250	760	840	850	110	55	16x14	18x14	110	45
MTRM 1400	780	946	890	120	85	24x14	20x18	120	55
MTRM 1600	917	1073	1047	120	75	24x14	24x18	120	65
MTRM 1800	917	1193	1047	130	65	24x17	24x18	130	65
MTRM 2000	917	1315	1047	170	85	32x17	28x22	170	65

Model	O	O6	P	Q	R	R'	S	S1	S2
MTRM 710	551	444	497	110	39	27	690	565	497
MTRM 800	551	493	546	110	39	47	782	641	562
MTRM 900	551	550	600	110	39	47	870	721	633
MTRM 1000	657	620	607	140	45	67	976	814	718
MTRM 1120	760	691	763	140	45	55	1084	932	793
MTRM 1250	760	771	840	140	45	55	1214	1048	898
MTRM 1400	780	863	946	170	55	85	1325	1145	990
MTRM 1600	917	961	1073	210	65	75	1500	1276	1085
MTRM 1800	917	1062	1193	210	65	65	1710	1471	1300
MTRM 2000	917	1195	1315	210	65	85	1890	1635	1455

Model	S3	S4	S5	S6	S7	T	U	U'	V
MTRM 710	500	944	835	719	662	14	772	772	807
MTRM 800	560	1053	929	811	749	32	862	862	842
MTRM 900	630	1180	1038	905	835	32	962	962	987
MTRM 1000	710	1330	1171	1015	936	18	1056	1056	1036
MTRM 1120	800	1491	1309	1133	1037	20	1178	1178	1066

Model	S3	S4	S5	S6	S7	T	U	U'	V
MTRM 1250	900	1671	1464	1270	1163	20	1310	1310	1230
MTRM 1400	1000	1863	1635	1395	1272	22	1450	1450	1240
MTRM 1600	1120	2081	1824	1572	1434	25	1640	1640	1205
MTRM 1800	1250	2312	2025	1790	1610	28	1830	1830	1385
MTRM 2000	1400	2595	2271	1970	1811	28	2030	1830	1350

Model	V1	W	X	X1	X2	X3	X4	X5	X6
MTRM 710	48	1633	565	500	944	835	719	690	662
MTRM 800	55	1768	641	560	1053	929	811	782	749
MTRM 900	55	2013	721	630	1180	1038	905	870	835
MTRM 1000	65	2164	814	710	1330	1171	1015	976	936
MTRM 1120	75	2334	932	800	1491	1309	1133	1084	1037
MTRM 1250	75	2630	1048	900	1671	1464	1270	1214	1163
MTRM 1400	80	2800	1145	1000	1863	1635	1395	1325	1272
MTRM 1600	90	2965	1276	1120	2081	1824	1572	1500	1434
MTRM 1800	100	3335	1471	1250	2312	2025	1790	1710	1610
MTRM 2000	100	3500	1635	1400	2595	2271	1970	1890	1811

Model	X7	Y	a	a1	a2	b	b1	b2	d
MTRM 710	497	180	569	629	669	404	464	504	505
MTRM 800	562	180	638	698	738	453	513	553	565
MTRM 900	633	180	715	775	815	507	567	607	635
MTRM 1000	718	200	801	871	921	569	639	689	715
MTRM 1120	793	220	898	968	1018	638	708	758	805
MTRM 1250	898	220	1007	1077	1127	715	785	835	905
MTRM 1400	990	220	1130	1210	1270	801	881	941	1007
MTRM 1600	1085	220	1276	1347	1407	898	978	1038	1130
MTRM 1800	1300	250	1421	1501	1561	1007	1087	1147	1260
MTRM 2000	1455	250	1593	1683	1753	1130	1220	1290	1420

Model	d1	d2	n1xp	n2xp	Ø3	Ø4
MTRM 710	551	585	2x160	3x160	19	20
MTRM 800	629	665	2x160	3x160	19	20
MTRM 900	698	735	2x160	4x160	19	20
MTRM 1000	775	815	2x200	3x200	19	20
MTRM 1120	861	905	3x200	4x200	24	25
MTRM 1250	958	1005	3x200	4x200	24	25
MTRM 1400	1067	1107	3x200	5x200	24	25
MTRM 1600	1200	1250	4x200	6x200	28	30
MTRM 1800	1337	1380	4x200	6x200	28	30

Model	d1	d2	n1xp	n2xp	Ø3	Ø4
MTRM 2000	1491	1540	5x200	7x200	28	30

Wiring diagram

DIAGRAM Nº 1

230/400V

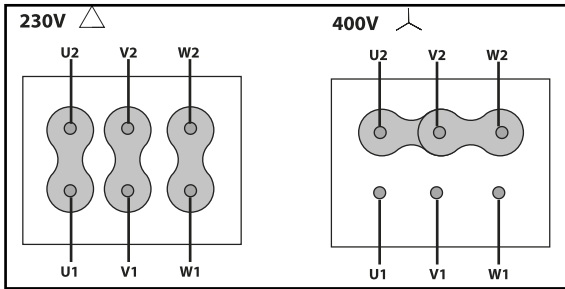

400/690V

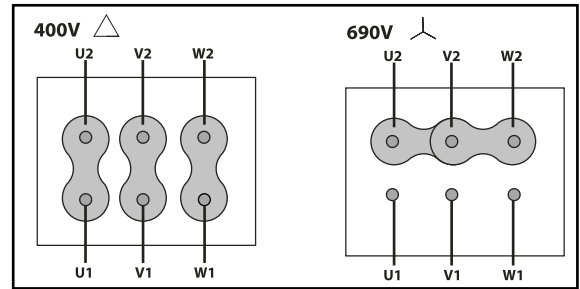

CHARACTERISTIC CURVE

MTRM 220

AIR FLOW - PRESSURE

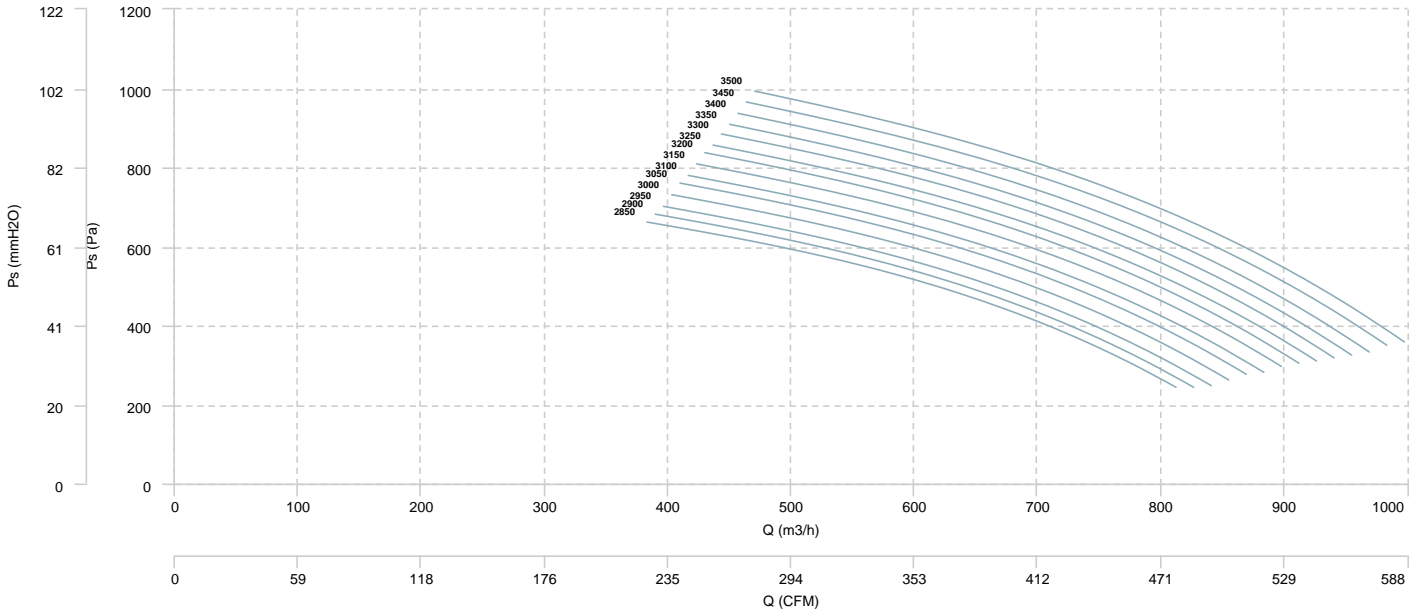

AIR FLOW - MECHANICAL POWER

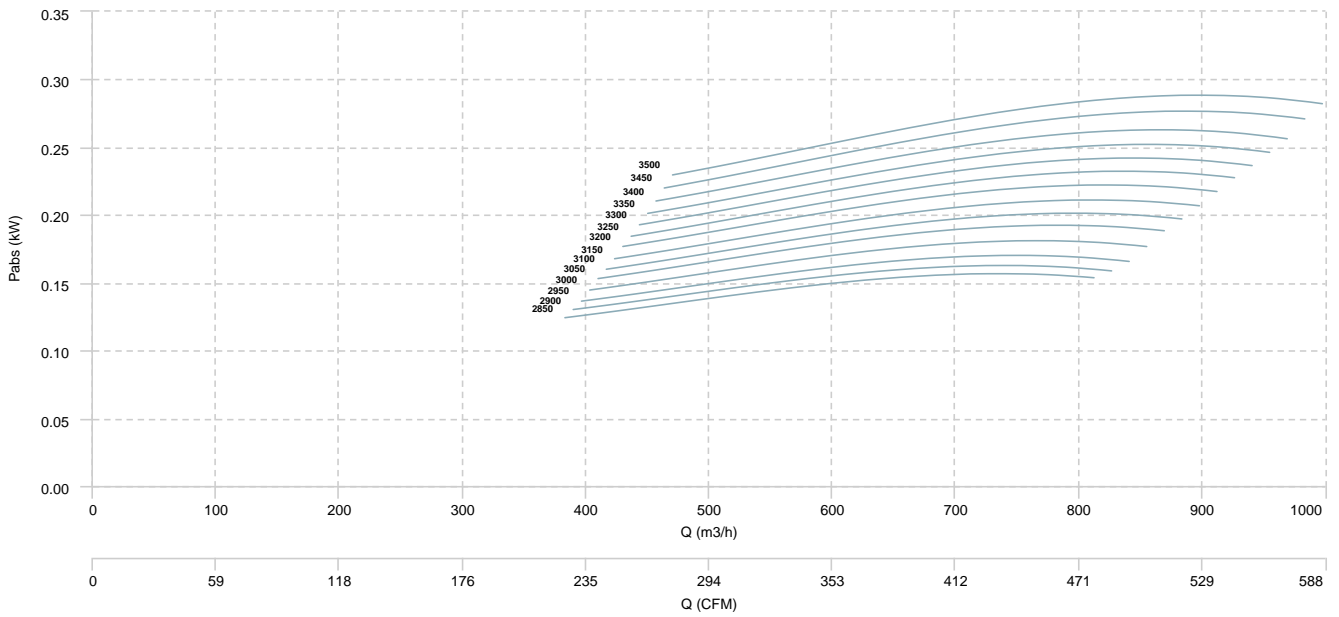

MTRM 250

AIR FLOW - PRESSURE

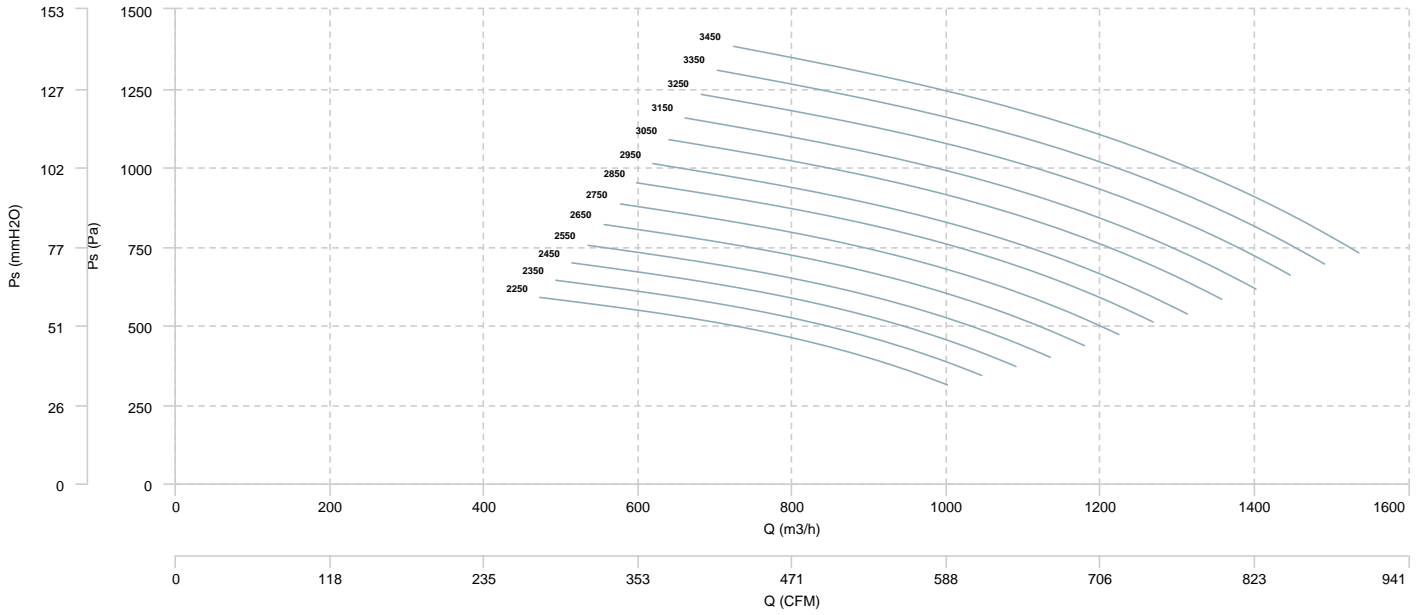

AIR FLOW - MECHANICAL POWER

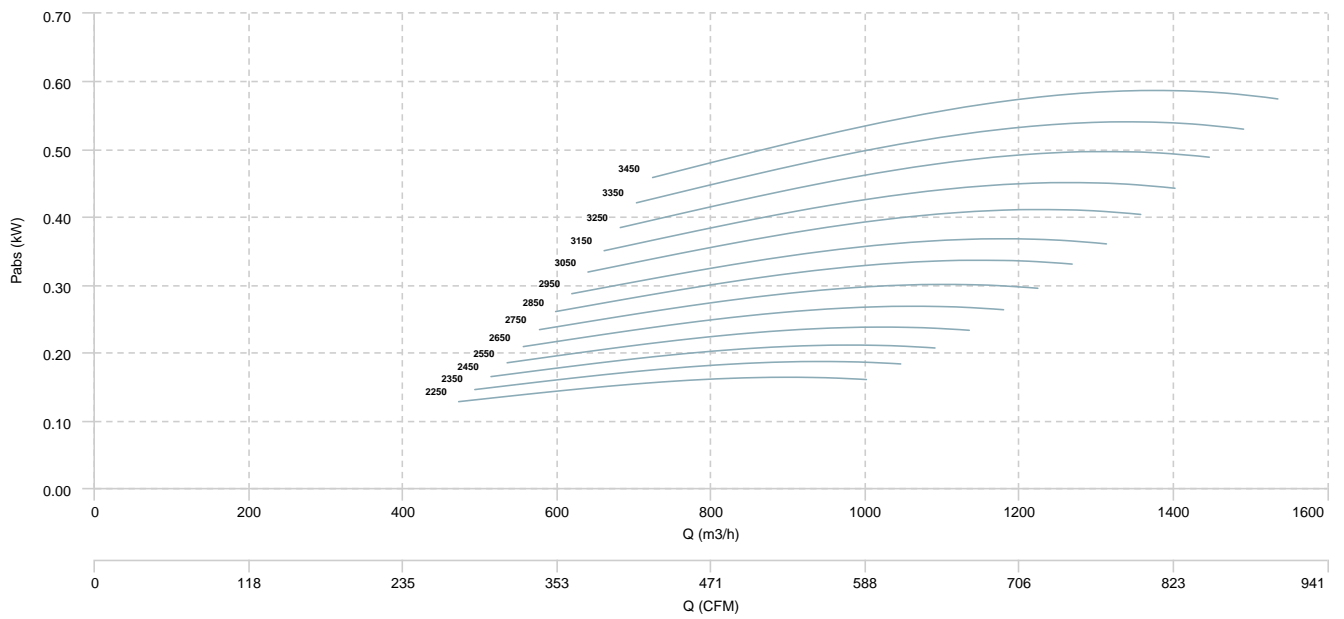

MTRM 280

AIR FLOW - PRESSURE

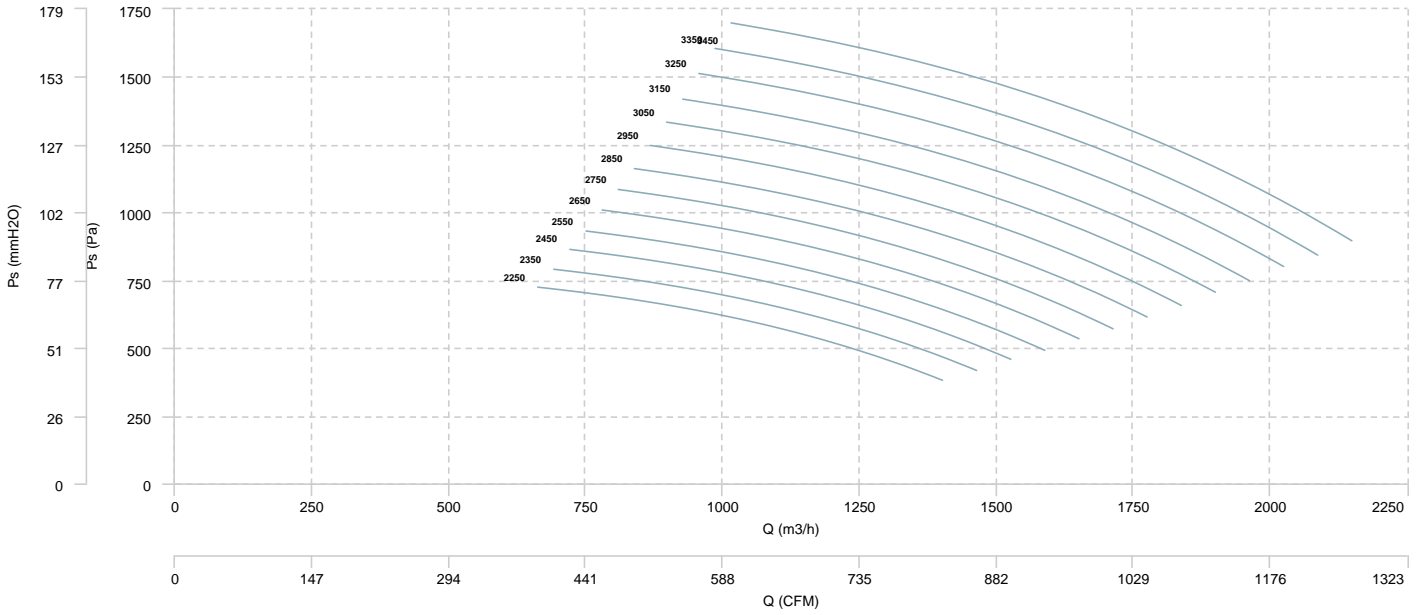

AIR FLOW - MECHANICAL POWER

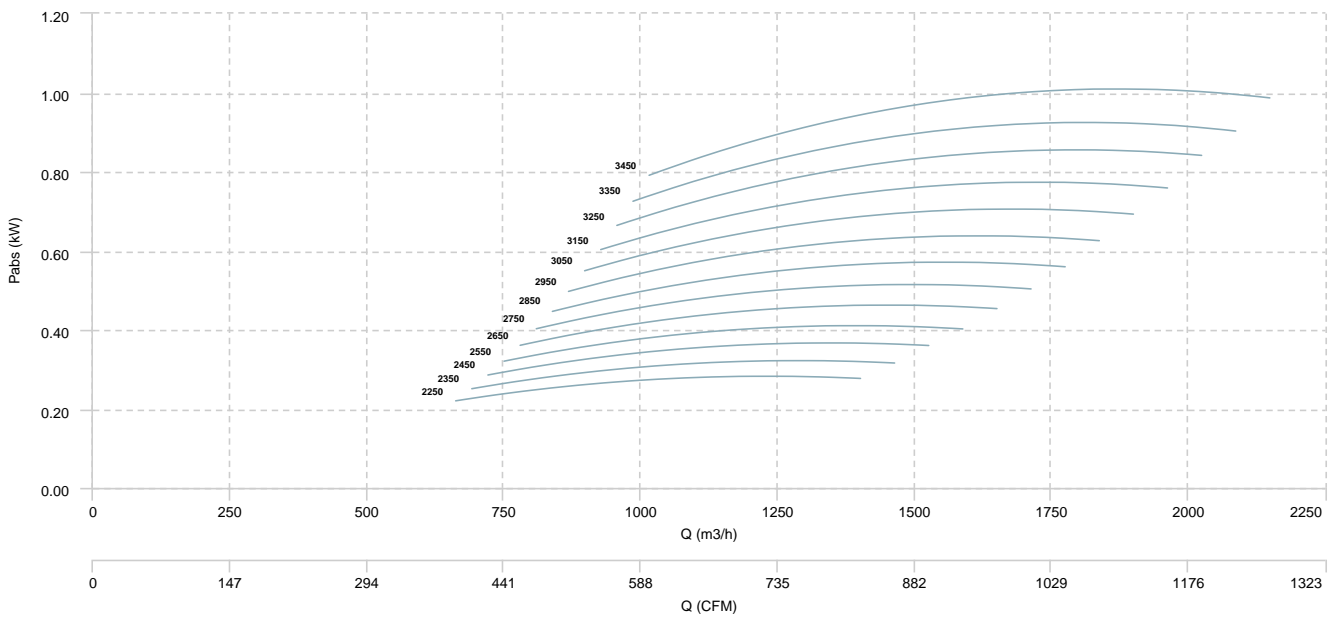

MTRM 310

AIR FLOW - PRESSURE

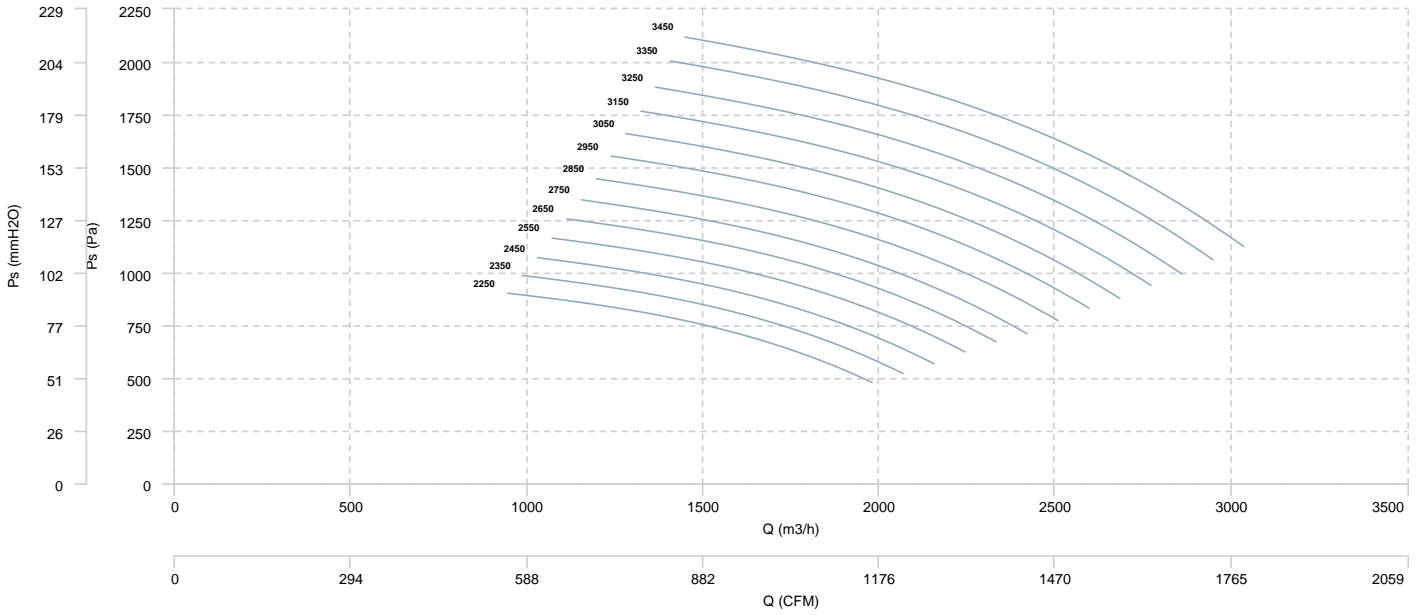

AIR FLOW - MECHANICAL POWER

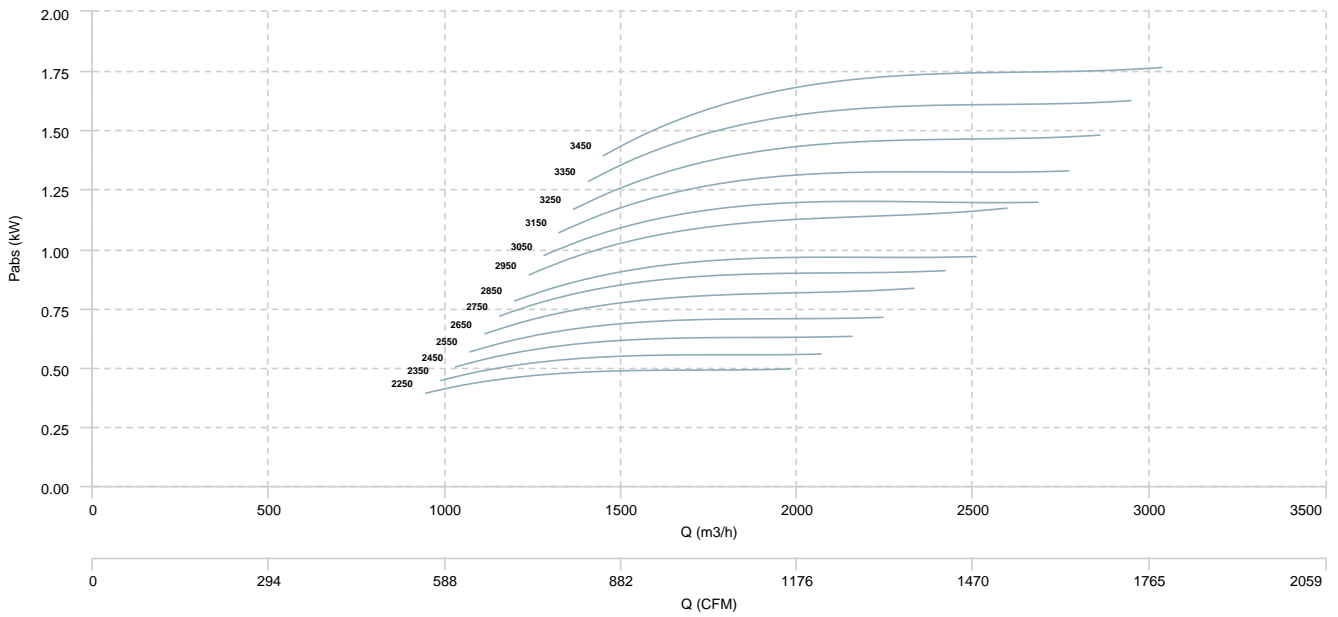

MTRM 350

AIR FLOW - PRESSURE

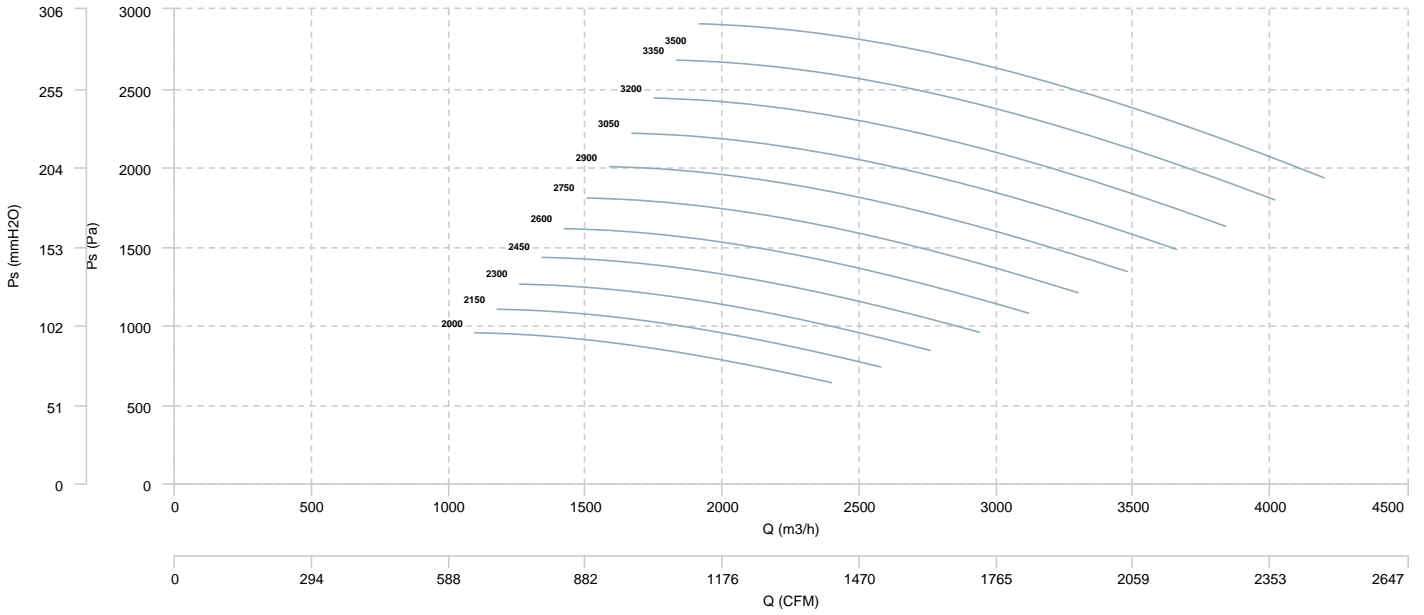

AIR FLOW - MECHANICAL POWER

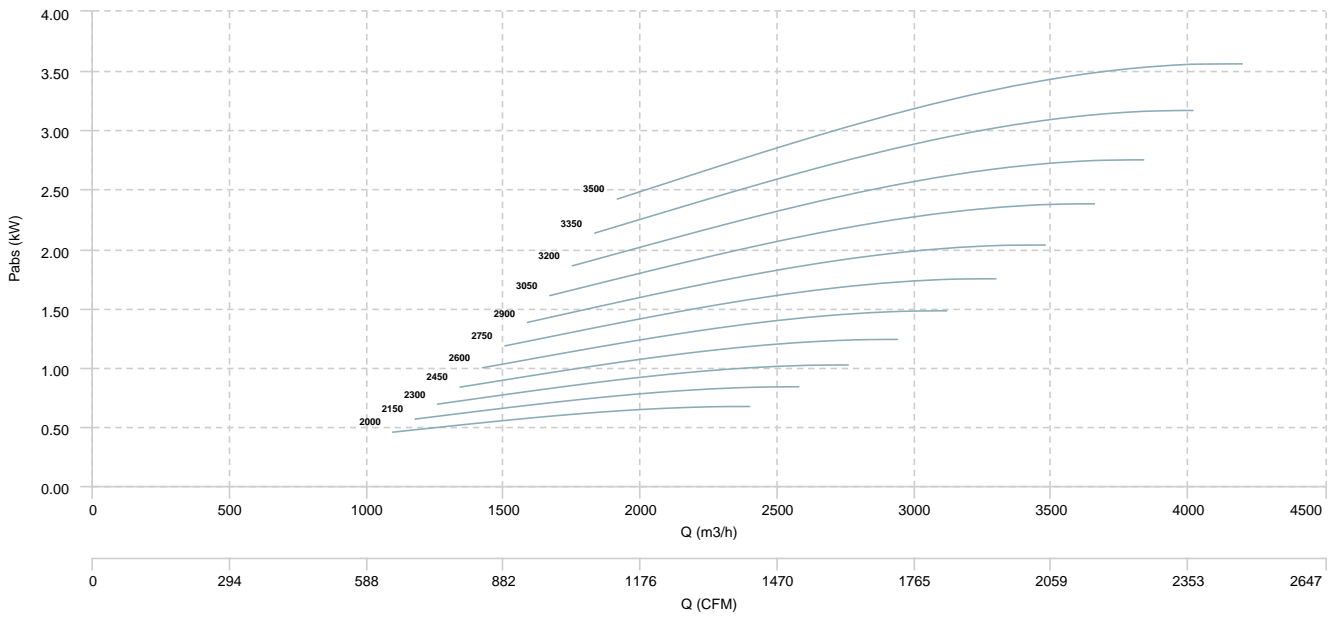

MTRM 400

AIR FLOW - PRESSURE

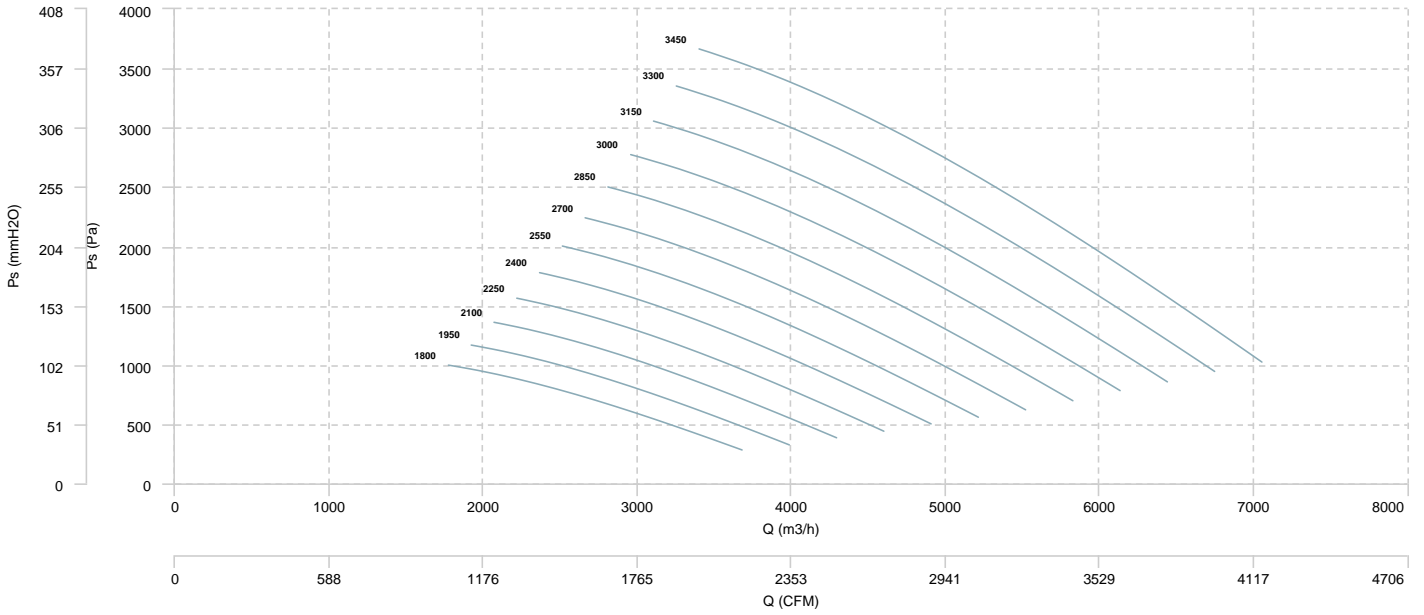

AIR FLOW - MECHANICAL POWER

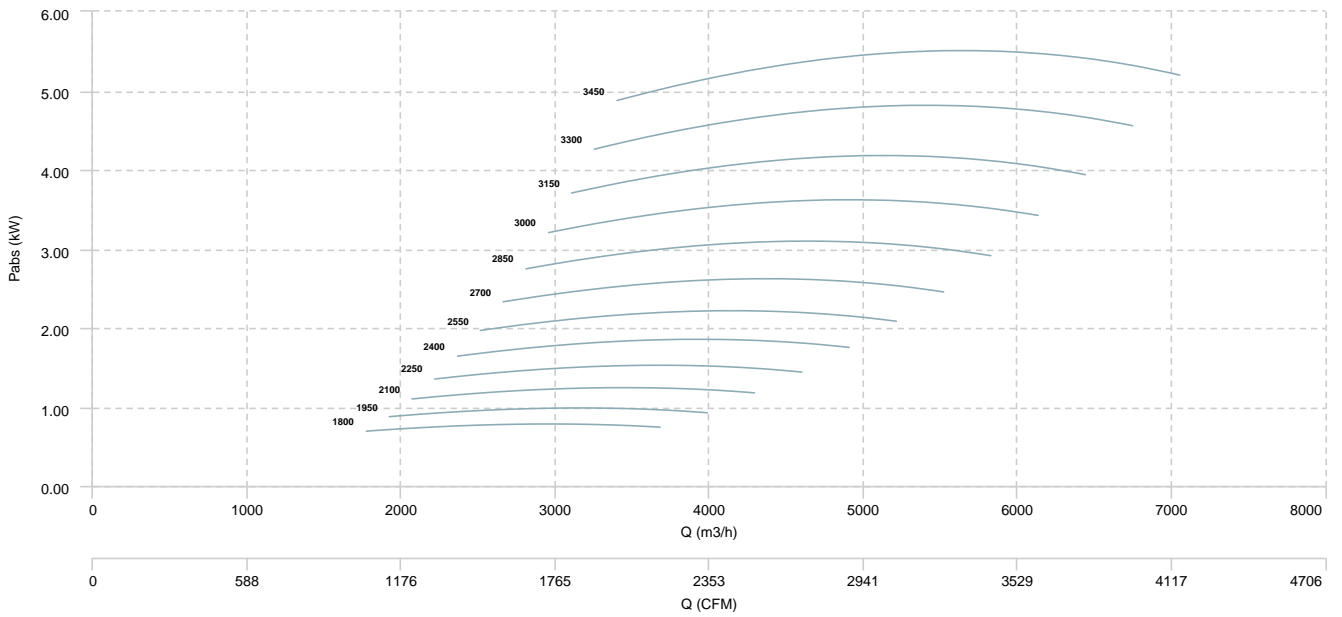

MTRM 450

AIR FLOW - PRESSURE

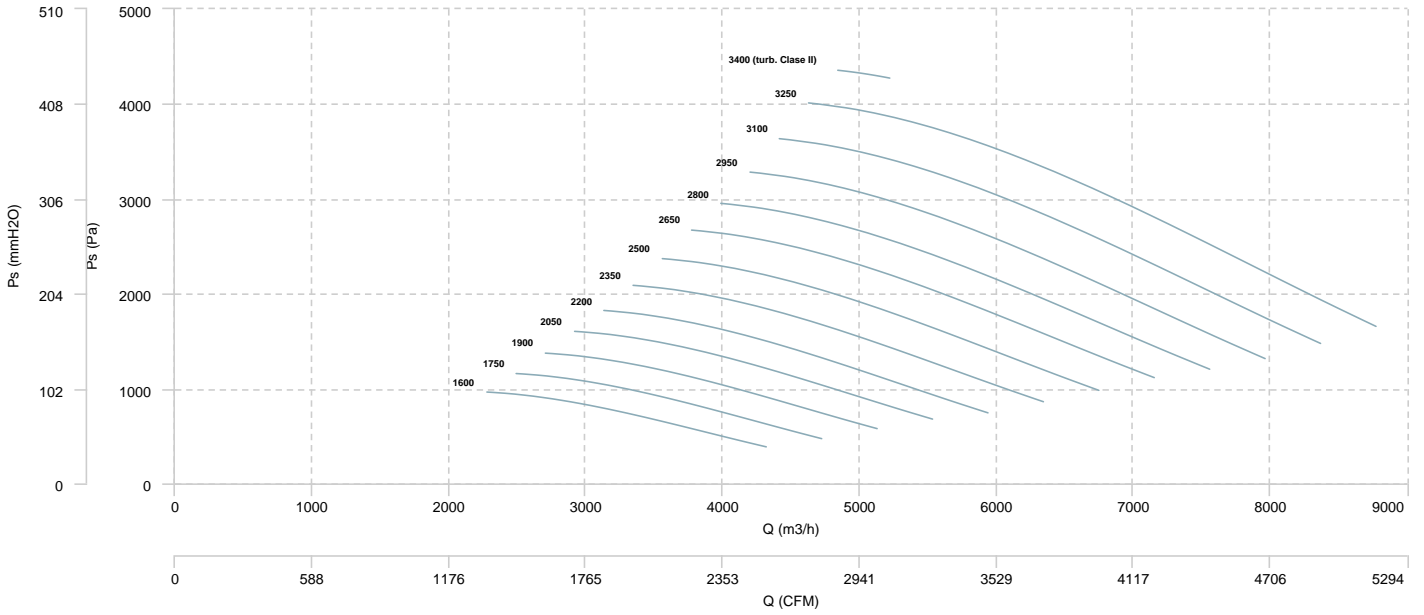

AIR FLOW - MECHANICAL POWER

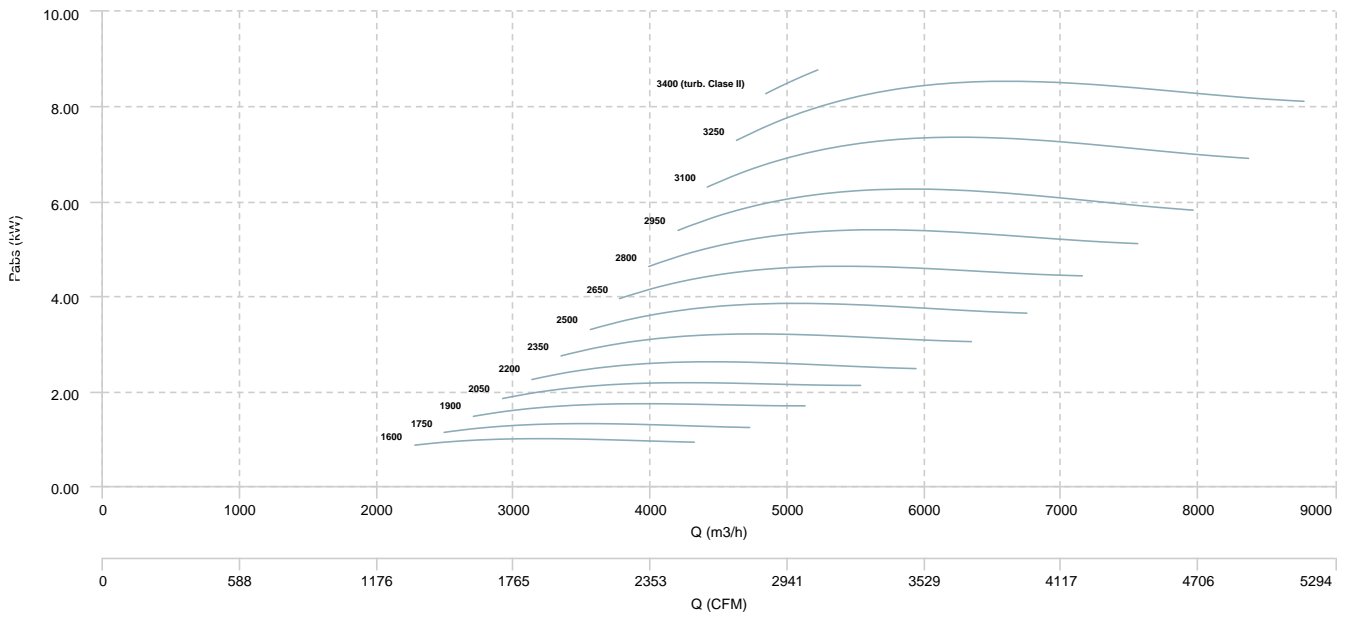

MTRM 500

AIR FLOW - PRESSURE

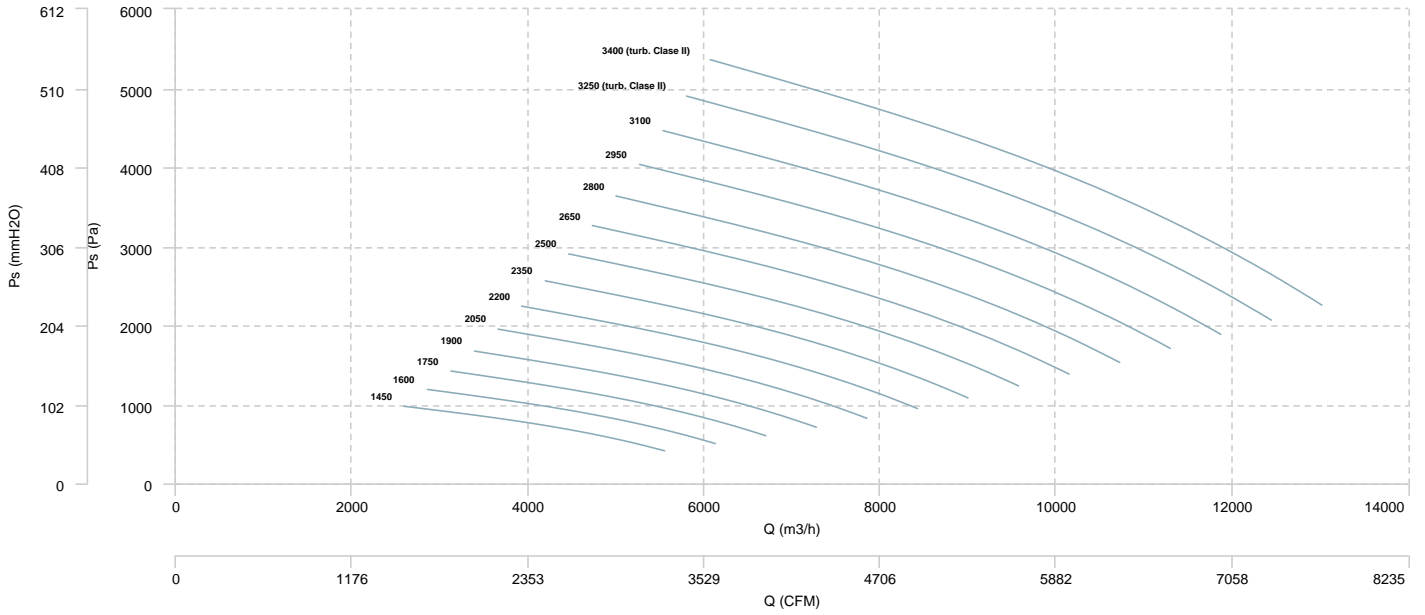

AIR FLOW - MECHANICAL POWER

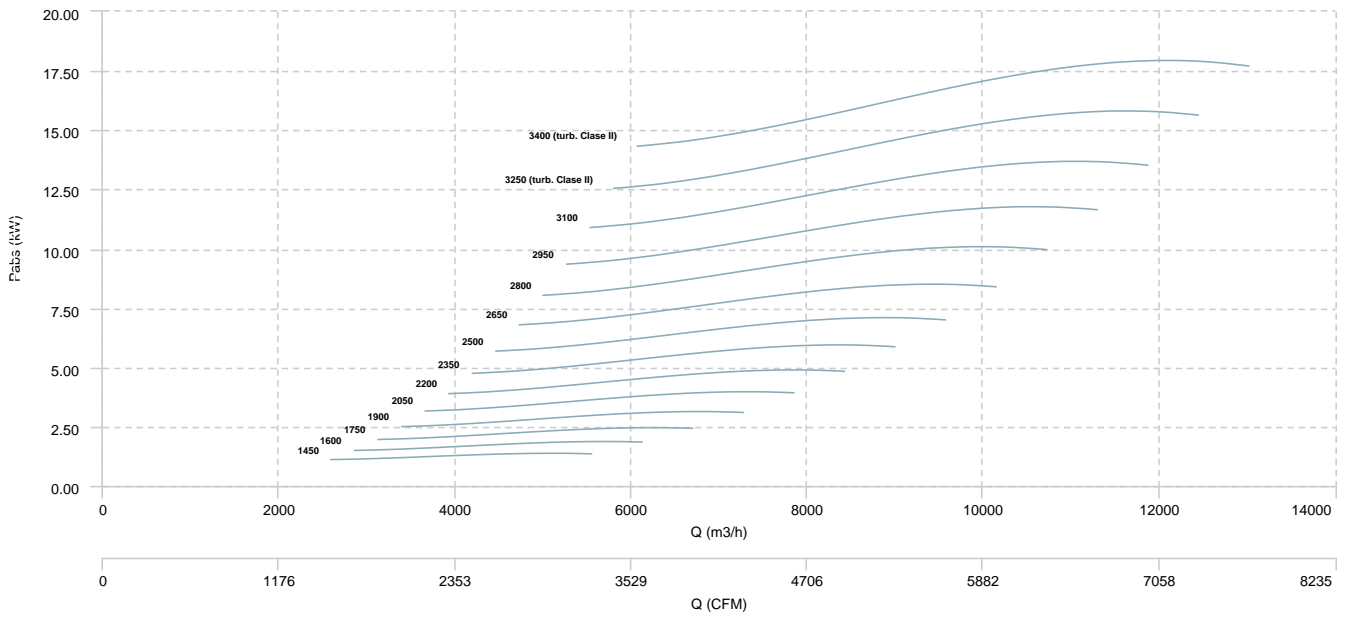

MTRM 560

AIR FLOW - PRESSURE

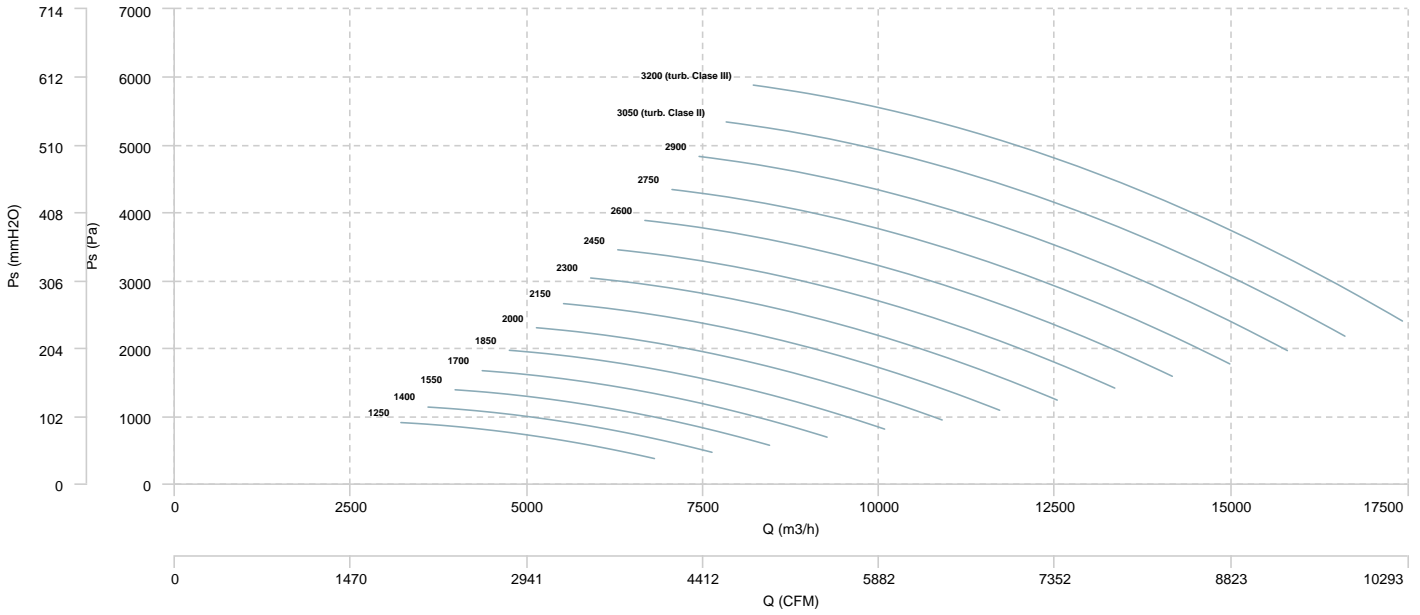

AIR FLOW - MECHANICAL POWER

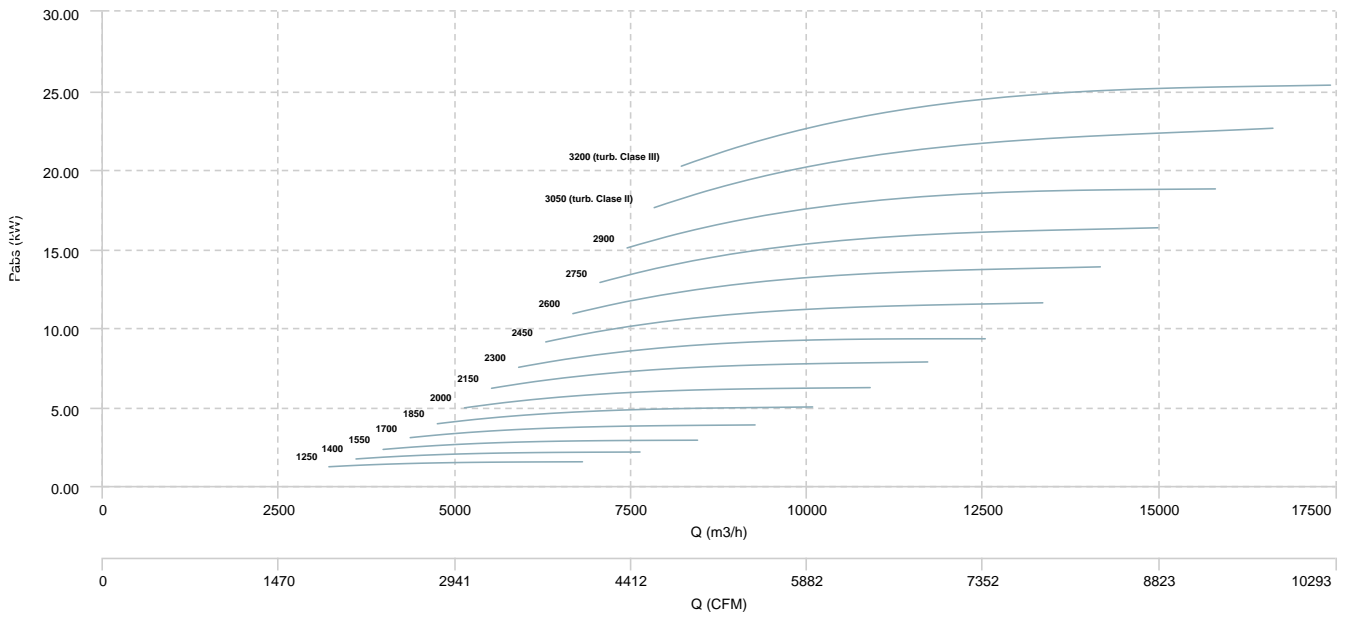

MTRM 630

AIR FLOW - PRESSURE

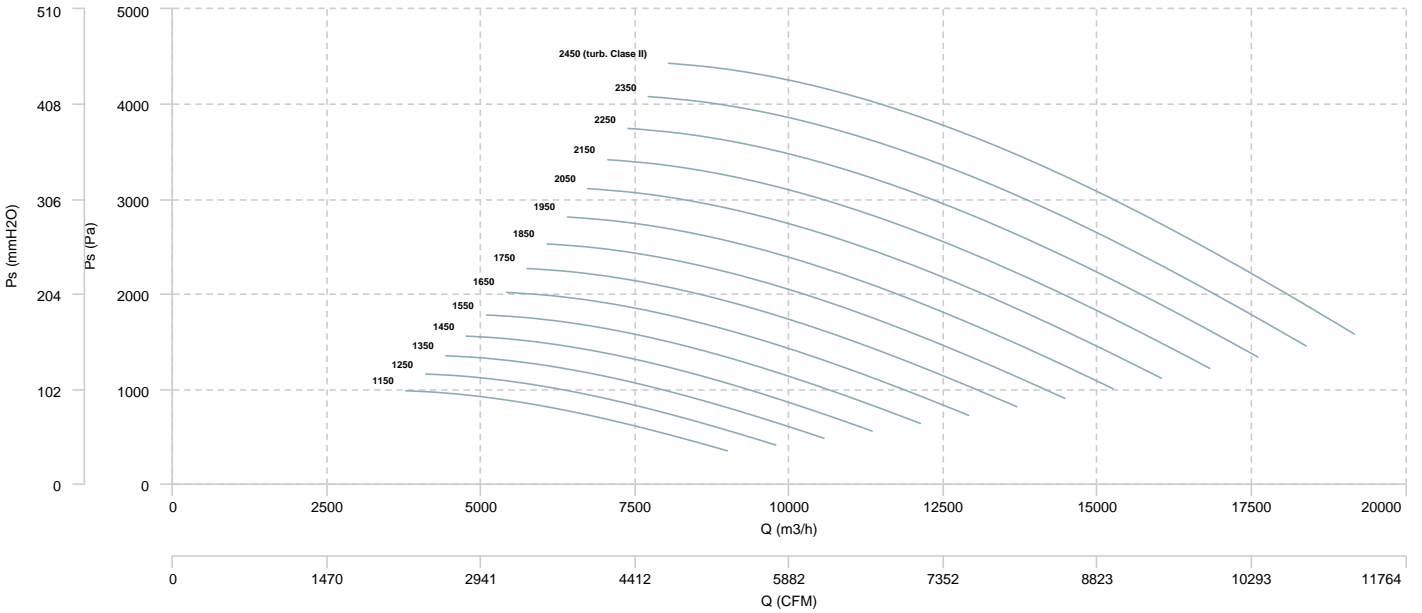

AIR FLOW - MECHANICAL POWER

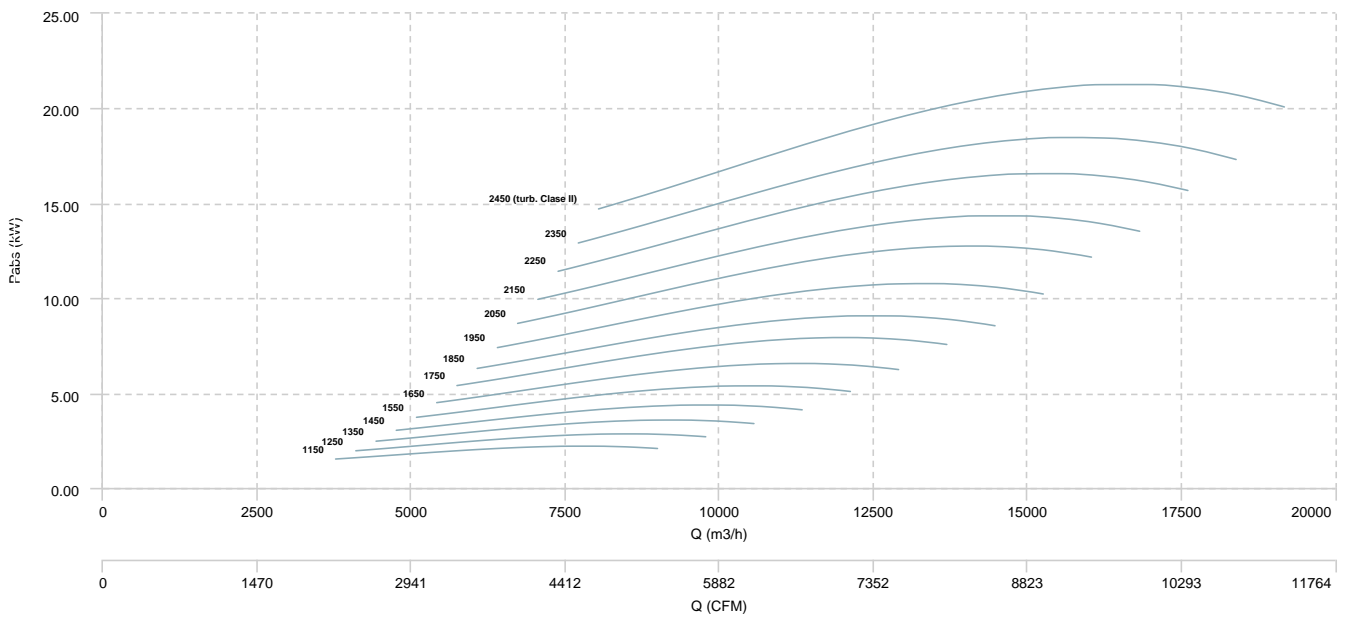

MTRM 710

AIR FLOW - PRESSURE

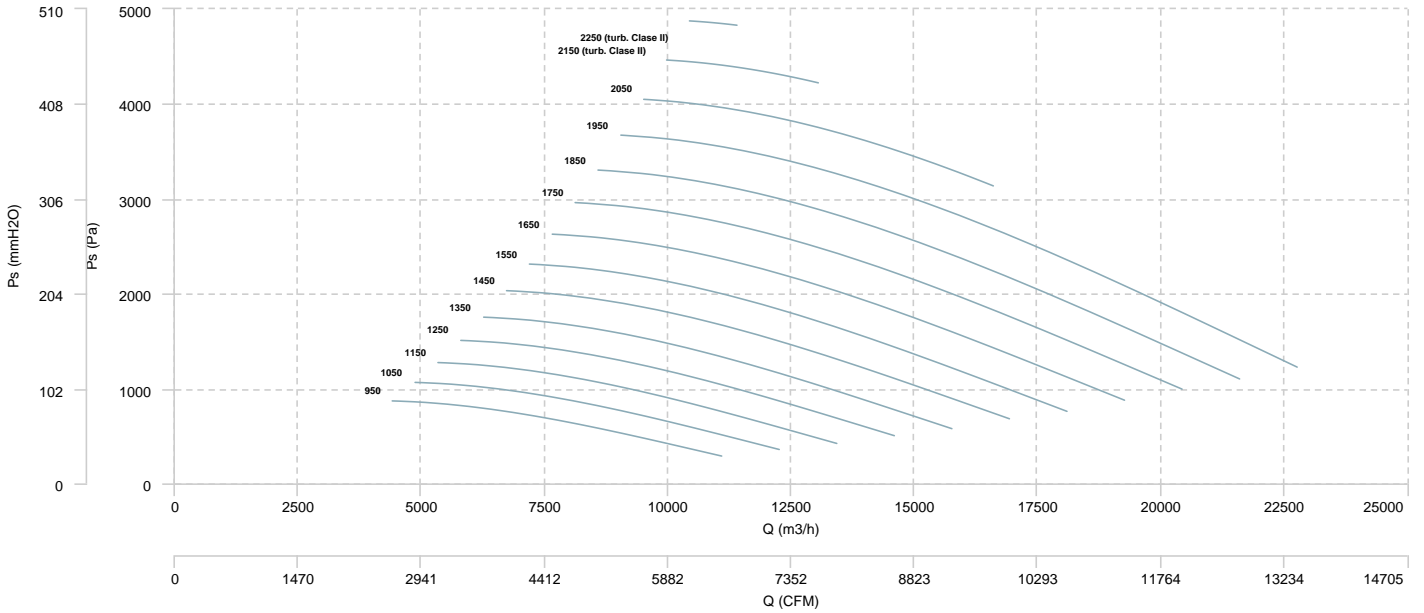

AIR FLOW - MECHANICAL POWER

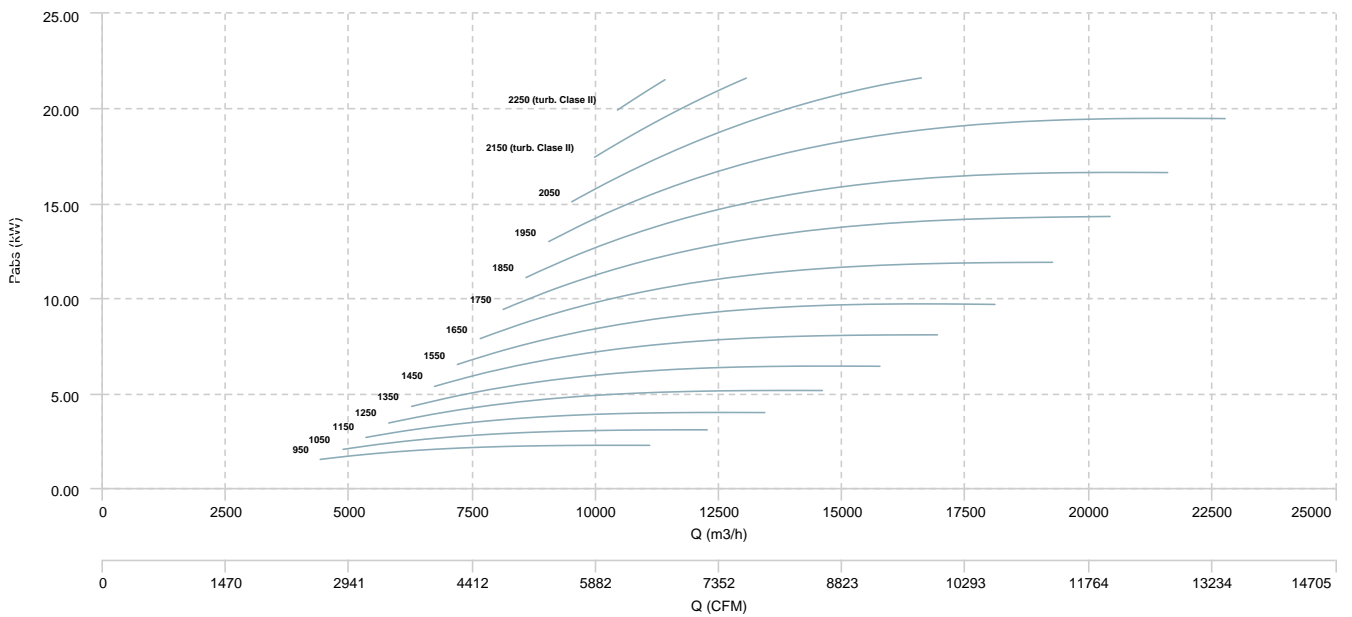

MTRM 800

AIR FLOW - PRESSURE

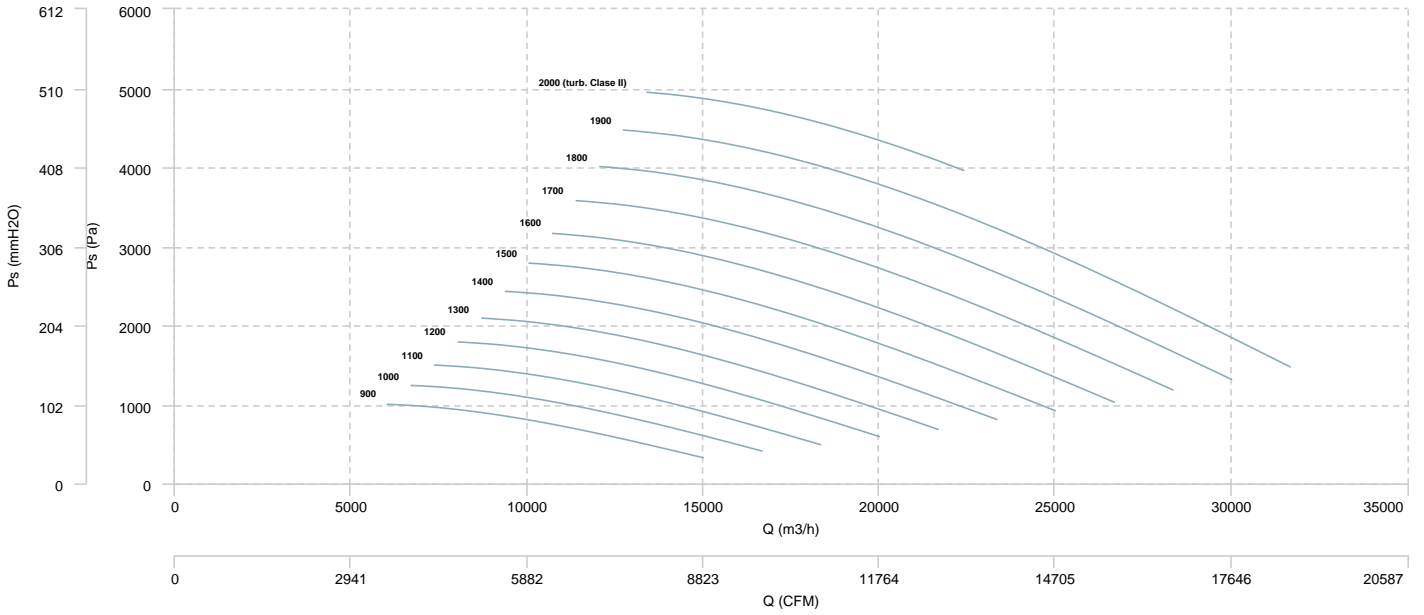

AIR FLOW - MECHANICAL POWER

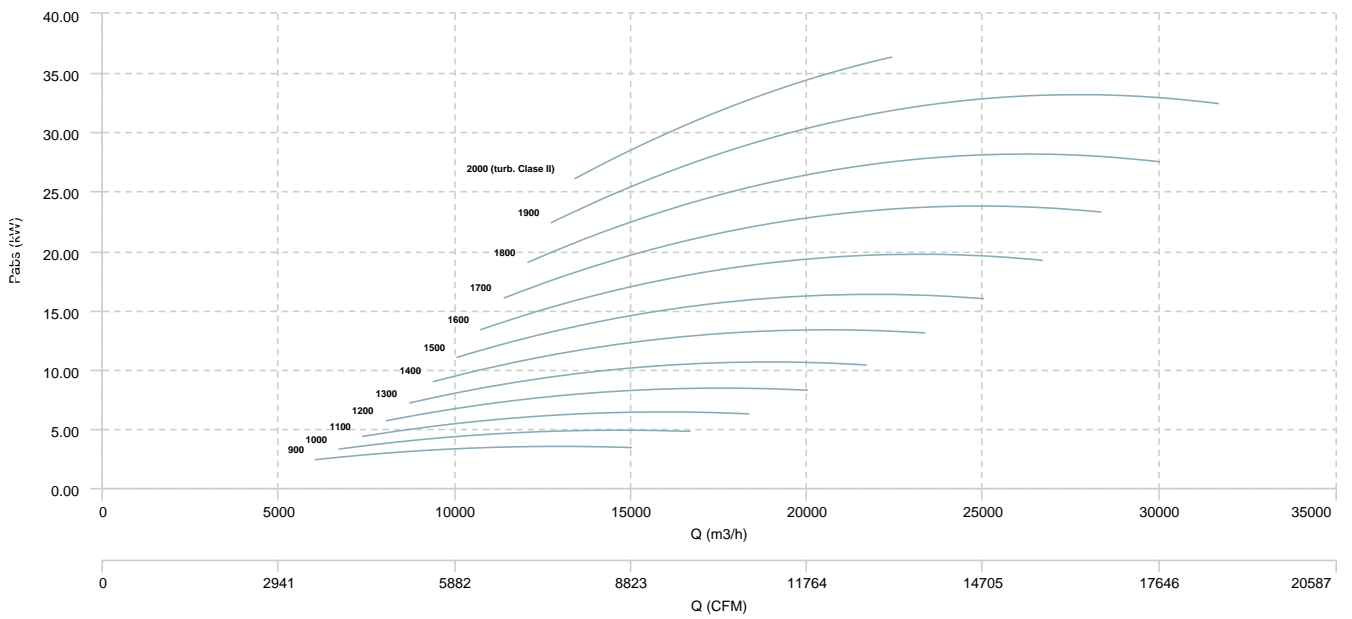

MTRM 900

AIR FLOW - PRESSURE

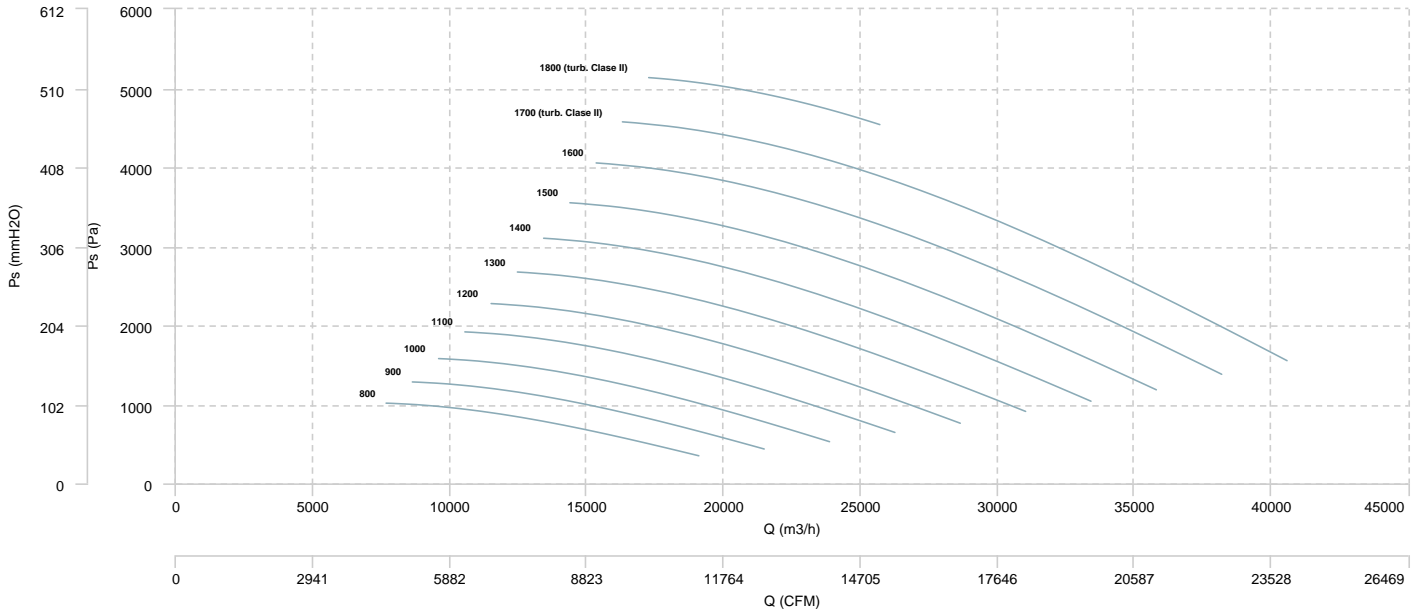

AIR FLOW - MECHANICAL POWER

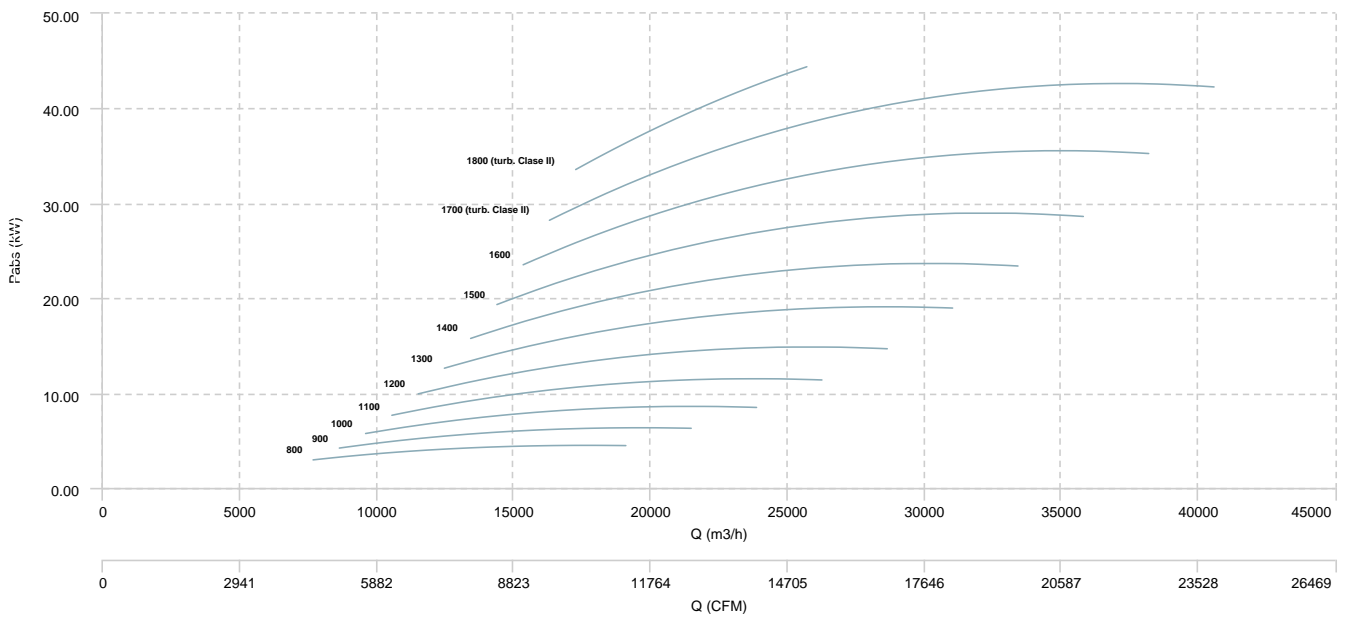

MTRM 1000

AIR FLOW - PRESSURE

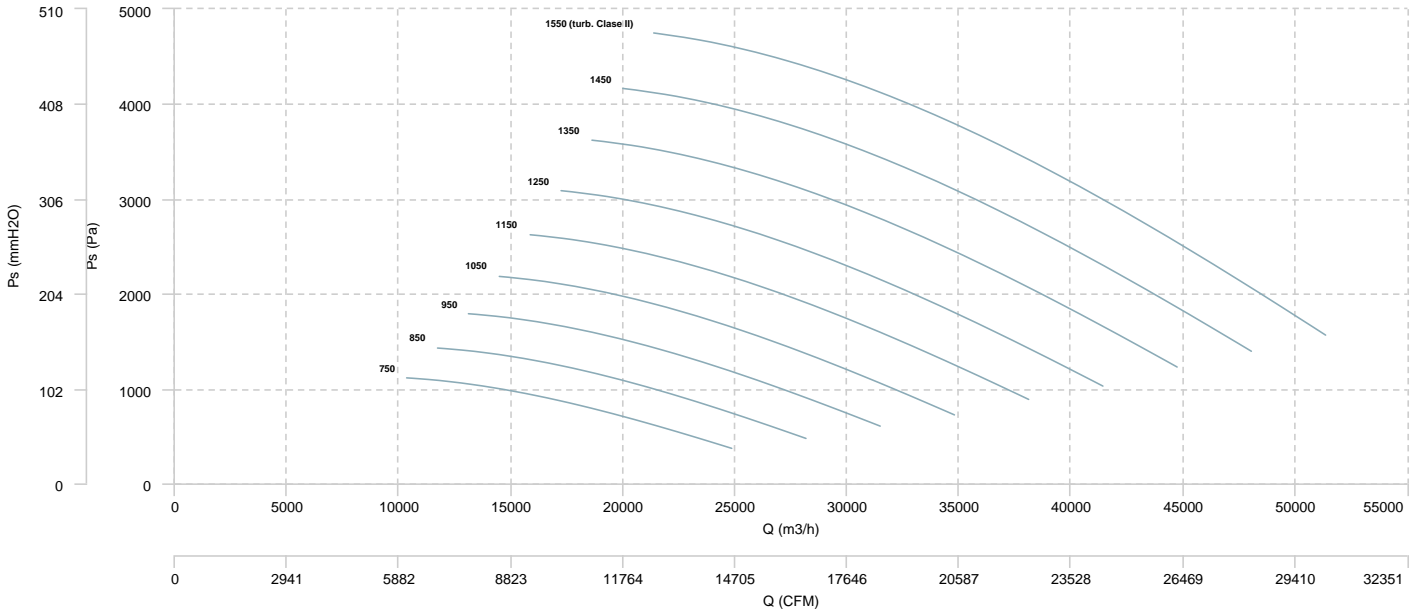

AIR FLOW - MECHANICAL POWER

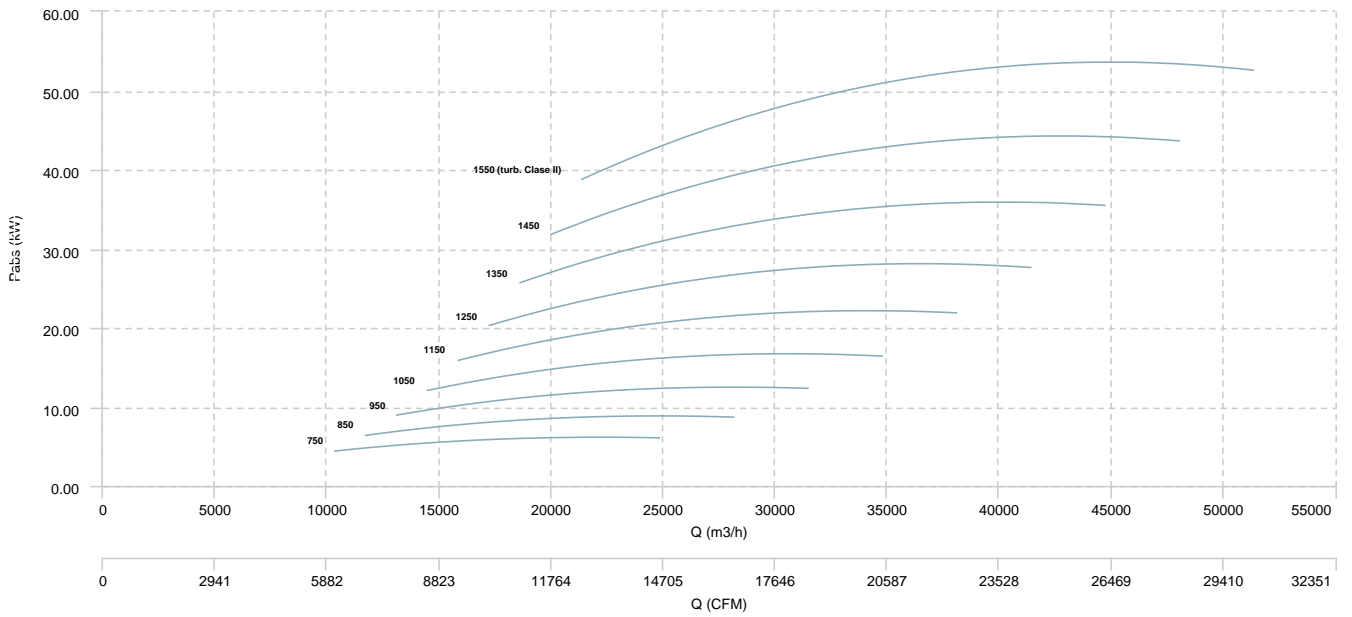

MTRM 1120

AIR FLOW - PRESSURE

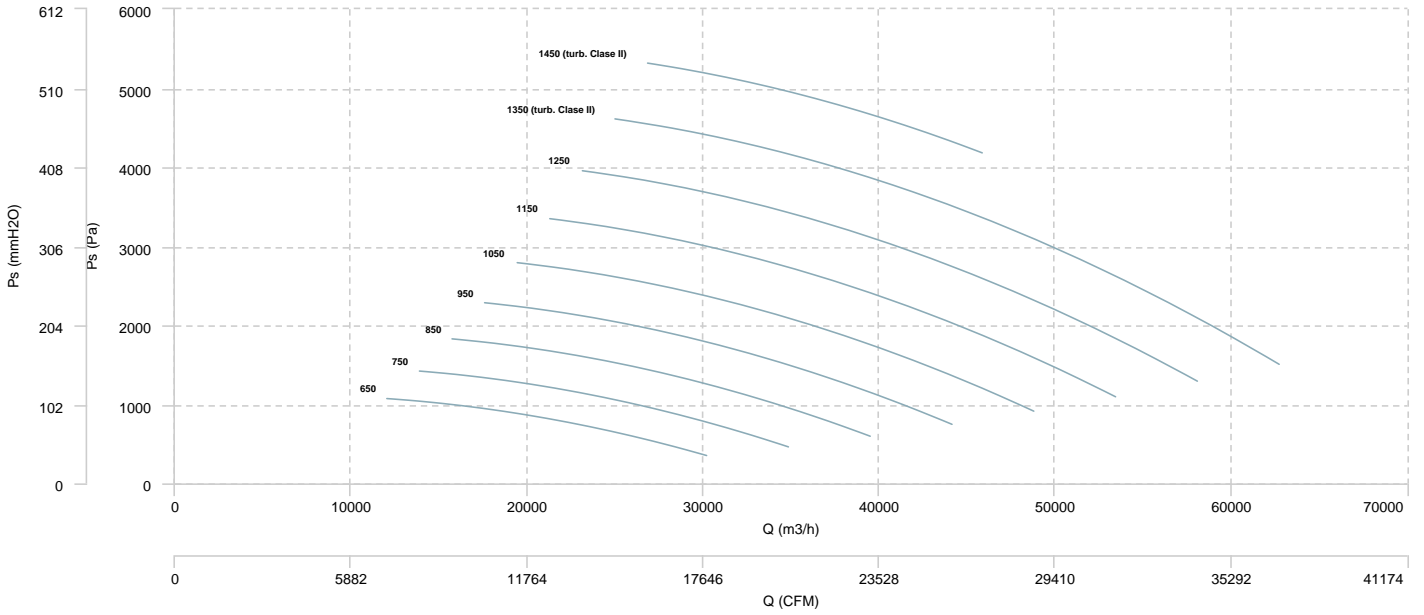

AIR FLOW - MECHANICAL POWER

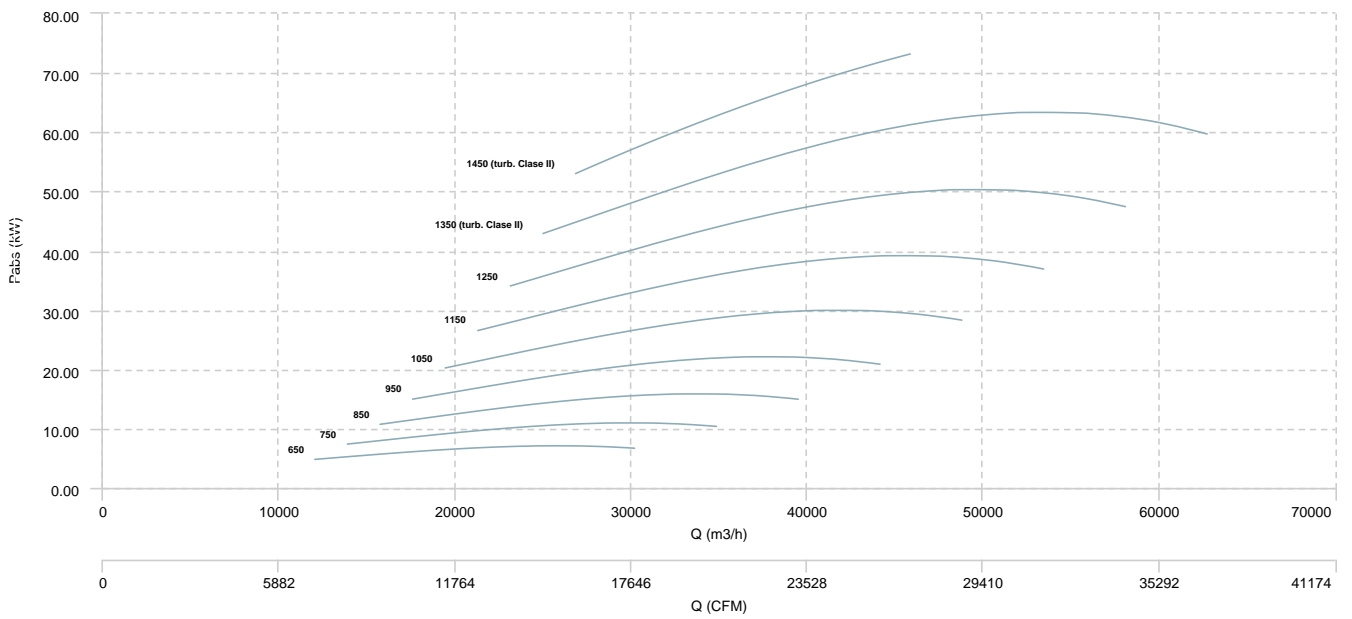

MTRM 1250

AIR FLOW - PRESSURE

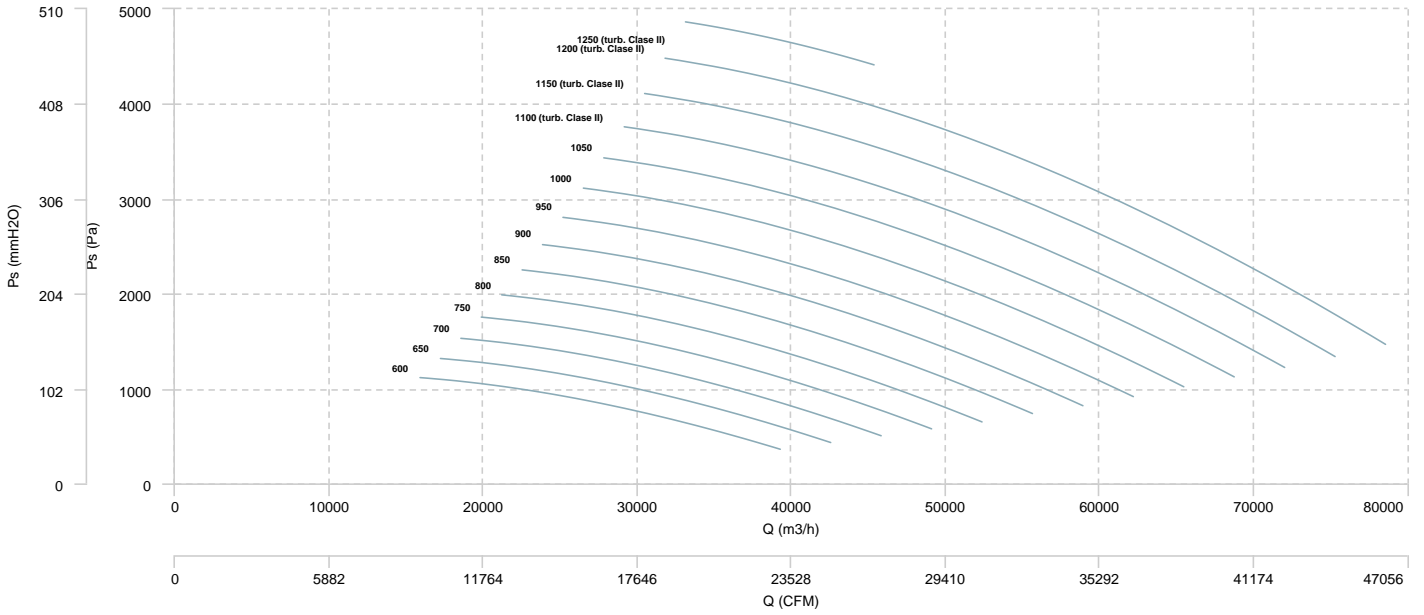

AIR FLOW - MECHANICAL POWER

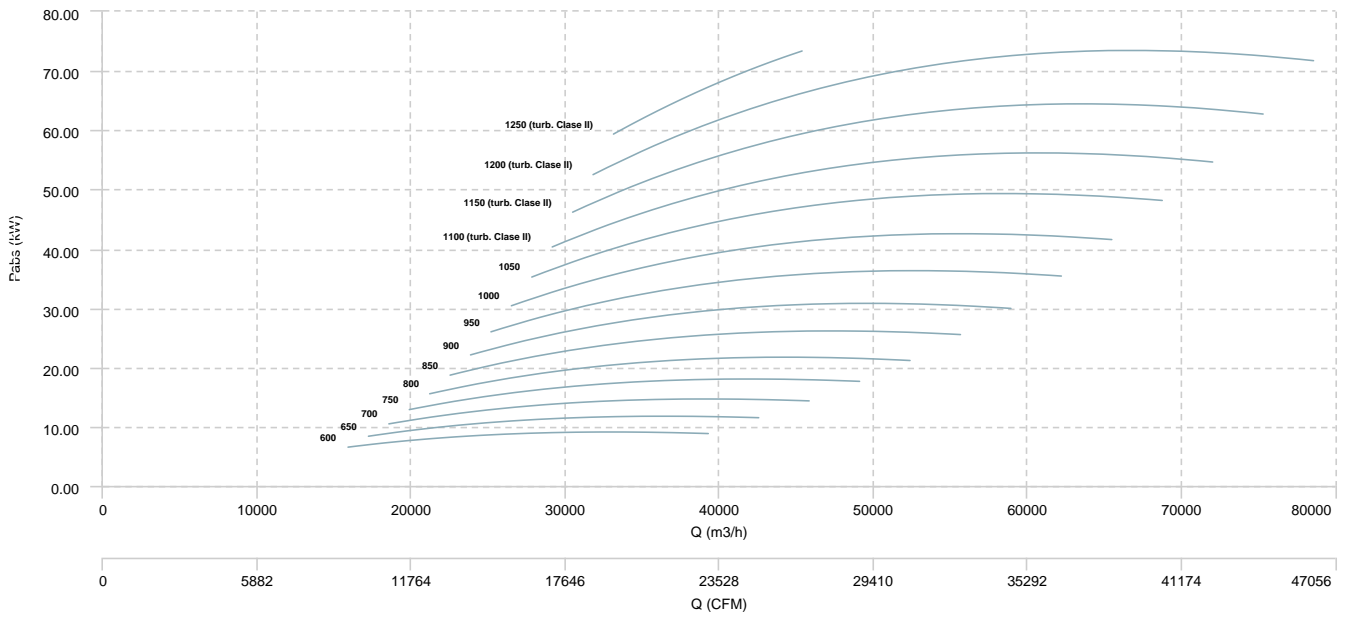

MTRM 1400

AIR FLOW - PRESSURE

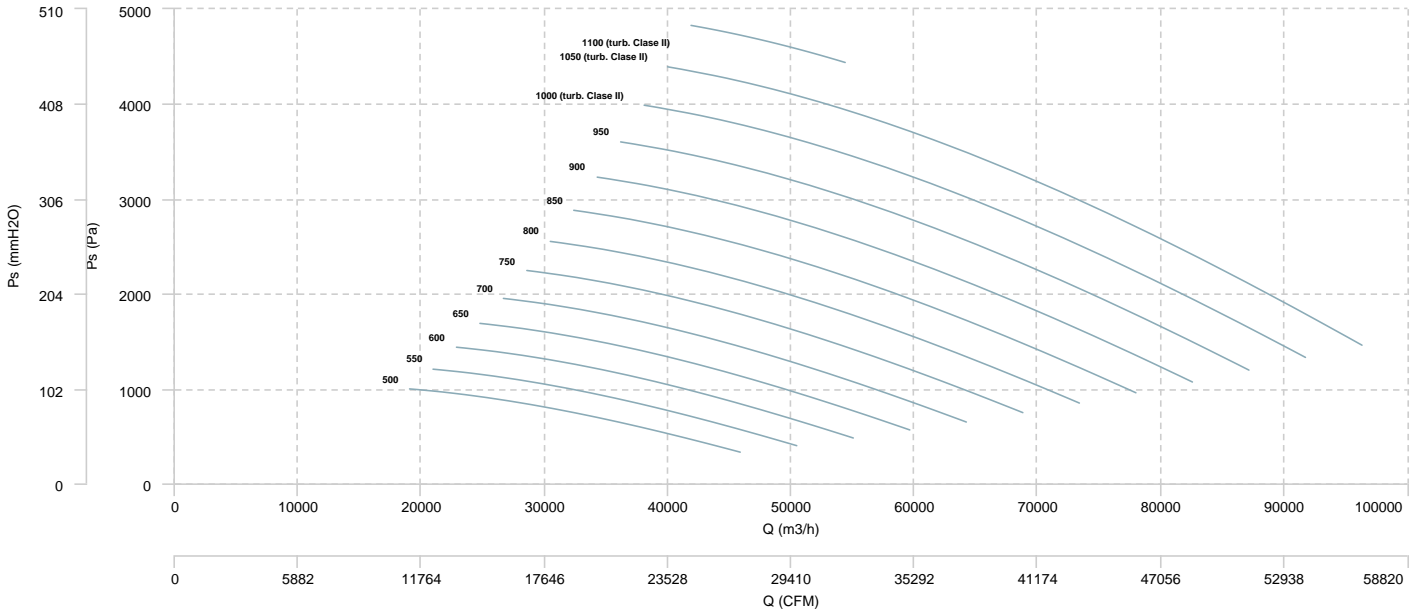

AIR FLOW - MECHANICAL POWER

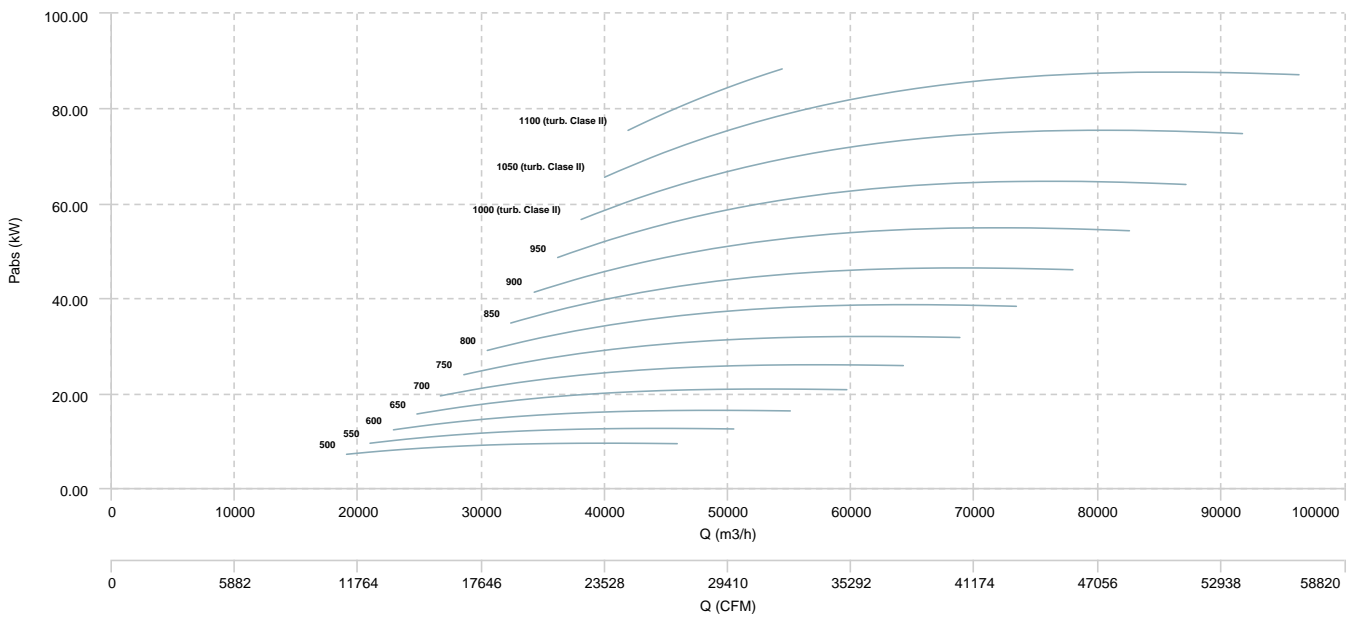

MTRM 1600

AIR FLOW - PRESSURE

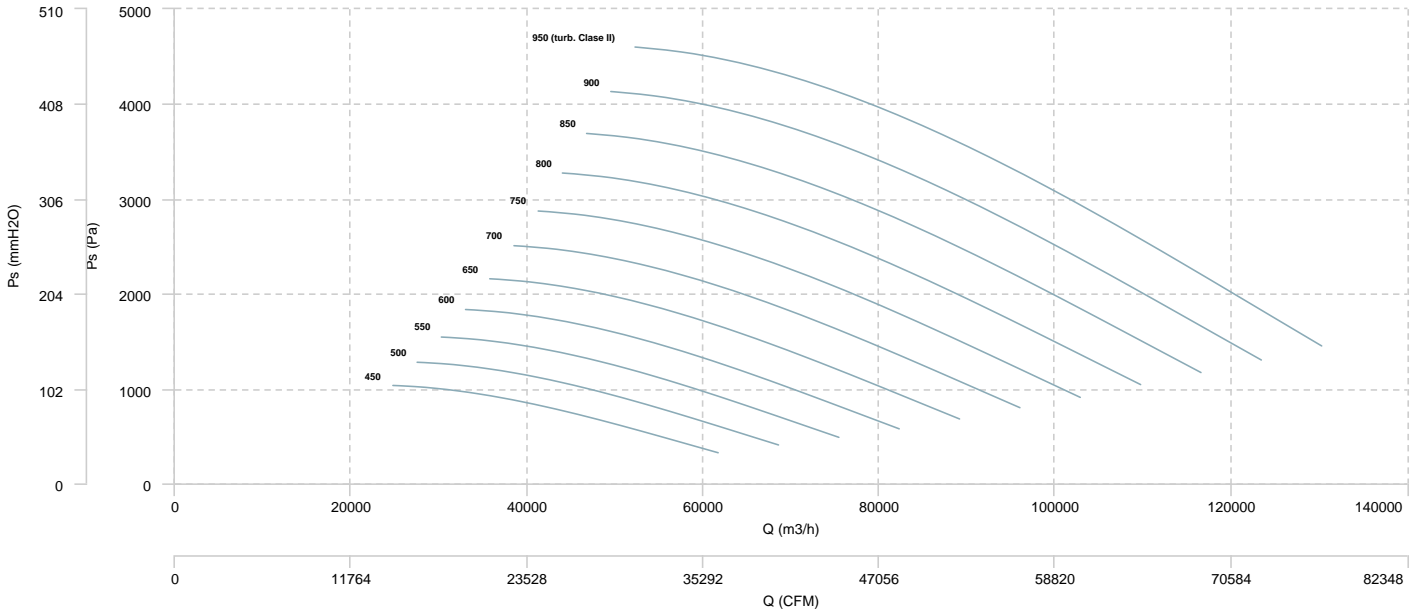

AIR FLOW - MECHANICAL POWER

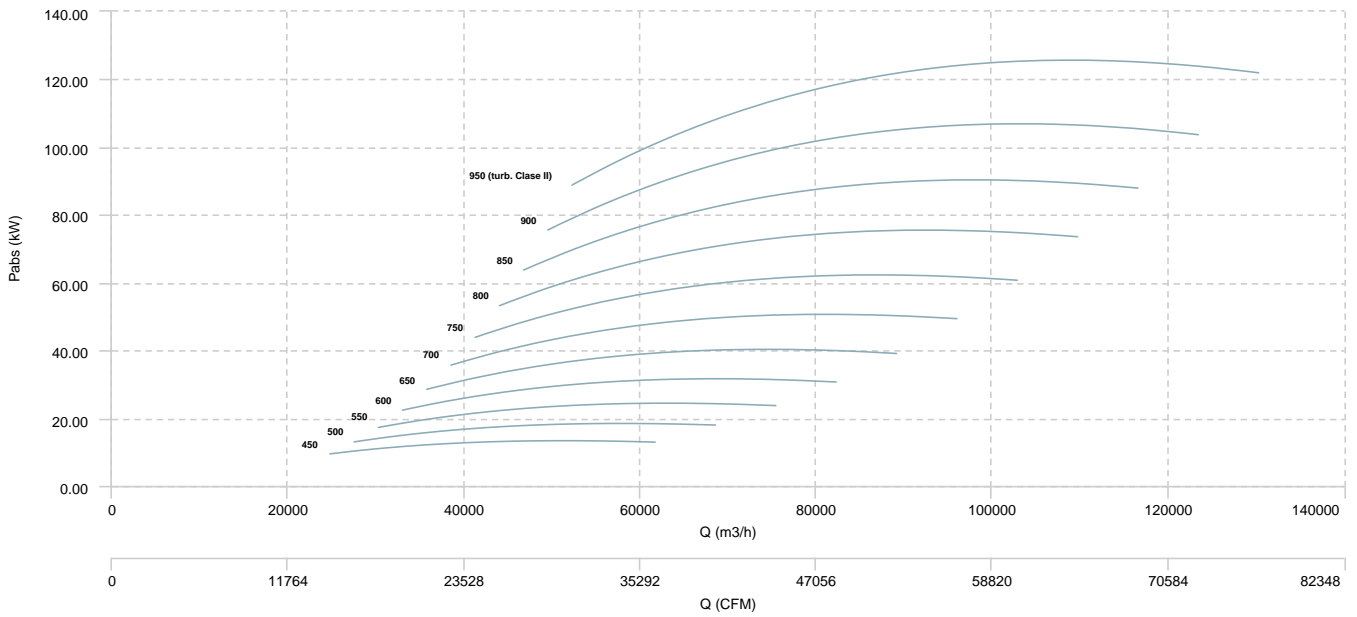

MTRM 1800

AIR FLOW - PRESSURE

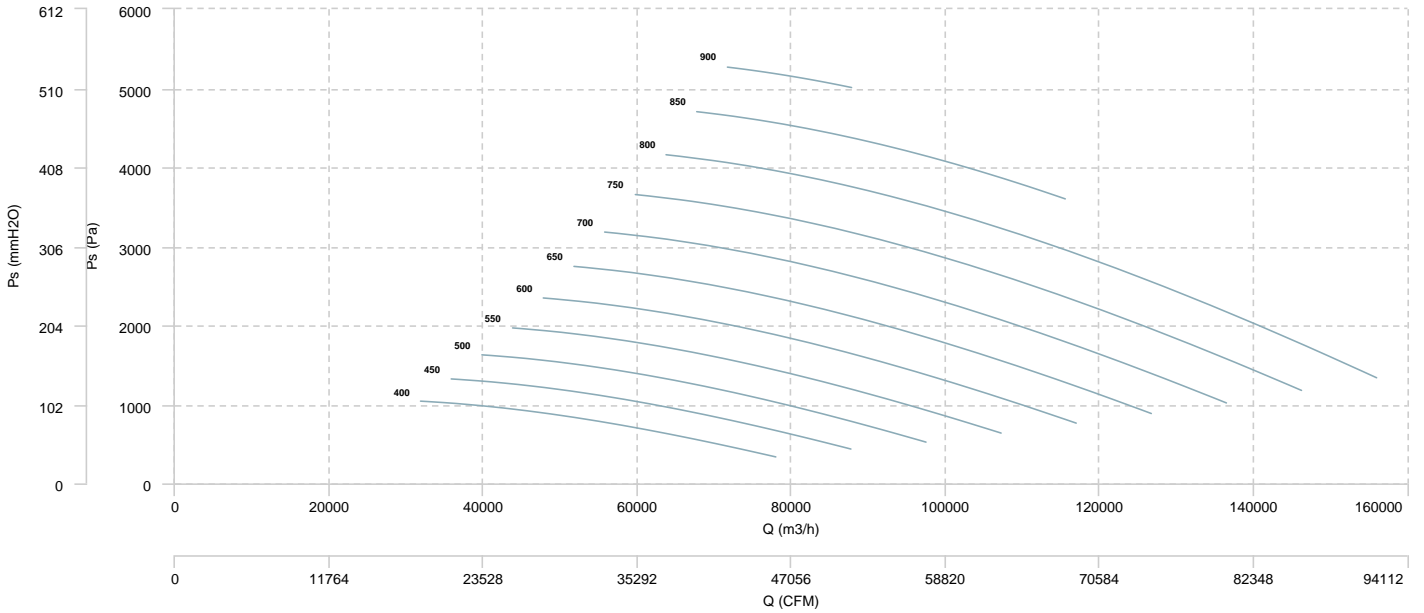

AIR FLOW - MECHANICAL POWER

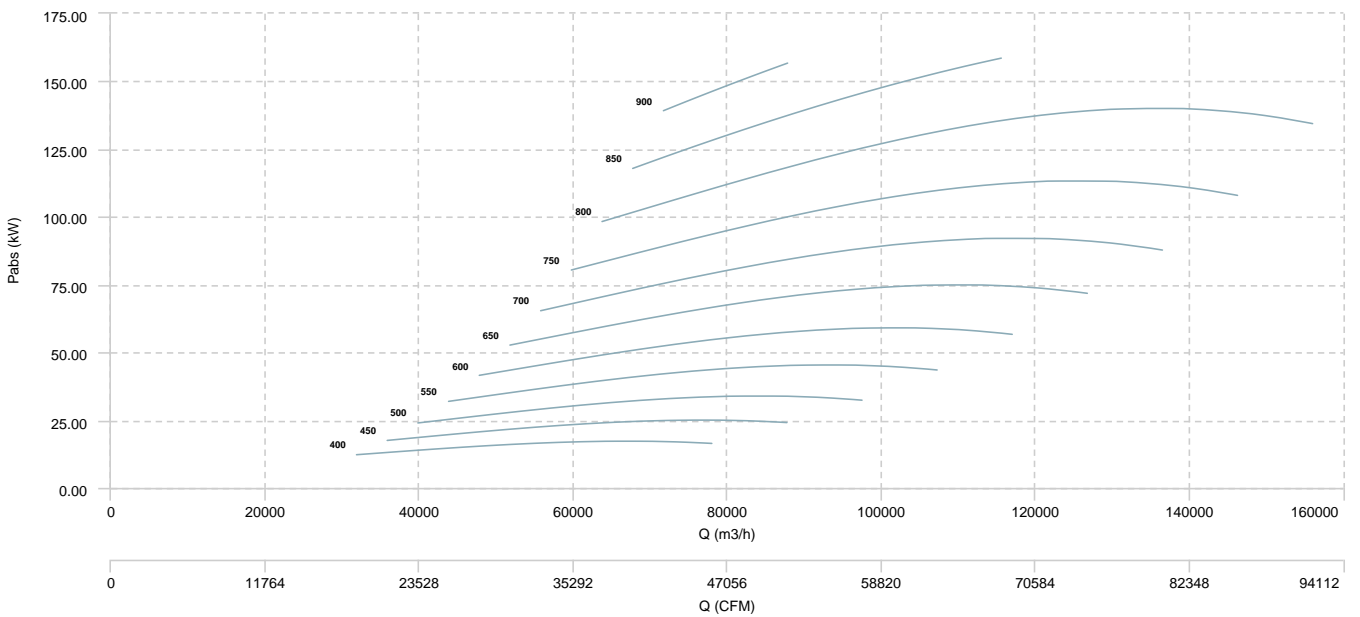

MTRM 2000

AIR FLOW - PRESSURE

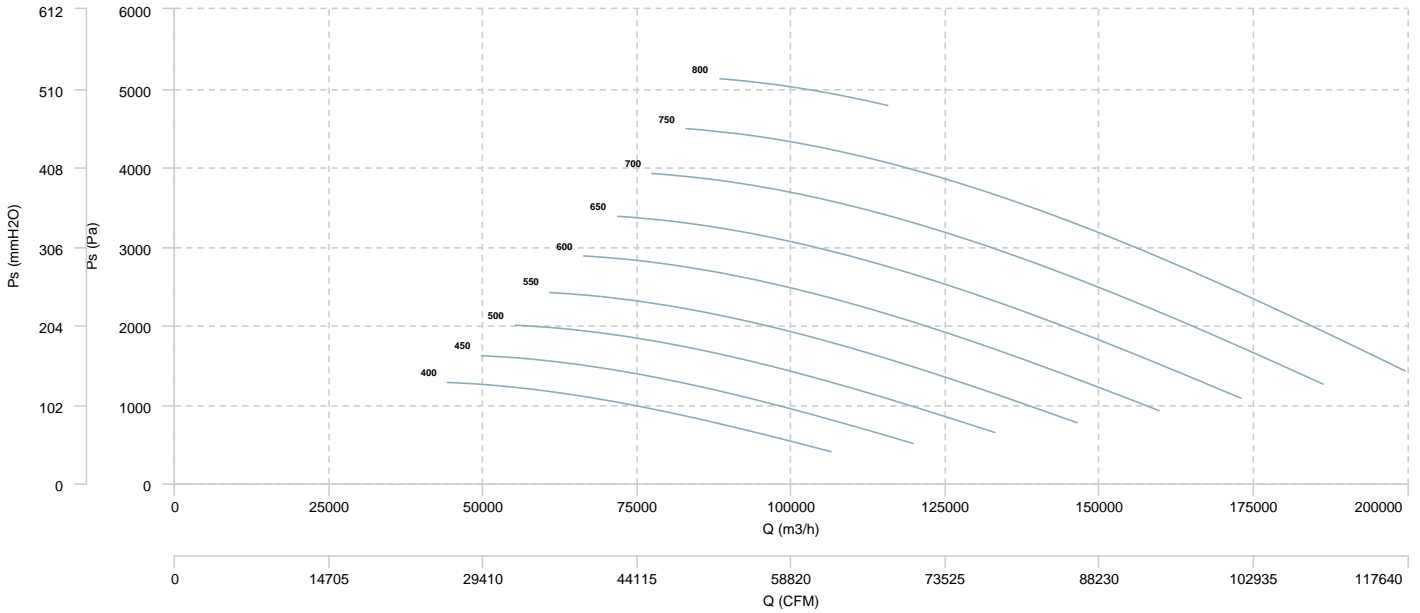

AIR FLOW - MECHANICAL POWER

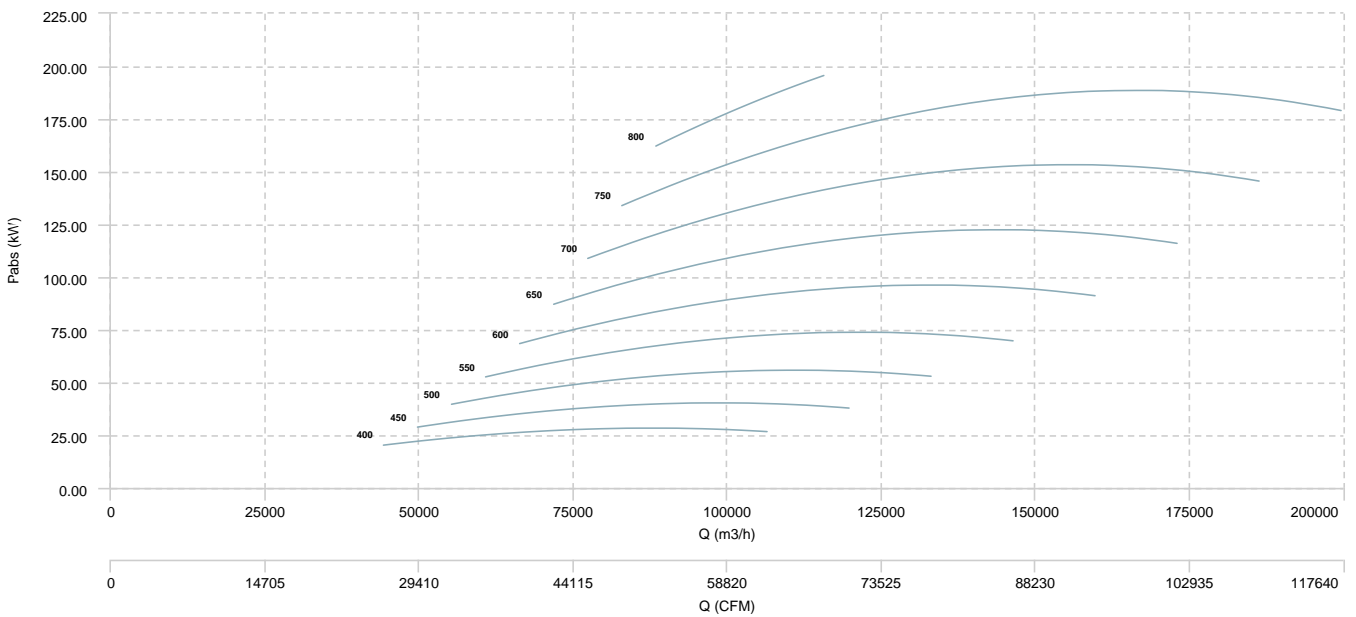

Sound data

Sound power Lw dB (A)										
Model		63 Hz	125 Hz	250 Hz	500 Hz	1000 Hz	2000 Hz	4000 Hz	8000 Hz	Total
MTRM 220 (2850 RPM)	Inlet	46	58	64	68	69	64	58	55	73
MTRM 250 (2250 RPM)	Inlet	44	56	63	67	68	63	56	53	72
MTRM 280 (2250 RPM)	Inlet	47	59	65	69	70	66	59	56	75
MTRM 310 (2250 RPM)	Inlet	50	62	68	72	73	69	62	59	77
MTRM 350 (2000 RPM)	Inlet	51	63	69	73	74	69	63	60	78
MTRM 400 (1800 RPM)	Inlet	51	63	69	73	74	70	63	60	79
MTRM 450 (1600 RPM)	Inlet	52	64	70	74	75	70	64	61	79
MTRM 500 (1450 RPM)	Inlet	53	65	72	76	77	72	65	62	81
MTRM 560 (1250 RPM)	Inlet	53	65	71	75	76	72	65	62	80
MTRM 630 (1150 RPM)	Inlet	55	67	74	78	79	74	68	65	83
MTRM 710 (950 RPM)	Inlet	54	66	73	77	78	73	67	64	82
MTRM 800 (900 RPM)	Inlet	56	68	74	79	79	75	68	65	84
MTRM 900 (800 RPM)	Inlet	57	69	75	79	80	75	69	66	84
MTRM 1000 (750 RPM)	Inlet	58	70	76	80	81	76	70	67	85
MTRM 1120 (650 RPM)	Inlet	58	70	76	80	81	76	70	67	85
MTRM 1250 (600 RPM)	Inlet	59	71	78	82	83	78	72	69	87
MTRM 1400 (500 RPM)	Inlet	58	70	76	81	81	77	70	67	86
MTRM 1600 (450 RPM)	Inlet	60	72	78	82	83	78	72	69	87
MTRM 1800 (400 RPM)	Inlet	60	72	78	82	83	76	72	69	87
MTRM 2000 (400 RPM)	Inlet	64	76	82	86	87	83	76	73	92

Notes:

* To calculate the sound power level at different rpm from those indicated above, use the following formula:

$$Lw \text{ dB(A)}_{rpmA} = Lw \text{ dB(A)}_{rpmB} + 52.5 \cdot \log_{10} \frac{rpmA}{rpmB}$$