

SB-2

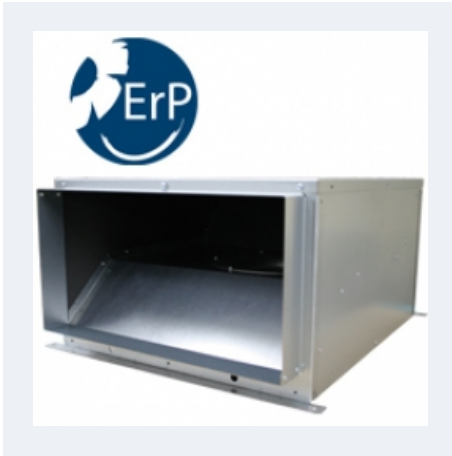

CENTRIFUGAL LOW PROFILE BOX. EXTERNAL ROTOR MOTOR

CONSTRUCTIVE FEATURES:

- Box manufactured in galvanized sheet with thermo-acoustic insulation, Bs1d0 fire class
- Rectangular connection flanges
- Asynchronous external rotor, which includes thermal protector and ball bearings permanently greased. IP-44 protection and insulation class B according to DIN 40.050 h1. Standard voltage 230V 50Hz

APPLICATIONS:

Designed for inline installation, they are suitable for:

- Air renewal in bathrooms and small premises.
- Perfect for installing in false ceilings or open.
- Maximum working temperature: 50°C.

Accessories



INT



REG



REG
VMC



REGD

Technical data

Single-phase motor

Code	Model	R.P.M.	Rated I. (A) 230V	Rated power kW	Max. Airflow m3/h	Sound db (A)**	Weight	Connect. diagram
240160243	SB-2 160	2290	0,27	0,06	410	39	10	1
240200243	SB-2 200	2480	0,42	0,10	770	43	13,50	1
240250243	SB-2 250	2530	0,82	0,19	1.120	48	17,50	1
240280243	SB-2 280	2480	1,05	0,24	1.580	52	23,50	1
240310243	SB-2 315	1400	0,6	0,14	1.550	36	26	1
240350243	SB-2 355	1400	0,75	0,17	2.120	36	35	1
240400243	SB-2 400	1400	1,2	0,26	2.490	39	51	1

Notes:

** Total sound pressure level at the point of maximum flow measured in dB(A) in the suction measured in free field at a distance of 6m from the source

Dimensions

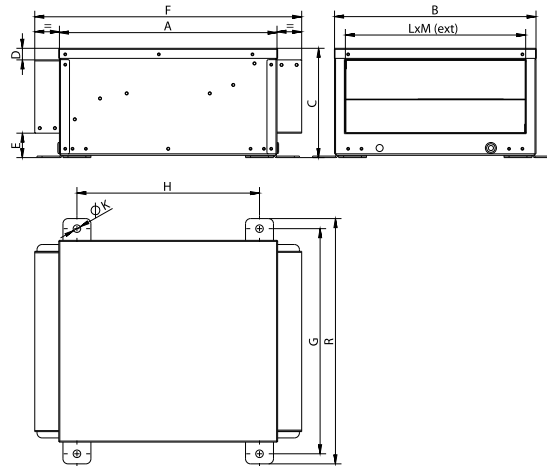

Model	A	B	C	D	E	F(aprox)	G	H	L (ext)
SB-2 160	432	400	217	23	48,5	530	447	362,5	358
SB-2 200	501	453	255,5	23	48,5	609	500	431,5	412
SB-2 250	567	497	305,5	23	48,5	685	554	467,5	456
SB-2 280	637	552	340,5	23	48,5	755	609	437,5	511
SB-2 315	714	618	375,5	23	48,5	837	675	614,5	577
SB-2 355	804	692	445,5	23	48,5	962	749	704,5	651
SB-2 400	908	777	475,5	23	48,5	1066	834	808,5	736

Model	M (ext)	R	ØK
SB-2 160	145,5	487	15
SB-2 200	184	540	15
SB-2 250	234	604	15
SB-2 280	269	659	15
SB-2 315	304	725	15
SB-2 355	374	799	15
SB-2 400	404	884	15

Wiring diagram

DIAGRAM N° 1

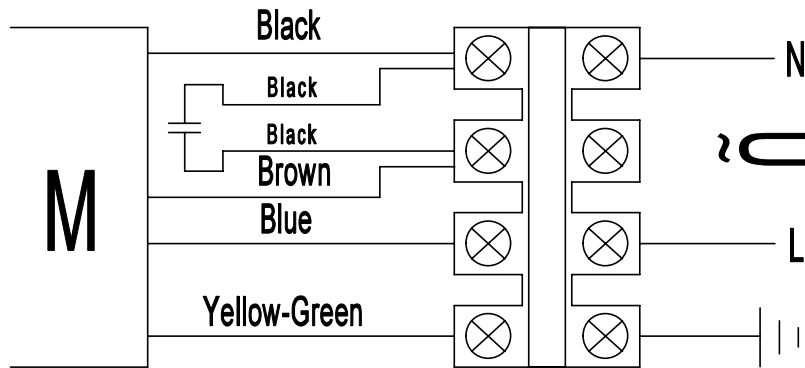

CHARACTERISTIC CURVE

1	SB-2 160	2	SB-2 200	3	SB-2 250	4	SB-2 280
5	SB-2 315	6	SB-2 355	7	SB-2 400		

AIR FLOW - PRESSURE

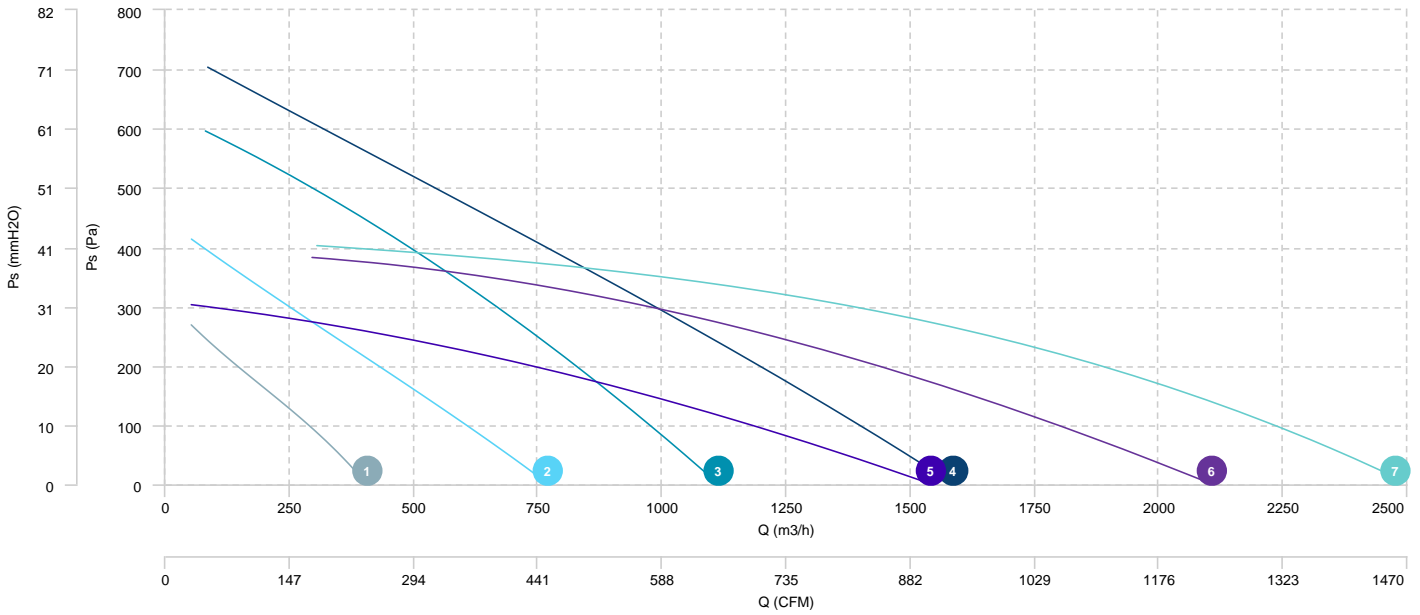

AIR FLOW - ABSORBED POWER

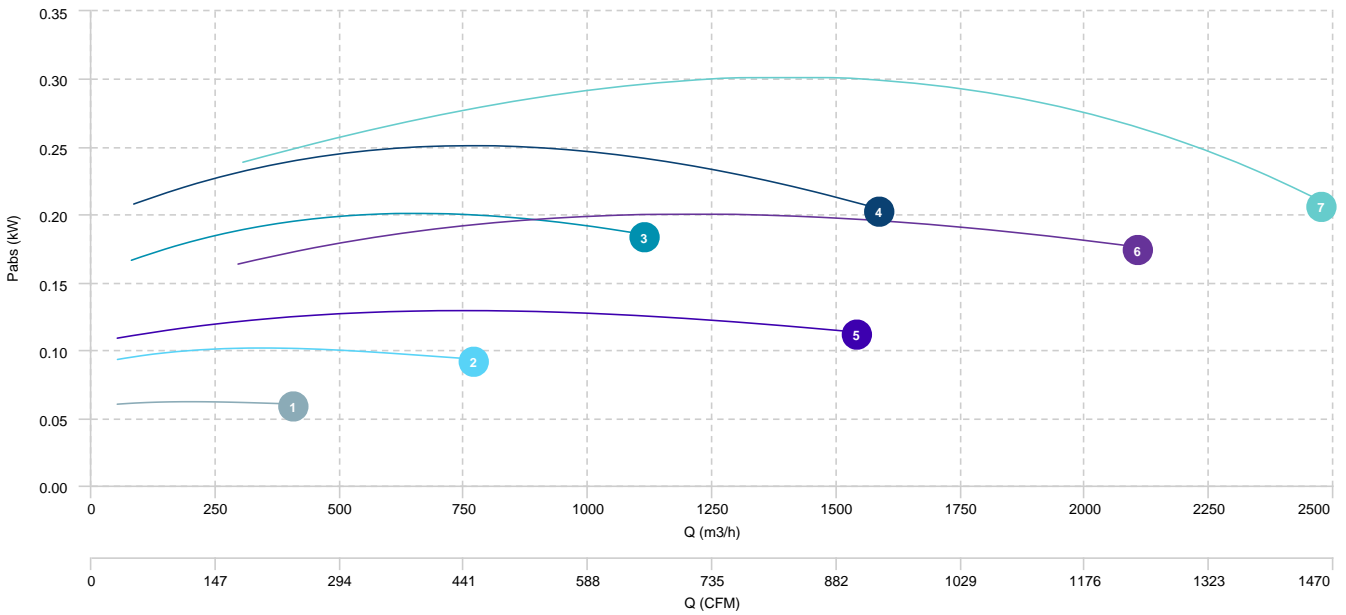

Sound data

Sound power Lw dB (A)										
Model		63 Hz	125 Hz	250 Hz	500 Hz	1000 Hz	2000 Hz	4000 Hz	8000 Hz	Total
SB-2 160	Inlet	62	60	53	48	47	44	41	36	65
SB-2 200	Inlet	66	64	57	52	51	48	45	40	69
SB-2 250	Inlet	71	69	62	57	56	53	50	45	74
SB-2 280	Inlet	75	73	66	61	60	57	54	49	78
SB-2 315	Inlet	59	57	50	45	44	41	38	33	62
SB-2 355	Inlet	59	57	50	45	44	41	38	33	62
SB-2 400	Inlet	62	60	53	48	47	44	41	36	65

erp data

ERP	
Fan type	Unit for non-residential ventilation (LOT 6)
Typology	Unidirectional
Others	None
Type of driver	None

Model	Motor power (kW)	Maximum efficiency point data						
		Eff.Heat recovery (%)	Max. efficiency (%)	Pabs (kW)	Air Flow (m3/h)	Ps (Pa)	Speed (m/s)	SFP (W/m3/s)
SB-2 280	0,24	-	35,04	0,25	847,93	363,17	1.93	1.062,53
SB-2 315	0,14	-	32,73	0,13	841,07	178,71	1.33	551,31
SB-2 355	0,17	-	42,88	0,20	1.181,15	258,87	1.35	610,42
SB-2 400	0,26	-	40,64	0,30	1.556,44	270,42	1.45	693,31