

AXUS

- Vyrábí se ve Velké Británii
- Velikosti od Ø250 mm do Ø1800 mm
- Různé materiálové provedení dílů ventilátorů
- Verze pro vysoké teploty, ATEX a odvod kouře
- Komplexní sortiment příslušenství

Velká řada vysoce výkonných axiálních ventilátorů pro každou aplikaci. AXUS ventilátory mohou být ve více konfiguracích a tím splnit jakékoliv požadavky na větrání. Speciální typy jsou k dispozici pro ATEX provedení, chlazení, potravinářství, zemědělství, apod...

AXUS ventilátory mohou být nabízeny ve „standardním“ formátu střídavě ve speciálních konfiguracích jestliže aplikace vyžaduje tyto požadavky:

Dva rychlostní ventilátory.

Kontra rotující ventilátory pro vysoký tlak.

Možnost provedení s okamžitým nahrazením jednoho ventilátoru druhým. Použití pro nepřetržité provozování a aplikace.

Rozdělené ventilátory s motorem mimo proud vzduchu s nepřetržitým provozem do teploty +80°C. Odpovídají ErP 2015 (kompatibilní).

Rozdělené ventilátory s motorem mimo proud vzduchu až do +230°C pro kontinuální provoz. Z ErP 2015 jsou ventilátory vyřaty, jestliže teplota je obvykle vyšší než +100°C.

ATEX certifikované EXD, EXE, EXN.

Požární provedení do 300°C/2 h, 400°C/2h.

Vzhledem k množství možností, zašlete prosím svůj dotaz s požadovanými technickými parametry. Většina aplikací může být zvolena dle originálního softwaru, více specializované aplikace mohou vyžadovat podrobnější konzultaci.

Dostupné velikosti od Ø250 mm do Ø1800 mm.

Standardní skříň vyrobená z pre-pozinkované oceli. K dispozici také v žárově pozinkované a nerezové oceli.

Barevné provedení k dispozici jako volitelná výbava.

Lopatka ventilátoru materiál: hliník, sklo vyztužený polypropylen, polyamid vyztužený skelným vláknem nebo oceli.

Motory jsou k dispozici pro různá napětí a frekvence.

Vodící lopatky jako volitelná výbava.

Přístupová dvířka jako volitelná výbava.

K dispozici na objednávku s ATEX certifikací až do Eex d IIB T4.

Rozsáhlý sortiment příslušenství je k dispozici pro dokončení instalace. Při instalaci se musí zajistit, aby vibrace se nepřenášely na připojené potrubí.

Upozornění: Podtlakové větrání není vhodné pro prostory s otevřenými spalovacími spotřebiči.

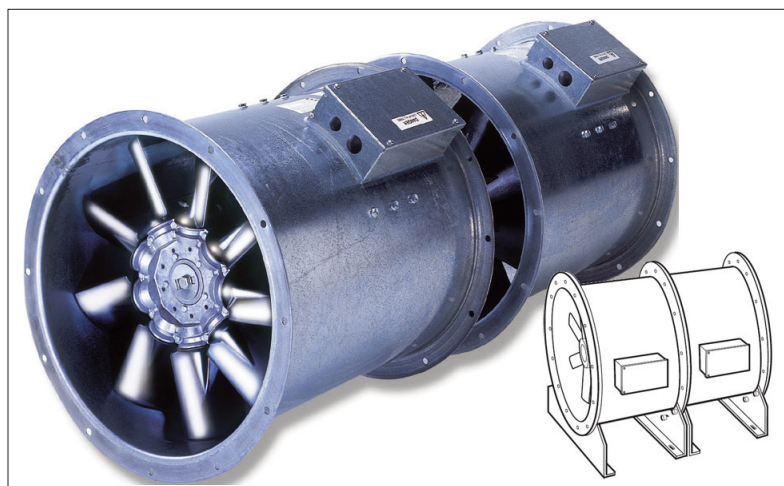

AXUS

Max. množství vzduchu: do 250 000 m³/h i do tlaku 2 500 Pa

Elektrické napětí: 1x230 V nebo 3x 400 V

Výkon motoru(ů): do 55kW , 2, 4, 6 nebo 8 pólový IE2, IE3 nebo speciální typ

Stupně rychlostí: 1 nebo 2

Připojení: Ø250 mm do Ø1800 mm

Další: axiální, potrubní

Příslušenství:-

CMB: Sada montážní konzoly

CMF: Příruba

CFC: Manžeta

NAV: Sada silenbloků

ACJAC: Akustický plášť

CA: Tlumič hluku

CGD: Ochranná mřížka

CIC: Vstupní kužel

CBD: Zpětná klapka

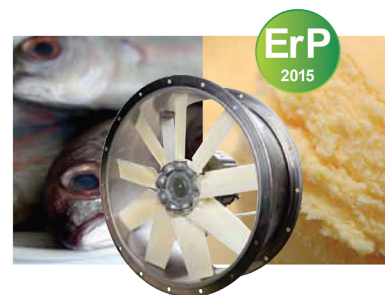
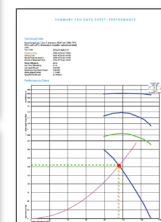
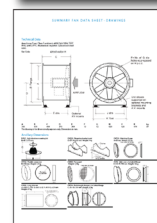
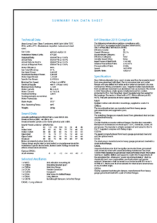
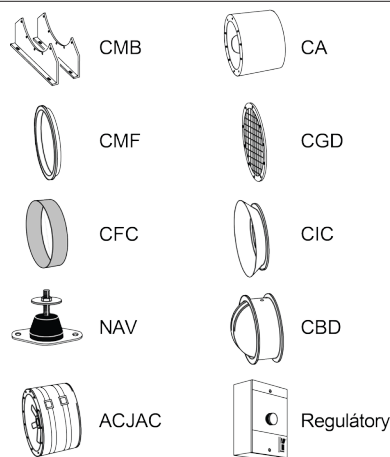



AXIAL RANGE - AMBIENT VENTILATION SOLUTIONS

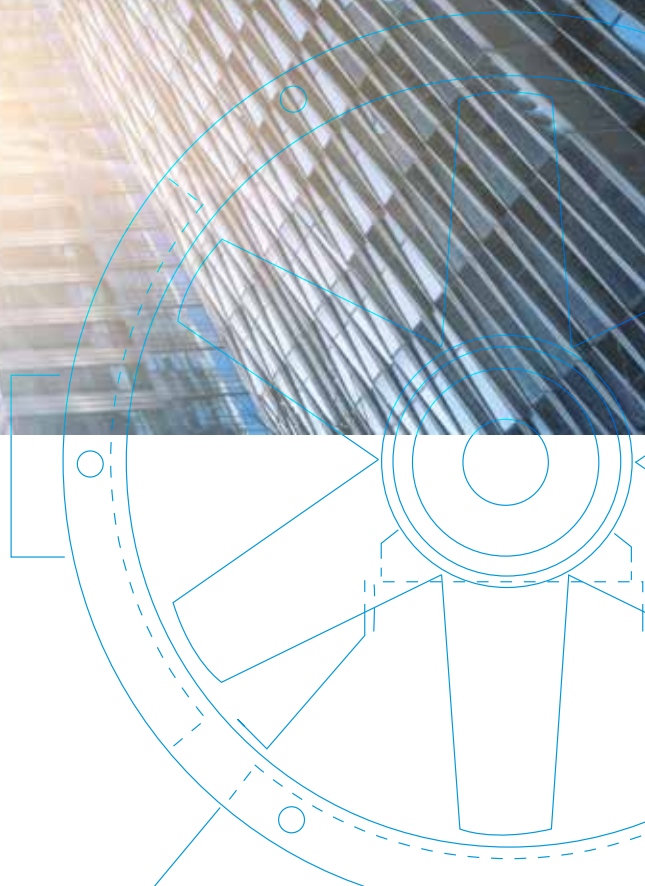

NUAIRE. FOR THE COMPLETE VENTILATION SOLUTION



WITH A RECORD OF QUALITY WHICH IS THE ENVY OF THE INDUSTRY...

...Nuaire is a British company with a long history of innovation in the field of ventilation and air movement solutions, and its products are known across the world for their superb quality and efficiency.

Founded in 1966, Nuaire has a long and much-admired heritage in developing and manufacturing ventilation products. A product range renowned worldwide, coupled with unrivalled customer service which has ensured that Nuaire's products have been distributed globally, including the Middle East, Europe, the USA and Asia.





CONTENTS

The following pages serve to provide a brief overview of the Nuaire Ambient Axial Fan Ranges.

For the best fan solution, selected and tailored to your project and application requirements, please contact Nuaire and/or download the Axial Configurator software, providing access to the expansive range of standard and configurable options available.

	PAGE
AMBIENT AXIAL RANGE	4
250mm Ø	9
315mm Ø	10
350mm Ø	11
400mm Ø	12
450mm Ø	13
500mm Ø	14
560mm Ø	15
630mm Ø	16
710mm Ø	17
800mm Ø	18
900mm Ø	19
1000mm Ø	20
1120mm Ø	21
1250mm Ø	22
1400mm Ø	23
1500mm Ø	23
1600mm Ø	24
MATCHING ANCILLARIES	25
HIGH PRESSURE	26



AMBIENT AXIAL RANGE

AXIAL (AX), CONTRA ROTATING AXIAL (AXC) AND RUN/STANDBY AXIAL (AXT)

Nuaire offer one of the most comprehensive ranges of high performance **circular inline axial flow fans** from 250 to 2000mm diameter to suit every application; with a duty range of up to 120m³/s.



KEY BENEFITS:

- **HIGH PERFORMANCE** - UP TO 120M³/s
- **FLEXIBLE SOLUTION** - SUITABLE FOR INTERNAL & EXTERNAL APPLICATIONS
- **WIDE RANGE** - WITH THE WIDEST RANGE OF AXIAL SOLUTIONS CONFIGURED TO MEET YOUR PROJECT REQUIREMENTS, ENSURING OPTIMUM FAN EFFICIENCIES
- **ENERGY EFFICIENT** - RANGES DEVELOPMENT FOCUSED ON MEETING GLOBAL EFFICIENCY STANDARDS
- **GALVANISED STEEL CONSTRUCTION** - ENSURES STRENGTH, DURABILITY & PROTECTION
- **AMCA APPROVED LABS** - BOTH TYPE 'A' & 'D' LABORATORIES AT NUAIRE ARE ACCREDITED TO THE AMCA 300 STANDARD
- **TESTED TO THE HIGHEST STANDARDS** - AIR PERFORMANCE TO ISO 5801 (PART 1) 2017 WITH ACOUSTIC PERFORMANCE TO AMCA 300 & ISO 13347

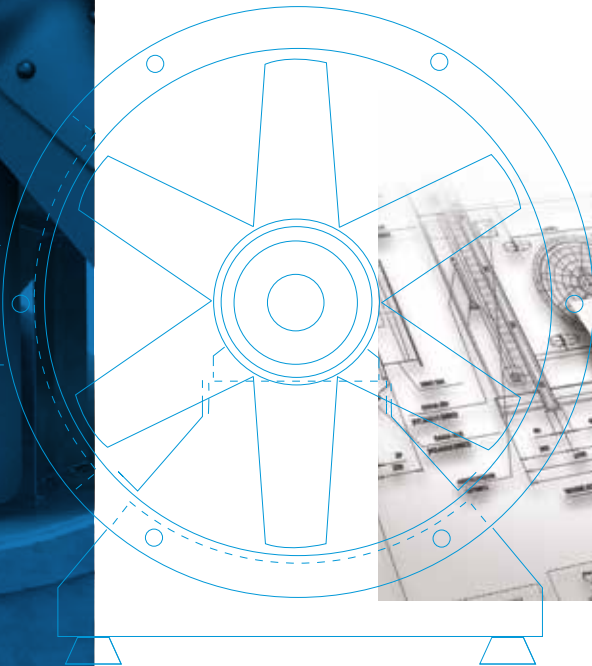



CONSULTANT SPECIFICATION



CASING

Long cased covering both the motor and impeller, manufactured from heavy gauge galvanised steel, corrosion resistant to BS EN10142 1991 with integrally formed inlet and outlet mounting flange, with pre drilled bolt holes.

Cases are available in a standard execution or with integral case mounted guide vanes, unique to Nuairé providing performance enhancing characteristics.

Cases are complete with an externally mounted terminal box which is pre-wired from the motor terminal box, ensuring ease of installation at site.

Case material options available:

- Hot dip galvanized after manufacture
- Painted: Polyester powder or epoxy
- Stainless steel: 304 or 316L



PERFORMANCE

The units are available in a variety of airflows up to a duty of 120m³/s.



CERTIFICATION AND OPERATING TEMPERATURE

All fans are tested for air performance to ISO5801 (Part 1) 2017. Suitable for operation at ambient temperatures of up to 60°C.



NOISE

Tested in accordance to AMCA300 and ISO 12247 for acoustic performance.



MOTOR

Motors incorporated are TEFC (Totally Enclosed Fan Cooled) type of an aluminium or cast iron (dependent on frame size) construction, protected with a paint finish. Protected to IP55 with Class F insulation. Available in both single and three phase supply (50/60Hz).

Motors incorporate integral PTC Thermistors, as standard, ensuring thermal overload protection during the life cycle of the motor.

Motors are suitable for speed control by frequency inverters, subject to fan selection.

There are many other motor options available specific for your project requirements such as:

- IE1, IE2, IE3 and IE4 Efficiency Classes
- 2 speed (Full/Half and Full/Two Thirds)
- 60Hz: Specific to your voltage requirements

Please contact Nuairé or download selection software for the complete range.



ANCILLARIES

- Matching mounting brackets
- Matching flanges
- Flexible connectors
- Anti-vibration mounts
- Acoustic jackets
- Attenuators
- Guards
- Inlet cones
- Backdraught dampers
- Controls



IMPELLER

Impellers are either aerofoil or sickle in section and variable pitch with an extensive range of blade profile combinations ensuring optimum performance, efficiency and sound characteristics.

Impeller hubs are manufactured from fully die cast aluminium alloy as standard.

Blade materials are available in:

- Aluminium: Fully cast
- PPG: Glass Reinforced Polypropylene
- PAG: Glass Reinforced Polyamide



INSTALLATION

The units are suitable for installation both internally and externally and installed at any angle.



APPLICATIONS

TYPICAL APPLICATIONS

- Boiler rooms
- Lift motor rooms
- Sports halls
- Factories & warehouses
- Car parks & smoke
- Industrial
- Hospitals, surgeries & medical centres
- Offices & commercial
- Supermarkets
- Retail, leisure & sports facilities
- Public buildings

For fan solutions specific to your project applications, please contact Nuairé for further details.



AXIAL - SINGLE STAGE (AX)

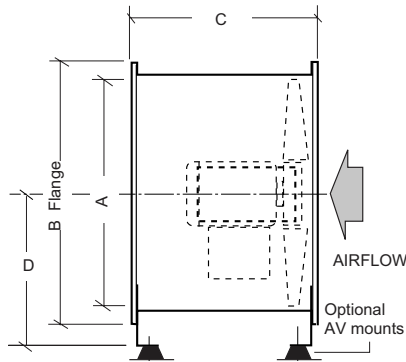

CODING AX100X-X

AX 100 X - X
 | | | |
 1 2 3 4

SAMPLE CODING

1. Axial fan
2. Size of casing in cm
3. Impeller specification reference
4. Motor speed in poles

DIMENSIONS (mm)

MODEL	A	B	C	D
AX31	315	400	365	210
AX35	350	430	380	240
AX40	400	490	440	270
AX45	450	540	450	300
AX45	450	540	600	300
AX50	500	608	465	340
AX50	500	608	615	340
AX56	560	670	440	370
AX56	560	670	615	370
AX63	630	740	480	430
AX63	630	740	600	430
AX63	630	740	800	430
AX71	710	814	455	470
AX71	710	814	700	470
AX80	800	910	440	540
AX80	800	910	840	540
AX90	900	1016	740	600
AX100	1000	1128	740	670
AX100	1000	1128	850	670
AX112	1120	1240	730	750
AX112	1120	1240	865	750
AX112	1120	1240	1010	750
AX125	1250	1365	1010	830
AX125	1250	1365	1010	830

RANGE PERFORMANCE ENVELOPE

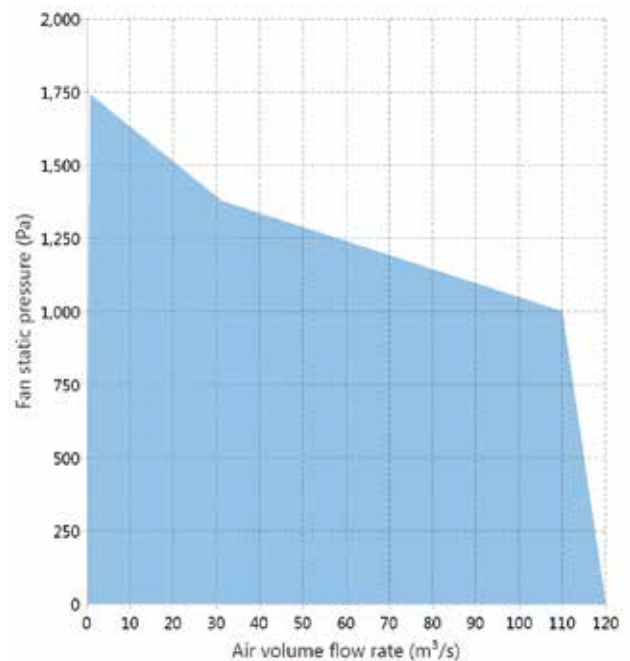

Unit sizes 1400mm and above contact Nuair for details.

For High Pressure range refer to pages 26-31.

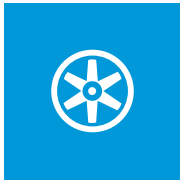

CONTRA ROTATING AXIAL - 2 STAGE (AXC)

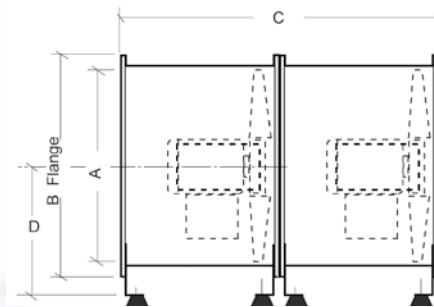

CODING AXC100X-X

AXC 100 X - X
 | | | |
 1 2 3 4

SAMPLE CODING

1. Contra rotating axial fan set
2. Size of casing in cm
3. Impeller specification reference
4. Motor speed in poles

DIMENSIONS (mm)

MODEL	A	B	C	D
AXC31	315	400	730	210
AXC35	350	430	760	240
AXC40	400	490	880	270
AXC45	450	540	900	300
AXC50	500	608	930	340
AXC50	500	608	1230	340
AXC56	560	670	880	370
AXC56	560	670	1230	370
AXC63	630	740	960	430
AXC63	630	740	1200	430
AXC71	710	814	910	470
AXC71	710	814	1400	470
AXC80	800	910	880	540
AXC80	800	910	1680	540
AXC90	900	1016	1480	600
AXC100	1000	1128	1480	670
AXC100	1000	1128	1700	670
AXC112	1120	1240	1460	750
AXC112	1120	1240	1730	750
AXC112	1120	1240	2020	750
AXC125	1250	1365	1730	830
AXC125	1250	1365	2020	830

RANGE PERFORMANCE ENVELOPE

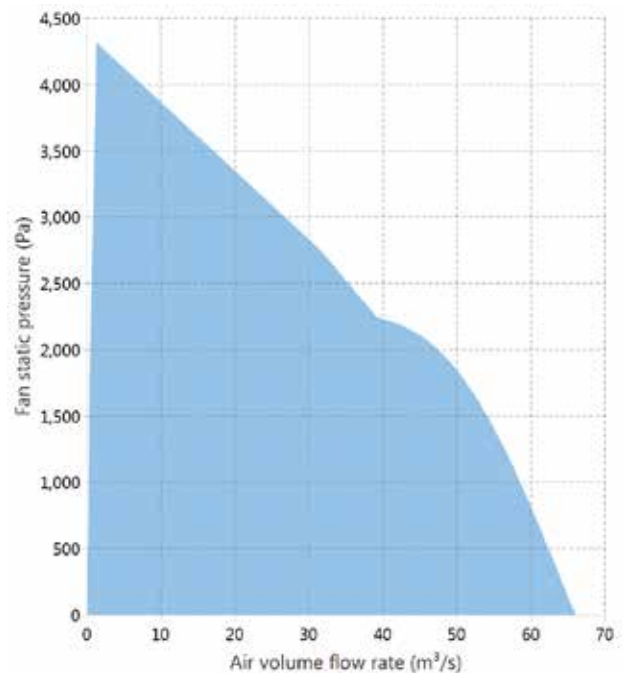

For unit sizes 1400mm and above contact Nuair for details.



AXIAL RUN & STANDBY IN SERIES - 2 STAGE (AXT)

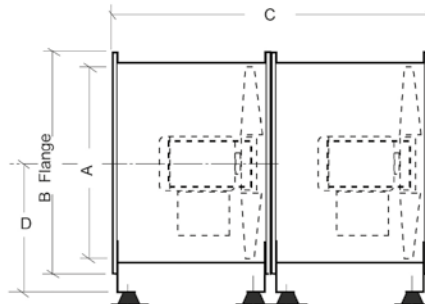

CODING AXT100X-X

AXT 100 X - X
 | | | |
 1 2 3 4

SAMPLE CODING

1. Axial fan set (Run & Standby) in Series
2. Size of casing in cm
3. Impeller specification reference
4. Motor speed in poles

DIMENSIONS (mm)

MODEL	A	B	C	D
AXT31	315	400	730	210
AXT35	350	430	760	240
AXT40	400	490	880	270
AXT45	450	540	900	300
AXT50	500	608	930	340
AXT50	500	608	1230	340
AXT56	560	670	880	370
AXT56	560	670	1230	370
AXT63	630	740	960	430
AXT63	630	740	1200	430
AXT71	710	814	910	470
AXT71	710	814	1400	470
AXT80	800	910	880	540
AXT80	800	910	1680	540
AXT90	900	1016	1480	600
AXT100	1000	1128	1480	670
AXT100	1000	1128	1700	670
AXT112	1120	1240	1460	750
AXT112	1120	1240	1730	750
AXT112	1120	1240	2020	750
AXT125	1250	1365	1730	830
AXT125	1250	1365	2020	830

RANGE PERFORMANCE ENVELOPE

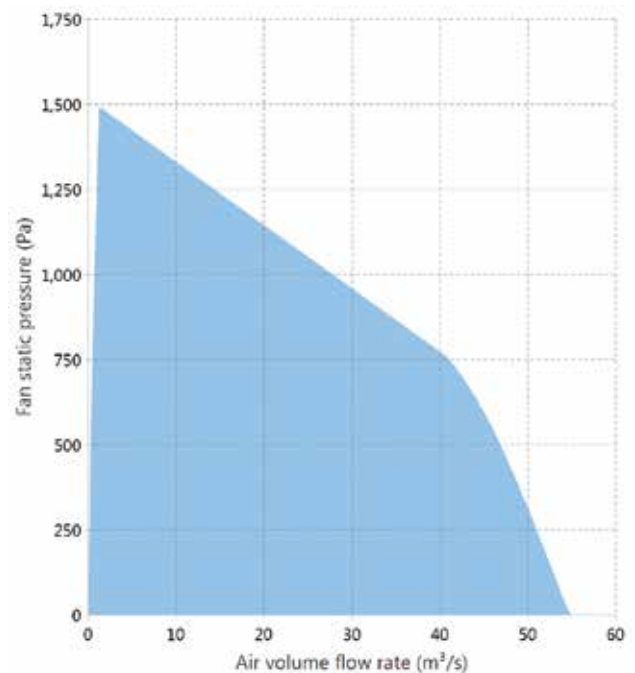

For unit sizes 1400mm and above contact Nuair for details.

250mm Ø

2 POLE

4 POLE



Details illustrated are a small representation of the complete range. Please contact Nuairé for selections specific to your project applications and/or request software download.

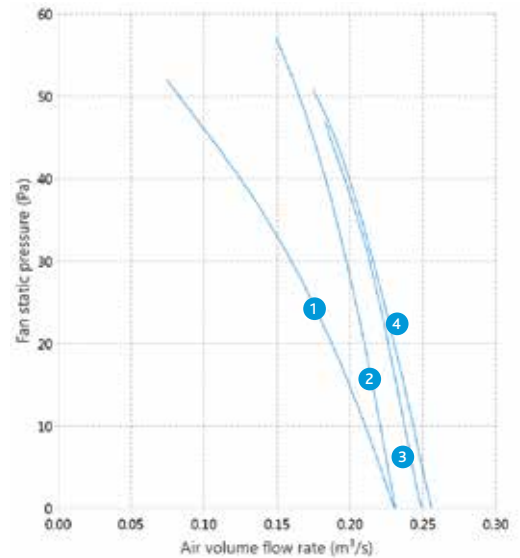
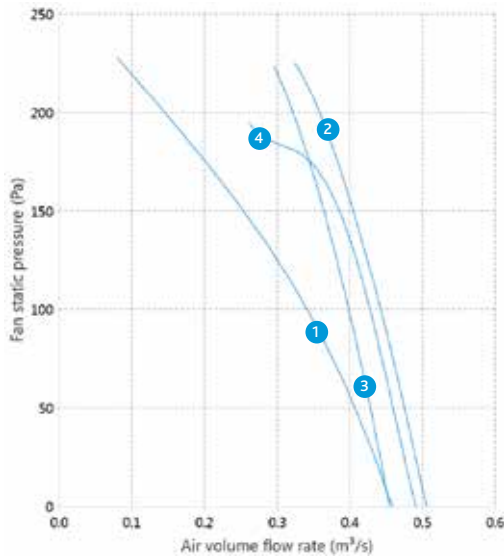

250mm Ø 2 POLE

CURVE	FAN CODE	BLADE ANGLE °	MOTOR RATING (kW)	RPM SPEED	MOTOR CURRENTS		SOUND POWER LEVELS RE 1 PWATT (Hz) INDUCT INLET								
					FLC	SC (DOL)	63	125	250	500	1K	2K	4K	8K	dB(A) @3M
1	AX25F-2	35	0.22	2710	0.66	3.3	95	85	82	77	72	69	64	57	43
2	AX25D-2	30	0.22	2710	0.66	3.3	72	79	72	73	69	65	61	53	39
3	AX25F-2	40	0.30	2710	0.85	4.26	93	90	81	78	74	70	63	57	44
4	AX25A-2	25	0.22	2710	0.66	3.3	69	101	76	79	66	60	53	46	44

250mm Ø 4 POLE

CURVE	FAN CODE	BLADE ANGLE °	MOTOR RATING (kW)	RPM SPEED	MOTOR CURRENTS		SOUND POWER LEVELS RE 1 PWATT (Hz) INDUCT INLET								
					FLC	SC (DOL)	63	125	250	500	1K	2K	4K	8K	dB(A) @3M
1	AX25A-4	25	0.14	1360	0.66	2.2	82	74	65	56	51	47	39	29	26
2	AX25F-4	35	0.14	1360	0.66	2.2	76	73	70	62	59	52	45	38	28
3	AX25D-4	30	0.14	1360	0.66	2.2	72	76	68	60	55	52	45	36	28
4	AX25F-4	40	0.14	1360	0.66	2.2	77	79	72	63	60	53	45	39	30

315mm Ø

2 POLE

4 POLE



Details illustrated are a small representation of the complete range. Please contact Nuair for selections specific to your project applications and/or request software download.

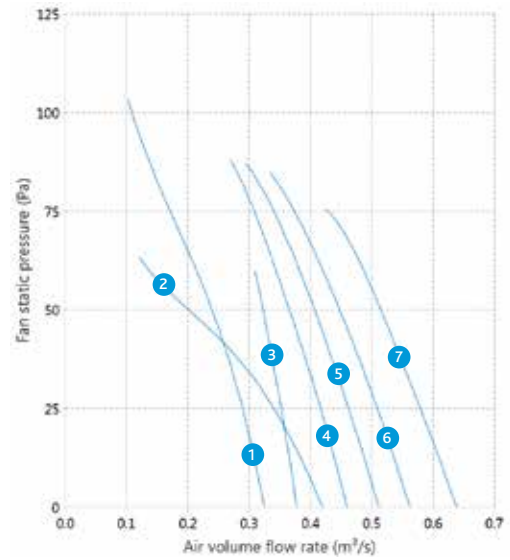
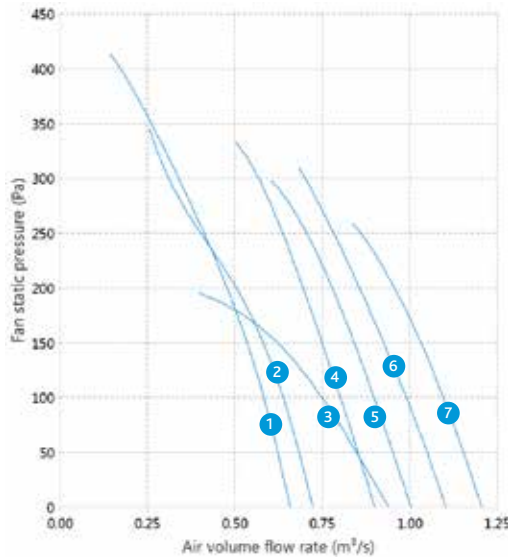

315mm Ø 2 POLE

CURVE	FAN CODE	BLADE ANGLE °	MOTOR RATING (KW)	RPM SPEED	FLC	SC (DOL)	MOTOR CURRENTS		SOUND POWER LEVELS RE 1 PWATT (Hz) INDUCT INLET							
							63	125	250	500	1K	2K	4K	8K	dB(A) @3M	
1	AX31M-2	20	0.30	2710	0.85	4.26	86	81	97	80	78	74	70	63	53	
2	AX31X-2	25	0.44	2730	1.16	5.82	98	98	85	78	77	75	71	68	48	
3	AX31A-2	30	0.22	2710	0.66	3.3	84	96	84	79	76	72	66	61	46	
4	AX31X-2	60	0.44	2730	1.16	5.82	88	85	83	79	77	73	69	64	47	
5	AX31X-2	35	0.66	2760	1.70	8.52	87	84	91	81	79	75	71	64	49	
6	AX31X-2	40	0.66	2760	1.70	8.52	85	84	87	79	79	76	70	65	48	
7	AX31F-2	45	0.90	2848	2.15	10.74	87	85	84	82	81	77	72	67	49	

315mm Ø 4 POLE

CURVE	FAN CODE	BLADE ANGLE °	MOTOR RATING (KW)	RPM SPEED	FLC	SC (DOL)	MOTOR CURRENTS		SOUND POWER LEVELS RE 1 PWATT (Hz) INDUCT INLET							
							63	125	250	500	1K	2K	4K	8K	dB(A) @3M	
1	AX31M-4	20	0.14	1360	0.66	2.2	76	85	72	65	61	58	50	42	33	
2	AX31A-4	25	0.14	1360	0.66	2.2	86	73	62	58	58	57	51	42	27	
3	AX31F-4	25	0.14	1360	0.66	2.2	77	71	71	66	63	60	54	44	33	
4	AX31X-4	30	0.14	1360	0.66	2.2	78	79	72	64	61	57	49	43	32	
5	AX31X-4	35	0.14	1360	0.66	2.2	72	78	70	63	61	57	48	41	31	
6	AX31X-4	40	0.14	1360	0.66	2.2	71	82	71	64	62	58	51	45	32	
7	AX31F-4	45	0.14	1360	0.66	2.2	68	73	74	63	63	59	54	48	34	

350mm Ø

2 POLE

4 POLE



Details illustrated are a small representation of the complete range. Please contact Nuair for selections specific to your project applications and/or request software download.

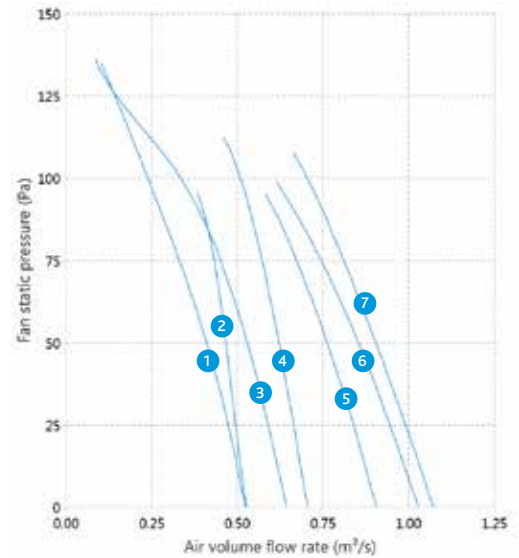
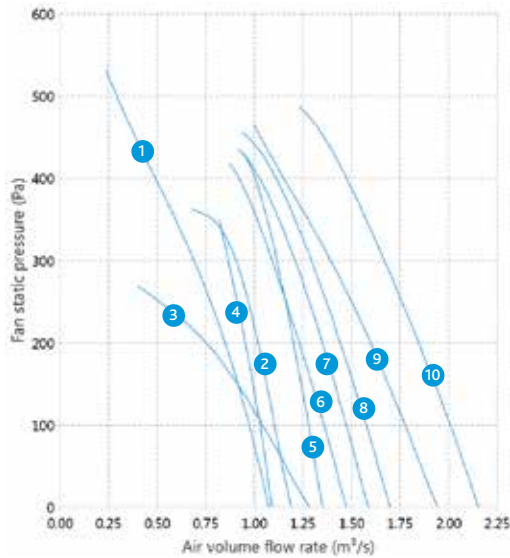

350mm Ø 2 POLE

CURVE	FAN CODE	BLADE ANGLE °	MOTOR RATING (KW)	RPM SPEED	MOTOR CURRENTS		SOUND POWER LEVELS RE 1 PWATT (Hz) INDUCT INLET								
					FLC	SC (DOL)	63	125	250	500	1K	2K	4K	8K	dB(A) @3M
1	AX35M-2	20	0.44	2730	1.16	5.82	88	81	88	79	81	76	72	67	50
2	AX35A-2	25	0.30	2710	0.85	4.26	86	81	79	77	76	71	67	62	44
3	AX35I-2	45	0.66	2760	1.70	8.52	84	78	76	83	81	77	76	69	49
4	AX35F-2	25	0.90	2848	2.15	10.74	86	79	78	82	80	77	75	68	48
5	AX35I-2	30	1.32	2850	2.90	16.46	90	81	78	82	81	78	75	70	49
6	AX35I-2	30	0.90	2840	2.10	10.15	85	85	96	81	80	76	73	65	54
7	AX35X-2	32.5	0.90	2840	2.10	10.15	87	87	89	83	84	78	74	67	51
8	AX35X-2	35	1.32	2850	2.90	16.46	87	87	88	82	83	79	74	68	51
9	AX35M-2	40	1.32	2846	2.92	14.58	87	86	102	82	82	79	74	69	60
10	AX35F-2	45	1.80	2850	3.84	22.08	89	88	85	86	85	81	76	71	53

350mm Ø 4 POLE

CURVE	FAN CODE	BLADE ANGLE °	MOTOR RATING (KW)	RPM SPEED	MOTOR CURRENTS		SOUND POWER LEVELS RE 1 PWATT (Hz) INDUCT INLET								
					FLC	SC (DOL)	63	125	250	500	1K	2K	4K	8K	dB(A) @3M
1	AX35M-4	20	0.14	1360	0.66	2.2	74	81	69	66	64	61	56	50	33
2	AX31I-4	25	0.14	1360	0.66	2.2	70	70	73	71	67	63	58	49	36
3	AX35M-4	25	0.14	1360	0.66	2.2	76	81	69	64	63	60	55	47	33
4	AX35D-4	30	0.14	1360	0.66	2.2	74	70	79	63	63	62	56	49	38
5	AX35D-4	35	0.14	1360	0.66	2.2	72	70	72	64	62	61	55	48	41
6	AX35D-4	40	0.14	1360	0.66	2.2	72	70	72	64	61	58	52	47	38
7	AX35D-4	45	0.22	1310	0.84	2.8	76	73	78	65	65	61	57	53	39

400mm Ø

2 POLE

4 POLE



Details illustrated are a small representation of the complete range. Please contact Nuair for selections specific to your project applications and/or request software download.

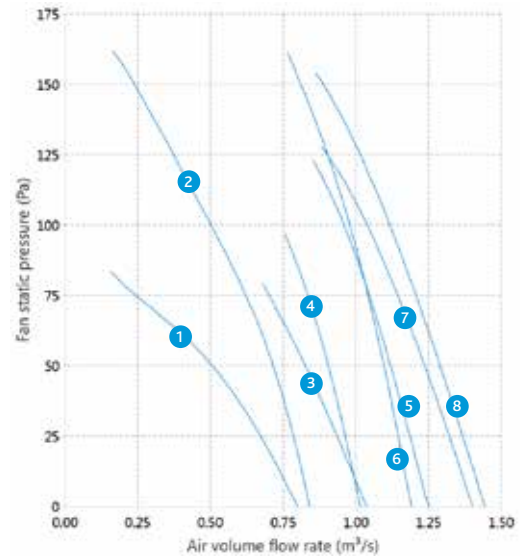
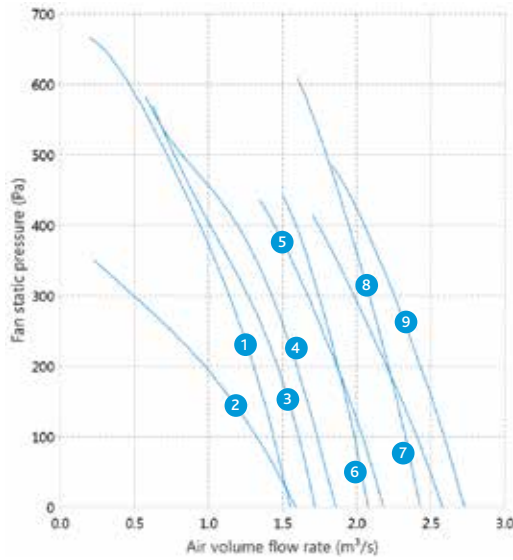

400mm Ø 2 POLE

CURVE	FAN CODE	BLADE ANGLE °	MOTOR RATING (KW)	RPM SPEED	FLC	SC (DOL)	MOTOR CURRENTS								SOUND POWER LEVELS RE 1 PWATT (Hz) INDUCT INLET				dB(A) @3M
							63	125	250	500	1K	2K	4K	8K					
1	AX40M-2	20	0.90	2848	2.15	10.74	90	81	89	83	84	79	74	71	51				
2	AX40A-2	25	0.44	2730	1.16	5.82	80	84	87	81	79	74	69	67	47				
3	AX40D-2	25	0.90	2848	2.15	10.74	91	79	82	86	84	80	76	82	52				
4	AX40M-2	25	1.32	2846	2.92	14.58	98	81	92	83	84	80	76	72	53				
5	AX40M-2	30	1.32	2850	2.90	16.46	92	83	94	83	83	78	73	68	53				
6	AX40F-2	30	1.80	2850	3.84	22.08	91	82	83	90	85	81	76	70	51				
7	AX40I-2	35	2.64	2860	5.45	35.87	95	84	82	90	84	80	75	71	52				
8	AX40M-2	37.5	2.64	2860	5.45	35.87	90	85	98	86	86	83	78	74	57				
9	AX40F-2	40	3.60	2880	7.32	36.6	99	89	82	88	86	81	76	72	52				

400mm Ø 4 POLE

CURVE	FAN CODE	BLADE ANGLE °	MOTOR RATING (KW)	RPM SPEED	FLC	SC (DOL)	MOTOR CURRENTS								SOUND POWER LEVELS RE 1 PWATT (Hz) INDUCT INLET				dB(A) @3M
							63	125	250	500	1K	2K	4K	8K					
1	AX40A-4	25	0.14	1360	0.66	2.2	75	75	69	66	63	61	55	46	34				
2	AX40D-4	25	0.14	1360	0.66	2.2	75	71	81	69	66	64	58	51	42				
3	AX40E-4	30	0.14	1360	0.66	2.2	78	75	72	68	65	63	59	52	34				
4	AX40D-4	30	0.22	1310	0.84	2.8	75	68	75	68	66	64	59	52	37				
5	AX40F-4	35	0.30	1350	1.01	5.04	78	69	80	67	66	63	58	52	38				
6	AX40I-4	35	0.44	1370	1.33	6.66	76	71	78	70	68	65	60	54	38				
7	AX40F-4	40	0.44	1370	1.33	6.66	79	72	83	69	66	63	58	54	40				
8	AX40I-4	45	0.44	1370	1.33	6.66	82	76	77	71	69	64	60	55	39				

450mm Ø

2 POLE

4 POLE



Details illustrated are a small representation of the complete range. Please contact Nuairé for selections specific to your project applications and/or request software download.

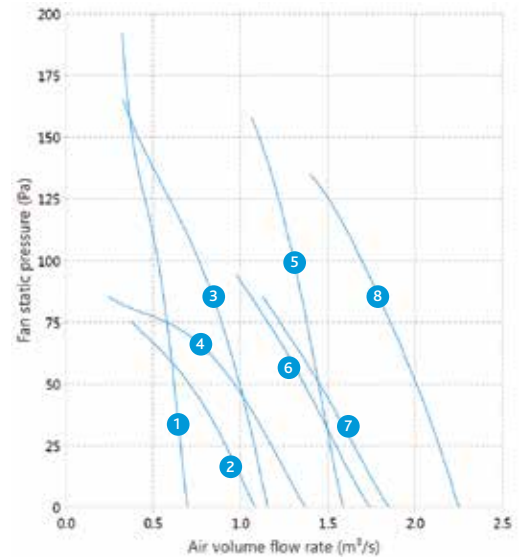
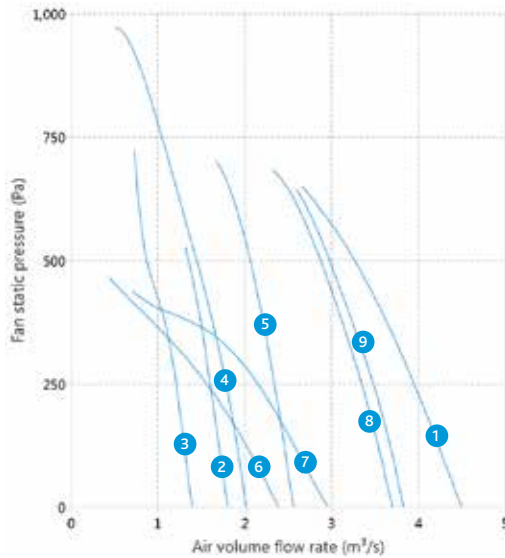

450mm Ø 2 POLE

CURVE	FAN CODE	BLADE ANGLE °	MOTOR RATING (KW)	RPM SPEED	MOTOR CURRENTS		SOUND POWER LEVELS RE 1 PWATT (Hz) INDUCT INLET								
					FLC	SC (DOL)	63	125	250	500	1K	2K	4K	8K	dB(A) @3M
1	AX45P-2	20	1.80	2852	3.67	18.36	85	85	86	91	91	87	83	81	57
2	AX45S-2	25	2.64	2845	5.28	30.8	88	88	89	92	93	90	85	81	60
3	AX45C-2	25	0.66	2760	1.70	8.52	80	83	88	82	82	78	73	70	53
4	AX45C-2	30	1.32	2846	2.92	14.58	86	95	94	88	86	80	75	72	56
5	AX45S-2	35	4.80	2890	9.05	56.55	90	91	92	95	93	89	85	81	60
6	AX45P-2	37.5	4.80	2890	9.05	56.55	91	90	91	93	91	86	81	76	57
7	AX45P-2	40	4.80	2910	8.83	51.52	92	91	89	90	90	85	80	75	57
8	AX45F-2	45	4.80	2910	8.83	51.52	88	90	84	90	89	85	82	79	57
9	AX45S-2	20	2.64	2860	5.45	35.87	89	89	89	93	94	90	85	81	59

450mm Ø 4 POLE

CURVE	FAN CODE	BLADE ANGLE °	MOTOR RATING (KW)	RPM SPEED	MOTOR CURRENTS		SOUND POWER LEVELS RE 1 PWATT (Hz) INDUCT INLET								
					FLC	SC (DOL)	63	125	250	500	1K	2K	4K	8K	dB(A) @3M
1	AX45S-4	20	0.30	1350	1.01	5.04	78	82	81	80	75	71	66	58	44
2	AX45A-4	25	0.14	1360	0.66	2.2	69	73	73	70	67	65	60	52	37
3	AX45D-4	25	0.14	1360	0.66	2.2	72	73	78	70	69	67	62	51	47
4	AX45A-4	30	0.14	1360	0.66	2.2	73	74	73	70	66	63	57	51	36
5	AX45P-4	32.5	0.44	1370	1.33	6.66	75	79	79	73	71	67	62	55	41
6	AX45C-4	35	0.30	1350	1.01	5.04	76	84	82	69	68	64	60	55	45
7	AX45C-4	40	0.30	1350	1.01	5.04	83	89	77	70	69	65	59	56	44
8	AX45D-4	45	0.66	1370	1.90	9.48	74	75	79	74	70	66	61	58	49

500mm Ø

2 POLE

4 POLE



Details illustrated are a small representation of the complete range. Please contact Nuair for selections specific to your project applications and/or request software download.

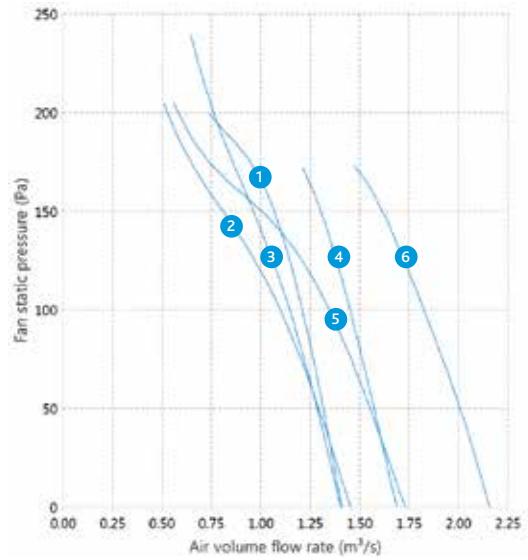
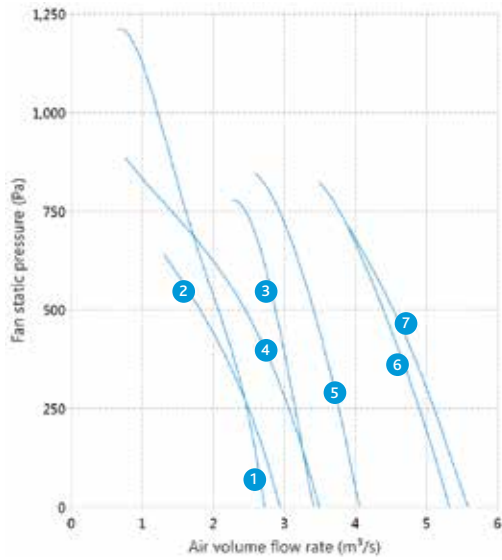

500mm Ø 2 POLE

CURVE	FAN CODE	BLADE ANGLE °	MOTOR RATING (KW)	RPM SPEED	FLC	SC (DOL)	MOTOR CURRENTS								dB(A) @3M
							63	125	250	500	1K	2K	4K	8K	
1	AX50P-2	20	3.60	2880	7.32	36.6	94	87	87	93	95	92	87	85	61
2	AX50D-2	25	1.80	2852	3.67	18.36	83	86	82	89	91	87	82	81	57
3	AX50O-2	25	2.64	2860	5.45	35.87	92	89	89	93	92	90	85	82	59
4	AX50S-2	30	6.60	2905	12.0	70	94	90	91	95	93	90	87	83	61
5	AX50S-2	35	9.00	2910	16.4	95.55	95	93	92	98	95	90	86	83	62
6	AX50P-2	40	9.00	2910	16.6	103.5	96	93	91	98	94	90	85	84	61
7	AX50P-2	45	9.00	2910	16.6	103.5	95	93	91	99	95	91	86	84	62

500mm Ø 4 POLE

CURVE	FAN CODE	BLADE ANGLE °	MOTOR RATING (KW)	RPM SPEED	FLC	SC (DOL)	MOTOR CURRENTS								dB(A) @3M
							63	125	250	500	1K	2K	4K	8K	
1	AX50O-4	20	0.30	1350	1.01	5.04	76	77	77	78	75	72	66	58	42
2	AX50P-4	20	0.44	1370	1.33	6.66	79	79	80	81	77	73	68	60	44
3	AX50S-4	25	0.44	1370	1.33	6.66	80	81	84	80	77	73	68	61	46
4	AX50S-4	30	0.66	1370	1.90	9.48	83	80	83	78	76	72	66	60	45
5	AX50P-4	32.5	0.90	1410	2.80	13.98	80	78	80	75	73	70	64	58	43
6	AX50F-4	35	0.66	1370	1.90	9.48	85	78	86	82	76	73	67	61	49

560mm Ø

2 POLE

4 POLE



Details illustrated are a small representation of the complete range. Please contact Nuair for selections specific to your project applications and/or request software download.

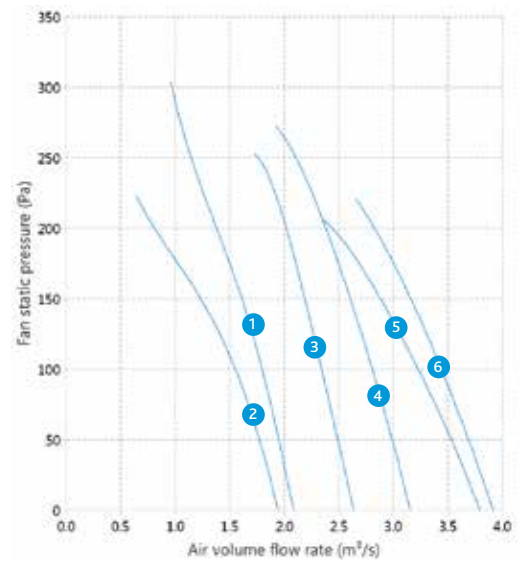
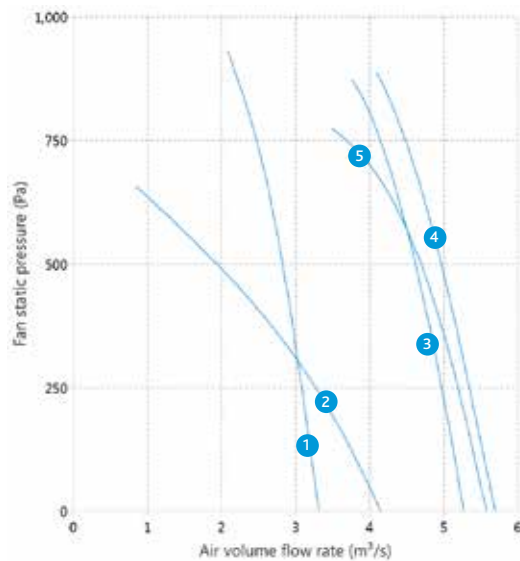

560mm Ø 2 POLE

CURVE	FAN CODE	BLADE ANGLE °	MOTOR RATING (kW)	RPM SPEED	MOTOR CURRENTS		SOUND POWER LEVELS RE 1 PWATT (Hz) INDUCT INLET								
					FLC	SC (DOL)	63	125	250	500	1K	2K	4K	8K	dB(A) @3M
1	AX56S-2	20	6.60	2900	12.2	76.5	88	92	0	98	96	93	89	86	63
2	AX56E-2	25	2.64	2845	5.28	30.8	85	83	92	92	89	86	81	79	57
3	AX56P-2	30	9.00	2910	16.4	95.55	98	95	92	101	95	91	89	85	63
4	AX56P-2	32.5	9.00	2910	16.6	103.5	98	97	93	101	95	91	90	85	63
5	AX56F-2	35	9.00	2910	16.6	103.5	92	93	91	102	101	96	92	86	67

560mm Ø 4 POLE

CURVE	FAN CODE	BLADE ANGLE °	MOTOR RATING (kW)	RPM SPEED	MOTOR CURRENTS		SOUND POWER LEVELS RE 1 PWATT (Hz) INDUCT INLET								
					FLC	SC (DOL)	63	125	250	500	1K	2K	4K	8K	dB(A) @3M
1	AX56P-4	20	0.66	1370	1.90	9.48	83	82	84	84	81	77	72	64	48
2	AX56F-4	25	0.30	1350	1.01	5.04	71	75	76	75	75	74	74	61	45
3	AX56S-4	30	1.32	1425	2.90	14.52	74	78	76	82	81	77	74	72	48
4	AX56S-4	35	1.32	1425	2.90	14.52	75	78	76	83	80	76	73	69	48
5	AX56O-4	40	1.32	1420	3.00	16.75	88	84	84	80	79	73	66	62	46
6	AX56AA-4	45	2.64	1440	5.88	34.3	81	82	82	83	79	76	72	67	50

630mm Ø

2 POLE

4 POLE



Details illustrated are a small representation of the complete range. Please contact Nuairé for selections specific to your project applications and/or request software download.

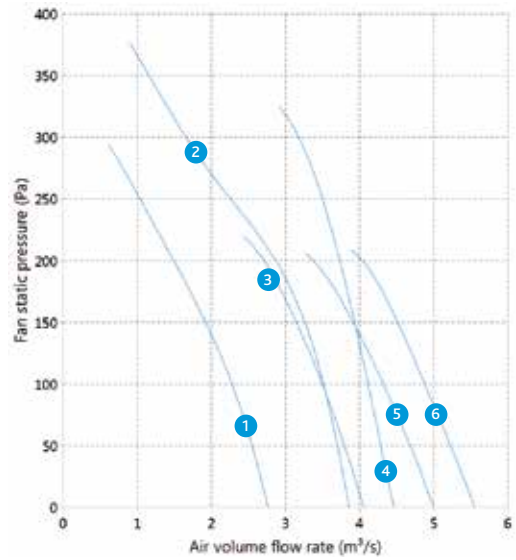
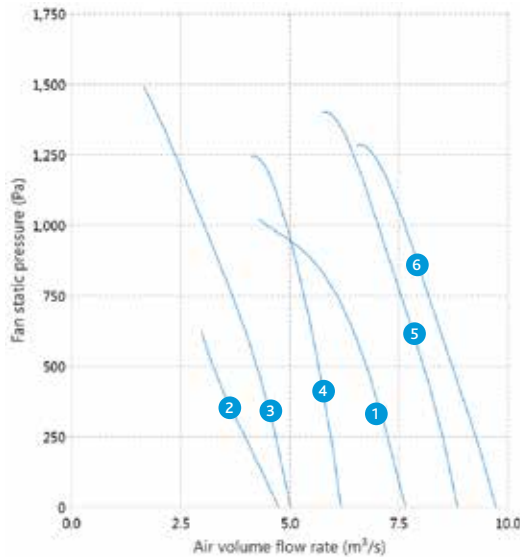

630mm Ø 2 POLE

CURVE	FAN CODE	BLADE ANGLE °	MOTOR RATING (KW)	RPM SPEED	FLC	SC (DOL)	MOTOR CURRENTS								SOUND POWER LEVELS RE 1 PWATT (Hz) INDUCT INLET				dB(A) @3M
							63	125	250	500	1K	2K	4K	8K	63	125	250	500	
1	AX63P-2	20	9.00	2910	16.38	95.55	88	86	89	97	99	98	92	89	66				
2	AX63AD-2	25	13.20	2920	23.21	152.79	92	92	93	101	102	98	93	91	66				
3	AX63P-2	30	11.04	2910	20.16	126	95	101	96	100	98	94	91	88	65				
4	AX63N-2	32.5	4.80	2890	9.05	56.55	97	108	94	100	97	90	89	86	63				
5	AX63AD-2	35	22.20	2940	39.12	244.5	96	98	99	107	100	95	92	88	68				
6	AX63AD-2	40	26.40	2950	46.32	289.5	100	99	98	107	100	96	93	88	69				

630mm Ø 4 POLE

CURVE	FAN CODE	BLADE ANGLE °	MOTOR RATING (KW)	RPM SPEED	FLC	SC (DOL)	MOTOR CURRENTS								SOUND POWER LEVELS RE 1 PWATT (Hz) INDUCT INLET				dB(A) @3M
							63	125	250	500	1K	2K	4K	8K	63	125	250	500	
1	AX63P-4	30	1.32	1425	2.90	14.52	87	82	86	84	80	78	74	66	50				
2	AX63O-4	30	1.32	1425	2.90	14.52	93	88	86	83	80	77	73	66	51				
3	AX63AD-4	35	3.60	1430	7.40	49.36	84	85	88	85	80	77	74	67	51				
4	AX63O-4	40	1.80	1420	3.97	19.26	94	89	86	84	81	78	74	69	50				
5	AX63Z-4	45	2.64	1440	5.88	34.2	90	89	88	86	83	80	77	72	52				
6	AX63O-4	20	0.90	1420	2.08	10.38	90	85	85	83	80	76	71	63	48				



For High Pressure Axials refer to pages 30 & 31.

710mm Ø

4 POLE

6 POLE



Details illustrated are a small representation of the complete range. Please contact Nuair for selections specific to your project applications and/or request software download.

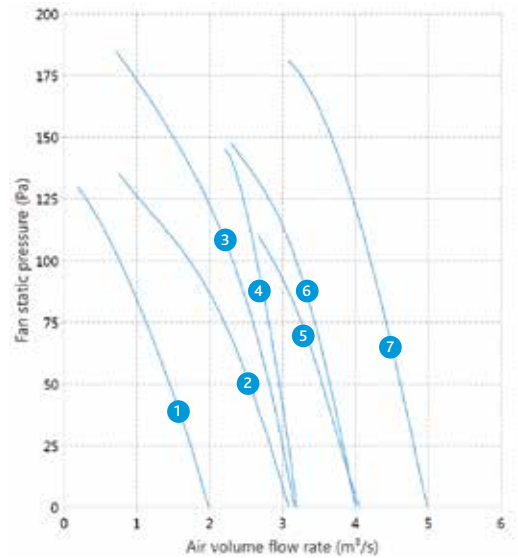
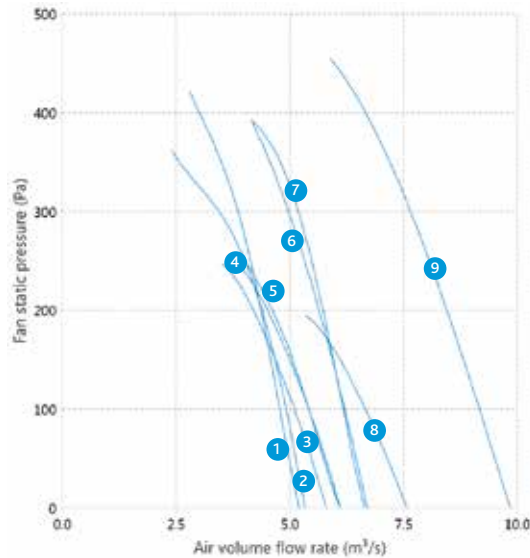

710mm Ø 4 POLE

CURVE	FAN CODE	BLADE ANGLE °	MOTOR RATING (kW)	RPM SPEED	MOTOR CURRENTS		SOUND POWER LEVELS RE 1 PWATT (Hz) INDUCT INLET								
					FLC	SC (DOL)	63	125	250	500	1K	2K	4K	8K	dB(A) @3M
1	AX71DG-4	25	3.60	1440	7.60	49.37	86	85	86	83	81	73	69	63	44
2	AX71P-4	30	1.80	1420	3.97	23.86	81	79	85	85	85	82	81	75	48
3	AX71O-4	30	1.80	1420	3.97	23.86	88	92	89	85	82	80	77	70	49
4	AX71O-4	32.5	2.64	1440	5.88	34.3	90	93	89	86	82	80	77	71	49
5	AX71O-4	35	2.64	1430	5.36	26.82	87	83	84	83	82	78	77	71	45
6	AX71S-4	37.5	4.80	1435	9.9	66	93	92	88	89	86	81	76	71	48
7	AX71AA-4	40	3.60	1440	7.60	49.37	84	84	94	90	86	83	80	72	52
8	AX71O-4	45	4.80	1440	9.88	61.73	94	92	88	88	85	84	78	74	50
9	AX71AD-4	50	9.00	1450	17.4	108.75	88	86	93	90	87	84	80	76	53

710mm Ø 6 POLE

CURVE	FAN CODE	BLADE ANGLE °	MOTOR RATING (kW)	RPM SPEED	MOTOR CURRENTS		SOUND POWER LEVELS RE 1 PWATT (Hz) INDUCT INLET								
					FLC	SC (DOL)	63	125	250	500	1K	2K	4K	8K	dB(A) @3M
1	AX71O-6	20	0.44	890	1.48	4.92	74	78	79	76	76	72	66	57	38
2	AX71O-6	25	0.44	890	1.48	4.92	74	77	79	72	72	70	66	57	37
3	AX71P-6	25	0.44	890	1.48	4.92	75	82	76	74	74	72	67	58	38
4	AX71AG-6	30	0.90	935	2.17	10.86	81	81	82	80	77	75	68	61	42
5	AX71O-6	35	0.66	900	1.98	6.6	82	81	78	78	74	70	66	59	37
6	AX71P-6	32.5	0.90	925	2.41	9.45	75	79	73	76	73	70	67	58	35
7	AX71AD-6	40	1.32	935	2.94	14.7	79	79	78	77	73	71	65	58	39



For High Pressure Axials refer to pages 30 & 31.

800mm Ø

4 POLE

6 POLE



Details illustrated are a small representation of the complete range. Please contact Nuairé for selections specific to your project applications and/or request software download.

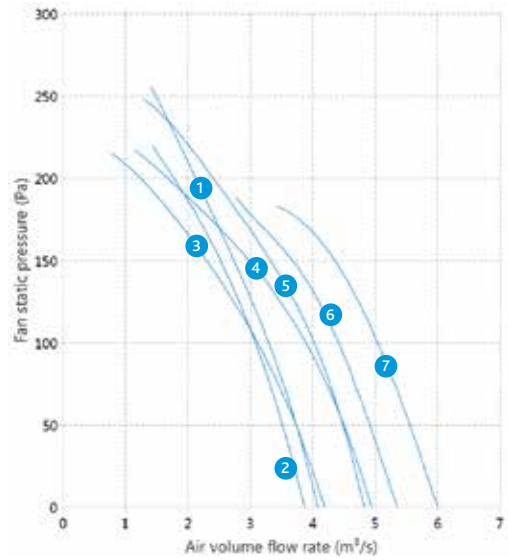
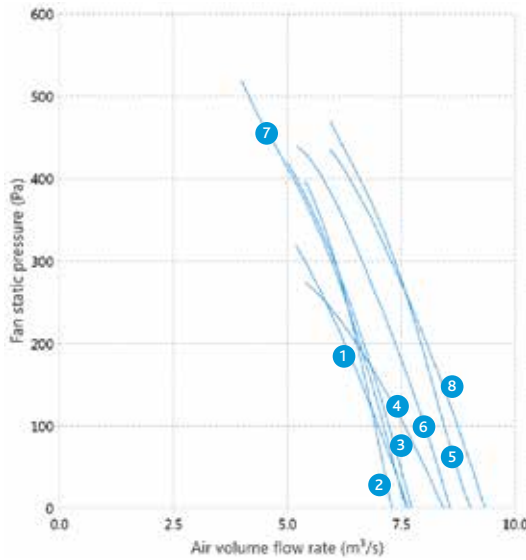

800mm Ø 4 POLE

CURVE	FAN CODE	BLADE ANGLE °	MOTOR RATING (KW)	RPM SPEED	FLC	SC (DOL)	MOTOR CURRENTS								dB(A) @3M
							63	125	250	500	1K	2K	4K	8K	
1	AX80DG-4	25	4.80	1440	9.88	61.73	86	96	92	88	85	78	74	68	50
2	AC80AG-4	30	6.60	1430	13.09	87.28	89	86	91	93	89	86	85	78	52
3	AC80DG-4	30	4.80	1435	9.90	66	88	95	93	89	86	79	75	70	50
4	AX80P-4	32.5	4.80	1435	9.90	66	86	89	94	91	87	84	80	73	53
5	AX80S-4	32.5	9.00	1430	17.32	115.44	91	96	93	93	89	85	82	74	50
6	AX80S-4	35	9.00	1450	17.4	108.75	97	96	92	92	89	84	80	75	53
7	AX80O-4	37.5	4.80	1440	9.88	61.73	96	94	93	91	87	86	81	76	52
8	AX80S-4	40	9.00	1430	17.32	115.44	94	96	95	94	90	86	82	78	53

800mm Ø 6 POLE

CURVE	FAN CODE	BLADE ANGLE °	MOTOR RATING (KW)	RPM SPEED	FLC	SC (DOL)	MOTOR CURRENTS								dB(A) @3M
							63	125	250	500	1K	2K	4K	8K	
1	AX80DG-6	20	0.66	900	1.98	6.6	85	89	81	79	73	67	62	54	40
2	AX80AA-6	25	0.90	925	2.41	9.45	75	88	80	82	80	75	70	60	44
3	AX80P-6	25	0.90	935	2.17	10.86	72	82	75	77	76	75	71	60	40
4	AX80AA-6	30	0.90	925	2.41	9.45	73	82	79	76	75	74	69	58	40
5	AX80AG-6	30	2.64	940	5.65	28.26	81	82	85	83	79	77	71	62	45
6	AX80AA-6	32.5	1.32	930	3.38	14.1	82	95	86	84	79	75	70	61	47
7	AX80P-6	45	1.32	935	2.94	14.7	86	89	83	83	78	75	70	62	45



For High Pressure Axials refer to pages 30 & 31.

900mm Ø

4 POLE

6 POLE



Details illustrated are a small representation of the complete range. Please contact Nuairé for selections specific to your project applications and/or request software download.

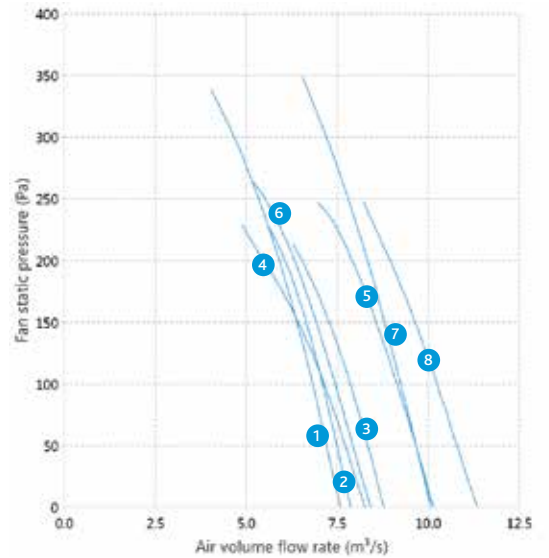
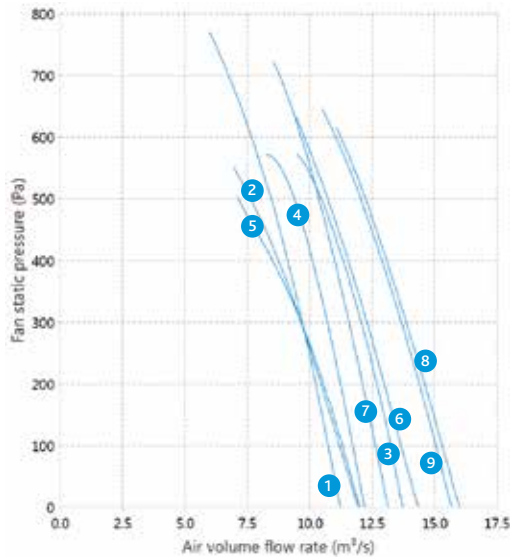

900mm Ø 4 POLE

CURVE	FAN CODE	BLADE ANGLE °	MOTOR RATING (KW)	RPM SPEED	MOTOR CURRENTS		SOUND POWER LEVELS RE 1 PWATT (Hz) INDUCT INLET								
					FLC	SC (DOL)	63	125	250	500	1K	2K	4K	8K	dB(A) @3M
1	AX90DJ-4	25	11.04	1450	23.52	147	93	93	98	97	89	83	80	75	57
2	AX90DH-4	30	9.00	1430	17.32	115.44	98	109	96	93	89	84	82	80	58
3	AX90DJ-4	30	11.04	1450	23.52	147	98	97	100	98	91	85	83	78	59
4	AX90AG-4	35	18.00	1445	30.66	201.85	94	91	95	97	94	91	88	81	58
5	AX90DG-4	35	11.04	1450	23.52	147	98	100	97	96	92	87	84	81	56
6	AX90AA-4	37.5	9.00	1450	17.40	108.75	92	87	96	98	97	93	88	82	61
7	AX90AG-4	40	18.00	1450	34.08	213	96	94	101	99	95	92	88	82	59
8	AX90DG-4	40	18.00	1450	34.08	213	99	101	98	96	93	88	86	84	57
9	AX90AG-4	45	22.20	1445	39.78	261.89	97	94	96	97	93	89	85	80	57

900mm Ø 6 POLE

CURVE	FAN CODE	BLADE ANGLE °	MOTOR RATING (KW)	RPM SPEED	MOTOR CURRENTS		SOUND POWER LEVELS RE 1 PWATT (Hz) INDUCT INLET								
					FLC	SC (DOL)	63	125	250	500	1K	2K	4K	8K	dB(A) @3M
1	AX90DJ-6	25	3.60	960	8.21	38.99	87	89	89	88	79	73	68	61	49
2	AX90DG-6	30	3.60	940	7.31	36.54	89	89	88	87	81	74	70	64	46
3	AX90AG-6	35	3.60	940	7.31	36.54	84	86	91	85	83	82	77	69	50
4	AX90DJ-6	35	6.60	945	13.2	66	92	94	93	88	82	77	73	67	52
5	AX90AA-6	37.5	2.64	945	6.20	28.44	85	89	86	89	87	84	78	69	51
6	AX90AG-6	40	4.80	945	9.50	47.52	85	84	88	84	81	80	75	68	48
7	AX90AG-6	45	6.60	945	13.2	66	89	88	90	87	83	79	75	70	50
8	AX90AG-6	50	13.20	970	27.5	171.75	92	87	92	88	85	82	78	72	51



For High Pressure Axials refer to pages 30 & 31.

1000mm Ø

4 POLE

6 POLE



Details illustrated are a small representation of the complete range. Please contact Nuair for selections specific to your project applications and/or request software download.

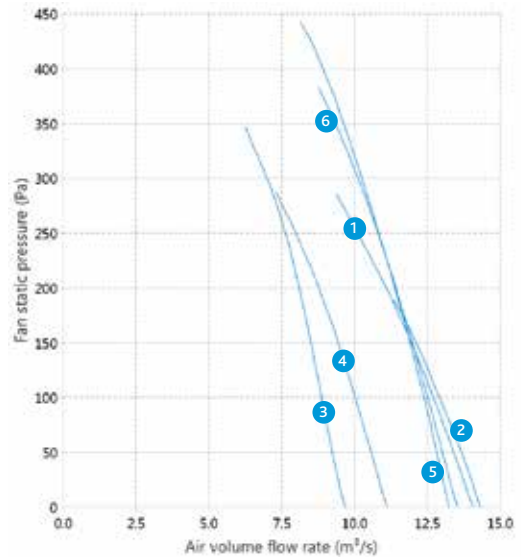
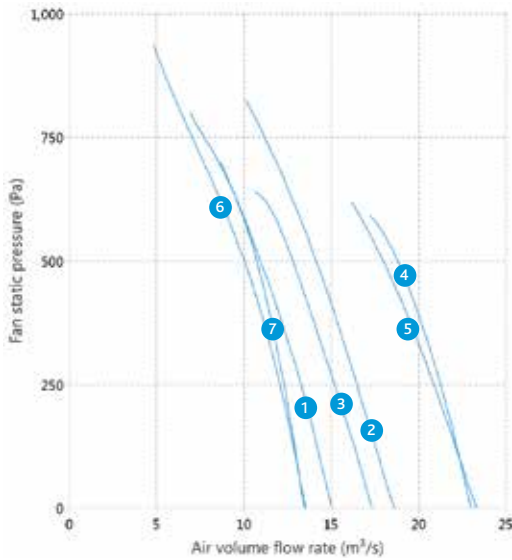

1000mm Ø 4 POLE

CURVE	FAN CODE	BLADE ANGLE °	MOTOR RATING (KW)	RPM SPEED	FLC	SC (DOL)	MOTOR CURRENTS								dB(A) @3M
							63	125	250	500	1K	2K	4K	8K	
1	AX100CZ-4	45	44.40	1470	85.31	561.61	103	103	112	103	97	94	94	91	69
2	AX100AG-4	50	44.40	1470	85.31	561.61	100	102	97	101	101	98	95	90	63
3	AX100DB-4	25	18.00	1445	30.66	201.85	99	101	103	99	94	90	88	84	61
4	AX100DJ-4	25	13.20	1440	22.91	150.81	100	104	107	106	98	92	89	85	66
5	AX100AG-4	30	18.00	1450	34.08	213	95	100	106	10	102	96	91	85	65
6	AX100CX-4	30	18.00	1445	30.66	201.85	100	103	104	101	95	90	89	86	62
7	AX100CY-4	35	22.20	1445	39.78	261.89	108	116	103	101	94	90	91	89	64

1000mm Ø 6 POLE

CURVE	FAN CODE	BLADE ANGLE °	MOTOR RATING (KW)	RPM SPEED	FLC	SC (DOL)	MOTOR CURRENTS								dB(A) @3M
							63	125	250	500	1K	2K	4K	8K	
1	AX100CZ-6	35	9.00	955	17.35	108.45	92	91	95	94	87	82	78	71	55
2	AX100DJ-6	35	6.60	945	13.2	66	95	95	96	92	86	81	78	72	67
3	AX100CZ-6	41	9.00	970	19.32	120.75	98	98	105	95	87	85	84	79	63
4	AX100DL-6	45	13.20	970	27.48	171.75	100	98	10	96	90	87	86	82	58
5	AX100CZ-6	25	6.60	960	14.4	90	92	94	94	93	86	81	77	72	54
6	AX100CZ-6	30	6.60	960	14.4	90	94	97	102	91	83	80	78	73	59

1120mm Ø

4 POLE

6 POLE



Details illustrated are a small representation of the complete range. Please contact Nuair for selections specific to your project applications and/or request software download.

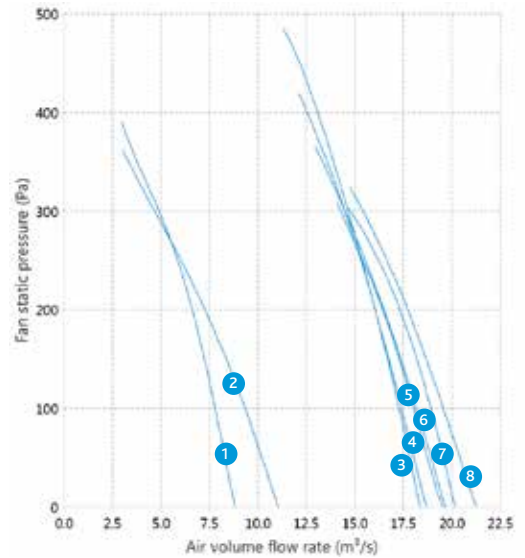
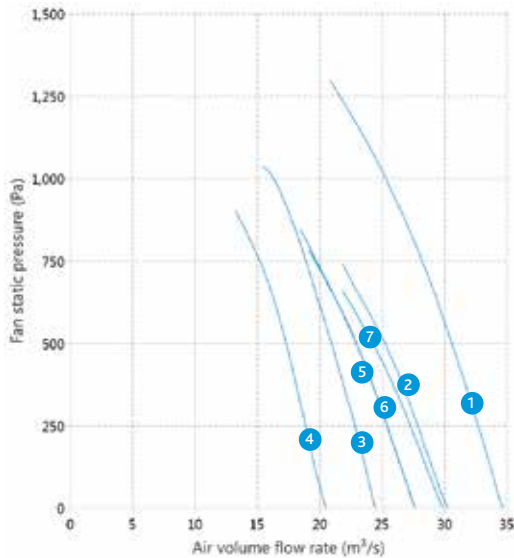

1120mm Ø 4 POLE

CURVE	FAN CODE	BLADE ANGLE °	MOTOR RATING (KW)	RPM SPEED	MOTOR CURRENTS		SOUND POWER LEVELS RE 1 PWATT (Hz) INDUCT INLET								
					FLC	SC (DOL)	63	125	250	500	1K	2K	4K	8K	dB(A) @3M
1	AX112DL-4	35	44.40	1470	85.31	561.61	104	103	107	105	100	96	96	94	66
2	AX112CZ-4	35	54.00	1480	104.65	654.08	101	102	109	102	98	95	94	91	67
3	AX112DJ-4	40	54.00	1480	104.65	654.08	104	104	108	107	102	98	97	95	69
4	AX112DL-4	40	54.00	1480	103.43	680.90	105	103	108	106	101	98	98	96	67
5	AX112CZ-4	45	66.00	1480	114.42	753.27	107	103	108	110	103	98	97	94	70
6	AX112CZ-4	30	36.00	1470	66.24	414	103	102	106	105	97	94	94	90	66
7	AX112CZ-4	25	26.40	1460	46.04	303.12	99	101	106	105	97	93	91	87	66

1120mm Ø 6 POLE

CURVE	FAN CODE	BLADE ANGLE °	MOTOR RATING (KW)	RPM SPEED	MOTOR CURRENTS		SOUND POWER LEVELS RE 1 PWATT (Hz) INDUCT INLET								
					FLC	SC (DOL)	63	125	250	500	1K	2K	4K	8K	dB(A) @3M
1	AX122CZ-6	35	13.20	960	24.83	155.18	94	93	97	96	89	85	80	75	57
2	AX112DJ-6	35	9.00	970	19.32	120.75	97	97	99	94	89	85	81	75	58
3	AX112DL-6	40	18.00	960	34.68	216.75	101	99	104	99	92	89	88	85	61
4	AX112CZ-6	40	13.20	970	27.48	171.75	101	100	106	99	91	88	88	82	64
5	AX112CZ-6	45	18.00	960	34.68	216.75	103	100	106	100	91	89	90	87	65
6	AX112AG-6	45	18.00	960	34.68	216.75	93	94	91	96	92	88	84	74	54
7	AX112DG-6	20	3.60	940	7.31	36.54	90	98	93	96	90	85	82	79	54
8	AX112AD-6	25	3.60	940	7.31	36.54	83	91	94	94	92	86	82	68	54

1250mm Ø

4 POLE

6 POLE



Details illustrated are a small representation of the complete range. Please contact Nuair for selections specific to your project applications and/or request software download.

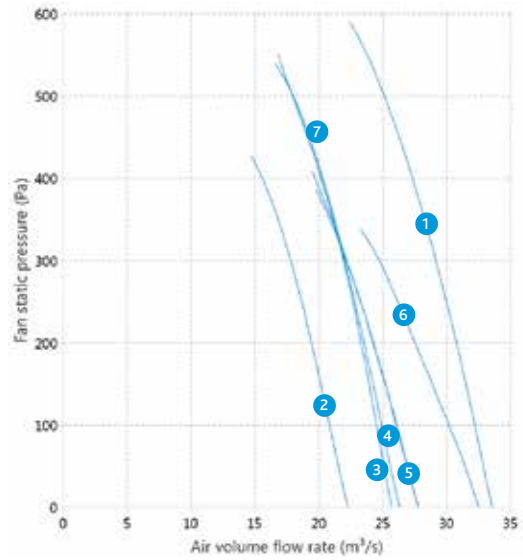
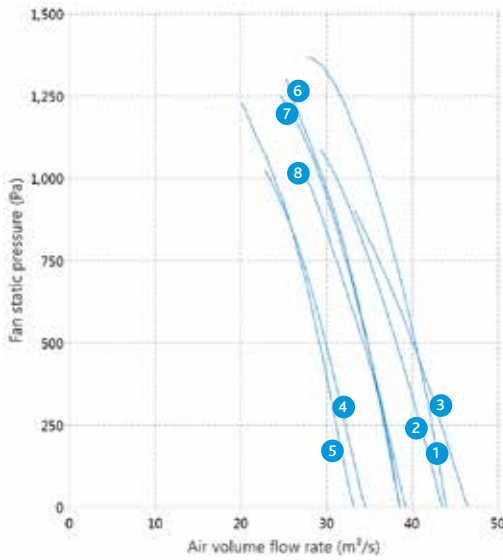

1250mm Ø 4 POLE

CURVE	FAN CODE	BLADE ANGLE °	MOTOR RATING (KW)	RPM SPEED	FLC	SC (DOL)	MOTOR CURRENTS								SOUND POWER LEVELS RE 1 PWATT (Hz) INDUCT INLET				dB(A) @3M
							63	125	250	500	1K	2K	4K	8K	63	125	250	500	
1	AS125CZ-4	35	66.00	1480	115.79	723.68	100	100	109	109	101	98	97	91	68				
2	AX125DL-4	35	90.00	1480	151.87	949.2	104	101	111	107	103	100	99	96	72				
3	AX125DB-4	40	90.00	1480	150.26	989.24	107	111	107	107	101	97	96	96	67				
4	AX125DL-4	40	90.00	1480	150.26	989.24	108	104	112	109	105	102	101	99	74				
5	AX125CZ-4	45	108.00	1480	177.98	1171.73	106	106	112	109	103	101	100	98	71				
6	AX125DB-4	30	54.00	1480	104.65	654.08	104	108	113	114	108	101	95	90	72				
7	AX125DL-4	30	44.40	1470	85.31	561.61	104	101	111	110	104	99	98	94	72				
8	AX125DB-4	35	90.00	1480	151.87	949.2	105	105	108	105	101	97	94	92	67				

1250mm Ø 6 POLE

CURVE	FAN CODE	BLADE ANGLE °	MOTOR RATING (KW)	RPM SPEED	FLC	SC (DOL)	MOTOR CURRENTS								SOUND POWER LEVELS RE 1 PWATT (Hz) INDUCT INLET				dB(A) @3M
							63	125	250	500	1K	2K	4K	8K	63	125	250	500	
1	AX125DL-6	35	22.20	965	41.11	256.95	97	700	102	99	94	90	89	84	60				
2	AX125CZ-6	35	18.00	960	34.32	214.5	95	98	100	98	93	87	83	76	58				
3	AX125DL-6	40	26.40	965	48.06	300.38	102	102	106	102	95	92	91	90	67				
4	AX125CZ-6	40	26.40	965	48.74	304.65	103	102	106	102	93	91	90	88	64				
5	AX125CZ-6	45	36.00	975	66.67	416.7	102	104	102	101	97	91	88	86	62				
6	AX125CZ-6	50	36.00	975	65.81	411.3	99	106	99	96	95	90	89	85	59				
7	AX125DB-6	30	18.00	960	34.32	214.5	100	99	102	96	91	87	84	81	59				

1400mm Ø

6 POLE

1500mm Ø

6 POLE



Details illustrated are a small representation of the complete range. Please contact Nuair for selections specific to your project applications and/or request software download.

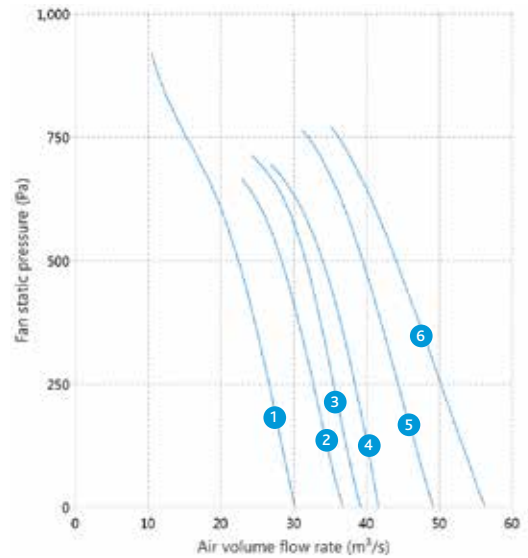
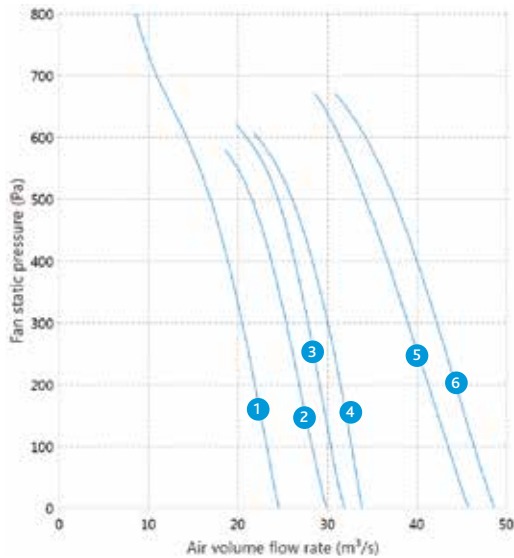

1400mm Ø 6 POLE

CURVE	FAN CODE	BLADE ANGLE °	MOTOR RATING (KW)	RPM SPEED	MOTOR CURRENTS		SOUND POWER LEVELS RE 1 PWATT (Hz) INDUCT INLET								
					FLC	SC (DOL)	63	125	250	500	1K	2K	4K	8K	dB(A) @3M
1	AX140DB-6	25	13.20	960	24.83	155.18	100	94	97	98	101	98	93	87	61
2	AX140DB-6	30	22.20	965	42.31	256.95	98	96	103	103	101	96	91	85	61
3	AX140DB-6	32.5	22.20	965	42.31	256.95	96	102	103	100	99	95	93	87	63
4	AX140DB-6	35	26.40	965	48.06	300.38	100	105	104	102	98	93	89	83	65
5	AX140DB-6	45	54.00	980	96.73	604.58	103	100	105	106	102	99	96	90	63
6	AX140DB-6	50	54.00	980	96.73	604.58	105	104	112	109	104	101	97	91	67

1500mm Ø 6 POLE

CURVE	FAN CODE	BLADE ANGLE °	MOTOR RATING (KW)	RPM SPEED	MOTOR CURRENTS		SOUND POWER LEVELS RE 1 PWATT (Hz) INDUCT INLET								
					FLC	SC (DOL)	63	125	250	500	1K	2K	4K	8K	dB(A) @3M
1	AX150DB-6	25	18.00	960	34.68	216.75	102	97	99	100	103	101	95	89	63
2	AX150DB-6	30	36.00	975	65.81	411.3	100	98	106	105	103	98	94	87	63
3	AX150DB-6	32.5	36.00	975	65.81	411.3	98	104	105	102	101	97	95	89	65
4	AX150DB-6	35	36.00	975	65.81	411.3	102	107	106	104	100	95	91	85	67
5	AX150DB-6	40	54.00	980	96.73	604.58	103	100	105	107	104	103	99	92	64
6	AX150DB-6	45	66.00	980	118.98	743.63	105	102	107	108	105	101	98	92	65

1600mm Ø

6 POLE



Details illustrated are a small representation of the complete range. Please contact Nuairé for selections specific to your project applications and/or request software download.

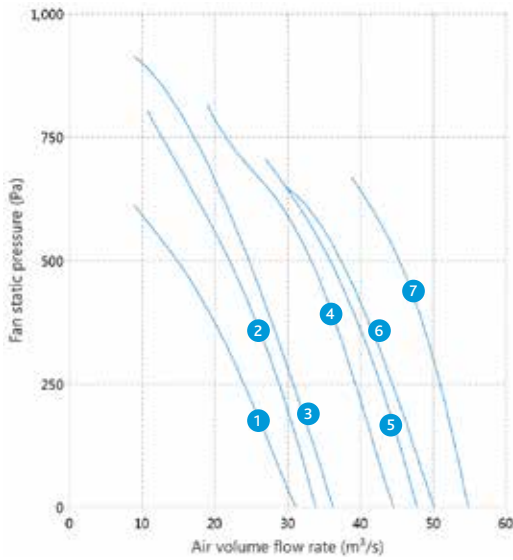

1600mm Ø 6 POLE

CURVE	FAN CODE	BLADE ANGLE °	MOTOR RATING (kW)	RPM SPEED	MOTOR CURRENTS		SOUND POWER LEVELS RE 1 PWATT (Hz) INDUCT INLET								
					FLC	SC (DOL)	63	125	250	500	1K	2K	4K	8K	dB(A) @3M
1	AX160CX-6	25	13.20	970	27.48	171.75	93	104	100	101	98	93	90	84	62
2	AX160CZ-6	25	18.00	960	34.32	214.5	90	102	100	101	97	92	91	87	62
3	AX160DB-6	25	22.20	975	42.72	267	91	103	100	101	97	92	92	91	62
4	AX160DB-6	30	44.40	975	83.75	523.43	95	105	106	106	101	95	95	93	67
5	AX160DB-6	32	54.00	980	97.78	611.1	97	106	109	108	103	96	95	92	69
6	AX160CZ-6	35	54.00	980	97.78	611.1	98	109	110	109	103	96	95	93	70
7	AX160DB-6	40	66.00	980	117.72	735.75	113	117	109	104	98	97	96	91	66

We can help.

For selections requiring a unit size greater than 1600mm diameter, please contact Nuairé for your fan selections tailored to your project and applications requirements.

The curves shown in this catalogue are not limited only to the products shown here, and show a small selection of the capabilities of Nuairé.

For additional selections, please contact Nuairé on +44(0)29 2085 8484, or download the selection software from www.nuairegroup.com



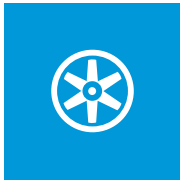

AXUS ANCILLARIES

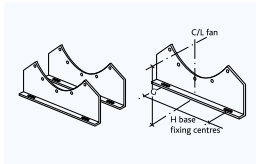

MOUNTING BRACKETS*

The AXUS mounting brackets are manufactured from heavy gauge galvanised steel and are supplied in pairs.

Typical Code - CMB100
(100 = Fan diameter in cm).

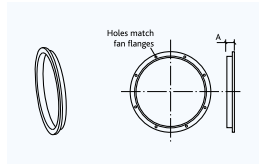

MATCHING FLANGE (SINGLE)*

Manufactured from galvanised steel. Matching flanges are supplied individually.

Typical Code: CMF100
(100 = fan diameter in cm).

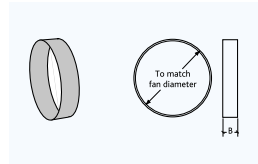

FLEXIBLE CONNECTOR (SINGLE)*

Circular without flanges. Flexible duct material is flameproof and resistant to heat up to 132°C/400°C, chemicals, ozone, oil and grease. The material is airtight, waterproof and tested to BS476 Part 7. (Supplied complete with fixing straps).

Typical Code: CFC100
(100 = fan diameter in cm) - 132°C. **CFCH100** (100 = fan diameter in cm) - 400°C.

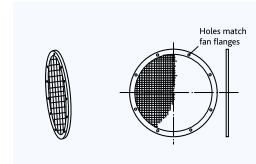

GUARD*

Manufactured from heavy gauge galvanised steel and acid zinc plated steel mesh. Standard Accessory Losses (k). Flat type • Finger guard 0.4.

Typical Code: CGD100
(100 = fan diameter in cm). Pressure Drop (Pa) = 0.6 x k x Velocity (m/s).

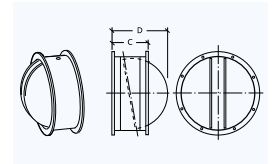

BACKDRAUGHT DAMPER (SINGLE)*

Gravity operated backdraught damper, manufactured from heavy gauge galvanised steel with a pair of bolted flanges. Standard Accessory Losses (k) (Air stream operated) 0.4.

Typical Code: CBD100
(100 = fan diameter in cm) - 132°C. (For horizontal mounting only). Pressure Drop (Pa) = 0.6 x k x Velocity (m/s).

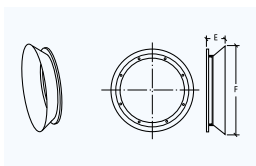

INLET CONE*

Manufactured in heavy gauge galvanised steel with a single bolted flange. Standard Accessory Losses (k). Low loss • Inlet cone 0.38.

Typical Code: CIC100
(100 = fan diameter in cm). Pressure Drop (Pa) = 0.6 x k x Velocity (m/s).

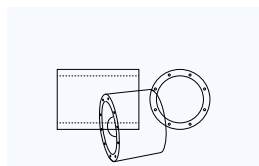

ATTENUATOR*

Standard (non podded), long (non podded), and long podded options available. Conical Inlet silencer available upon request.

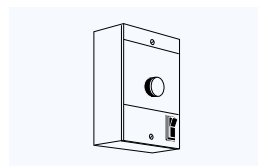

CONTROLS*

Choice of inverter, electronic or transformer speed controls available.

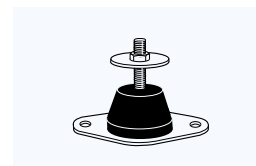

ANTI-VIBRATION MOUNTS*

Resilient rubber, for fan only. Spring options also available.

Typical code: NAV1.

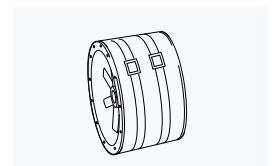

ACOUSTIC JACKET*

Acoustic material laminated with 25mm foam. Complete with straps/buckles for security.

*For dimensional information, please contact Nuairé.



HIGH TEMPERATURE AND AMBIENT HIGH PRESSURE AXIAL RANGE

The AXUS high pressure range of axial flow fans are designed for 'in-duct' applications. Manufactured from mild steel and then galvanised, making the unit suitable for indoor and outdoor applications.



KEY BENEFITS:

- **HOT DIPPED GALVANISED STEEL CONSTRUCTION** - ENSURING STRENGTH, DURABILITY & PROTECTION
- **HIGH PERFORMANCE** - DUTY UP TO 25M³/S WITH PRESSURE UP TO 2000 PA
- **HIGH TEMPERATURE** - INDEPENDENTLY TESTED TO EN12101-3
- **FLEXIBLE SOLUTION** - SUITABLE FOR INTERNAL & EXTERNAL APPLICATIONS, & VERTICALLY OR HORIZONTALLY
- **TESTED TO HIGHEST STANDARDS** - AIR PERFORMANCE TO ISO 5801 (PART 1) 2017
- **AMCA APPROVED LABS** - BOTH TYPE 'A' & 'D' LABORATORIES AT NUAIRE ARE ACCREDITED TO THE AMCA 300 STANDARD





CONSULTANT SPECIFICATION



CASING

Long cased covering both the motor and impeller, manufactured from heavy gauge galvanised steel (HDG), corrosion resistant to BS EN10142 1991 with integral formed inlet and outlet mounting flange, with pre-drilled bolt holes.

Cases are fitted with integral case mounted guide vanes– providing performance-enhancing characteristics.

Case material options available:

- HDG as standard
- Painted: Polyester Powder or Epoxy



PERFORMANCE

Up to 25m³/s duty range, 2000 Pa.



CERTIFICATION AND OPERATING TEMPERATURE

Suitable for day to day environmental extract up to a maximum of 60°C.



MOTOR

Motors incorporated are TEFC (Totally Enclosed Fan Cooled) type of an aluminium or cast iron (dependent on frame size) construction, protected with a paint finish. Protected to IP55 with Class F insulation. Available in both single and three phase supply (50/60Hz).

Motors incorporate integral PTC Thermistors, as standard, ensuring thermal overload protection during the life cycle of the motor.

Motors are suitable for speed control by frequency inverters, subject to fan selection.

There are many other motor options available specific for your project requirements such as:

- IE1, IE2, IE3 and IE4 Efficiency Classes
- 2 speed (Full/Half and Full/Two Thirds)
- 60Hz: Specific to your voltage requirements

Please contact Nuaire or download selection software for the complete range.



ANCILLARIES

- Matching flanges
- Flexible connections
- Anti-vibration mounts
- Mounting brackets (additional if required)
- Acoustic jackets
- Attenuators
- Guards
- Inlet cones
- Backdraught dampers
- Controls



IMPELLER

For all temperature classes, ambient, 300°C and 400°C for 2hr, impellers are high efficiency profile, fabricated completely from mild steel mounted in a steel hub ensuring optimum performance and safety under emergency conditions.



INSTALLATION

Suitable for internal and external operation. The unit should be installed horizontally on the mounting feet as supplied. For alternative mounting arrangements, contact Nuaire. DW/144 and general good practice standards for installation should be taken into consideration at design stage.



APPLICATIONS

- Utility tunnel & service room
- Car parks & smoke
- Industrial
- Boiler rooms
- Lift motor rooms
- Utility & transit tunnels
- Sports halls
- Factories & warehouses
- Hospitals & medical centres
- Offices & commercial
- Supermarkets
- Retail, leisure & sports facilities
- Public buildings



AXIAL - HIGH PRESSURE SINGLE STAGE

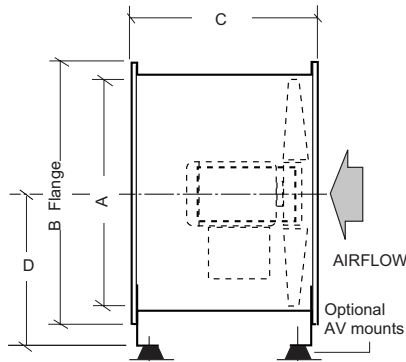

CODING AX63X-XX

AX	63	X	-	X	X
1	2	3	4	5	

SAMPLE CODING

1. Axial fan
2. Size of casing in CM
3. Impeller specification reference
4. Motor speed in poles
5. Operating temperature reference

Contact Nuair for Fan Selector to help in selecting the right unit for your project.

DIMENSIONS (MM)

MODEL	A	B	C	D
AX630	630	740	840	488
AX710	707	817	840	564
AX710	707	817	1043	564
AX800	808	918	840	590
AX800	808	918	1043	590
AX900	909	1019	840	659
AX900	909	1019	1043	659

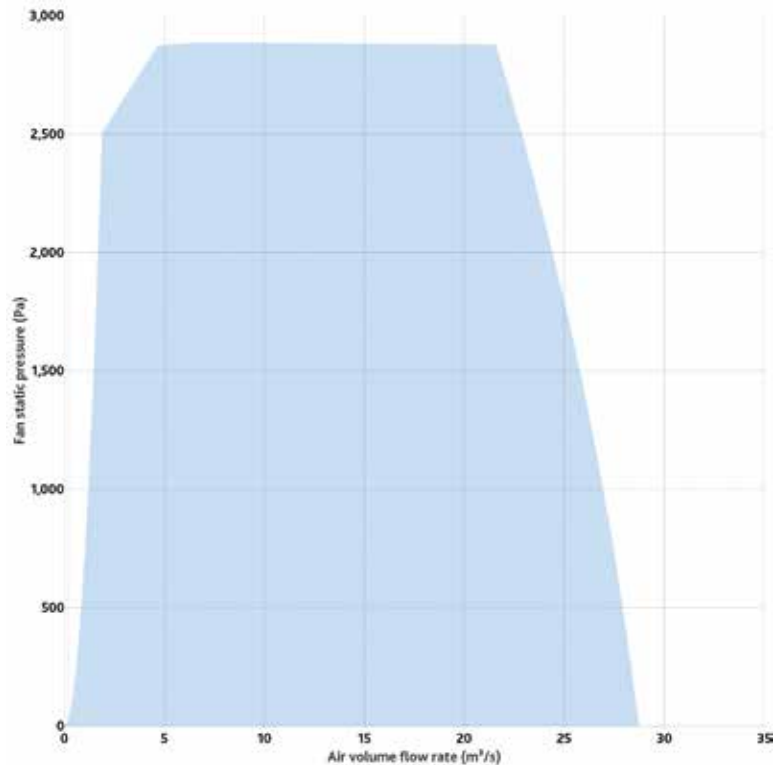

630mm Ø

5 POLE

710mm Ø

5 POLE



Details illustrated are a small representation of the complete range. Please contact Nuairé for selections specific to your project applications and/or request software download.

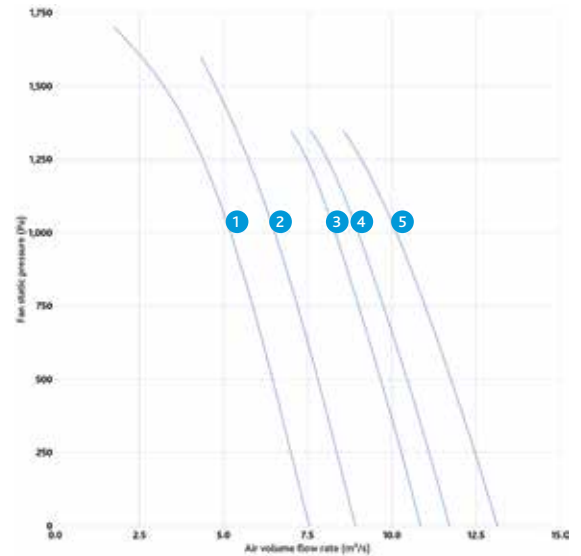
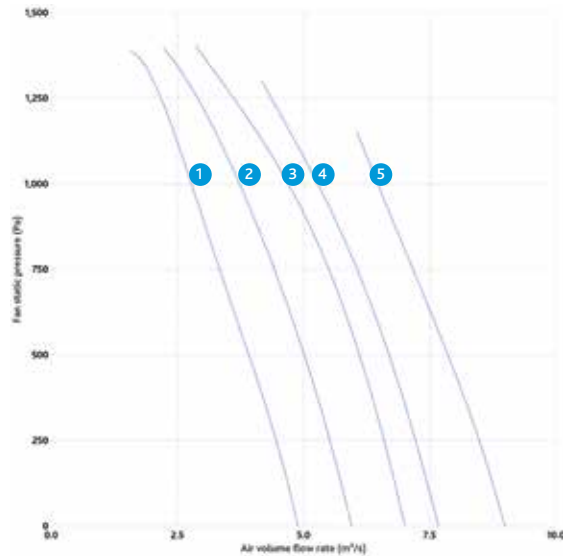

630/710mm Ø 5 POLE

	CURVE	FAN CODE 300/2	BLADE ANGLE °	MOTOR RATING (KW)	RPM SPEED	MOTOR CURRENTS		SOUND POWER LEVELS RE 1 PWATT (Hz) INDUCT INLET								dB(A) @3M
						FLC	SC (DOL)	63	125	250	500	1K	2K	4K	8K	
630	1	AX63LQ*2	10	5.5	2900	10.2	76.5	93	92	99	103	106	102	95	89	72
	2	AX63LQ*2	15	7.5	2910	13.8	103.5	98	97	101	107	107	101	95	91	74
	3	AX63LQ*2	20	9.2	2910	16.8	126	101	103	104	111	106	99	95	93	73
	4	AX63LQ*2	23	13.2	2930	23.88	149.25	103	101	105	107	102	97	93	90	73
	5	AX63LQ*2	29	15	2930	26.9	201.75	104	101	105	106	103	97	94	92	72
710	1	AX71LQ*2	10	9.2	2910	16.8	126	92	90	104	101	104	103	99	96	74
	2	AX71LQ*2	15	13.2	2930	23.88	149.25	95	91	104	102	103	101	98	94	72
	3	AX71LQ*2	22	18	2930	32.28	201.75	101	96	106	103	101	97	95	93	70
	4	AX71LQ*2	25	22.2	2940	39.12	244.5	102	96	106	104	102	97	95	94	70
	5	AX71LQ*2	30	30	2950	52.3	392.25	104	97	107	103	103	97	97	96	71



Details illustrated are a small representation of the complete range. Please contact Nuairé for selections specific to your project applications and/or request software download.

800mm Ø

4 POLE

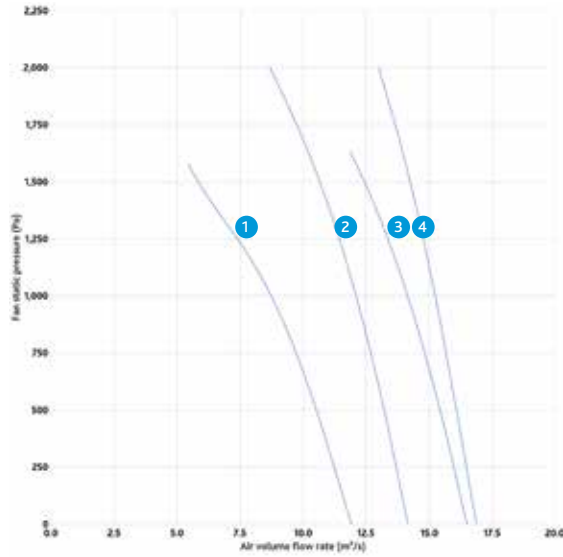

900mm Ø

4 POLE

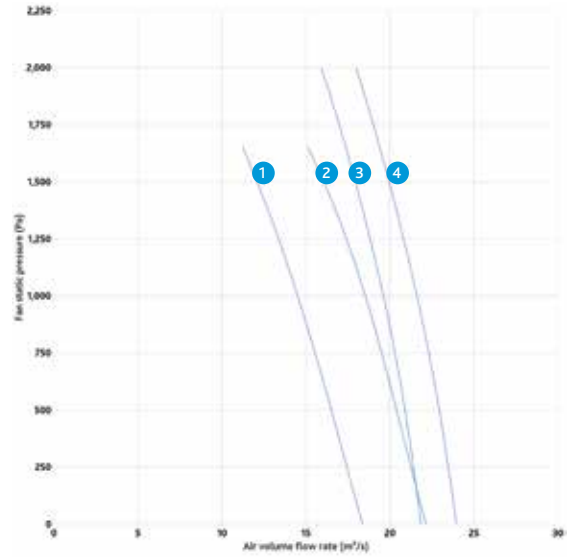

800/900mm Ø 4 POLE

						MOTOR CURRENTS		SOUND POWER LEVELS RE 1 PWATT (Hz) INDUCT INLET								
	CURVE	FAN CODE 300/2	BLADE ANGLE °	MOTOR RATING (KW)	RPM SPEED	FLC	SC (DOL)	63	125	250	500	1K	2K	4K	8K	dB(A) @3M
800	1	AX80MA*2	17	22	2950	38.6	289.5	99	96	107	105	105	102	100	98	74
	2	AX80MG*2	22	37	2950	64.1	480.75	106	99	114	108	108	104	102	99	77
	3	AX80MC*2	27	55	2930	96.8	726	106	101	103	110	111	104	103	102	77
	5	AX80MI*2	29	66	2930	116.16	726	107	101	106	113	110	105	103	102	79
900	1	AX90MA*2	16	37	2950	64.1	480.75	102	97	109	110	110	105	103	101	78
	2	AX90MA*2	22	55	2930	96.8	726	106	100	113	112	113	108	105	104	80
	3	AX90MC*2	22	75	2930	125.45	940.875	107	102	107	115	114	109	105	104	81
	5	AX90MC*2	25	90	2930	150.54	940.875	109	104	107	116	116	110	107	105	82



THE COMPLETE VENTILATION SOLUTION

- THE COMPLETE RANGE SOLUTION TAILORED TO MEET YOUR PROJECT REQUIREMENTS WORLDWIDE.
- EXPANSIVE RANGE TO MEET YOUR LOCAL REGULATIONS.
- DESIGNED AND TESTED TO THE RECOGNISED INDUSTRY STANDARD IN AMCA ACCREDITED LABORATORIES.



- AXIAL CONFIGURATOR SOFTWARE PROVIDING THE TAILORED SOLUTION AT YOUR FINGERTIPS.
- PRODUCT DEVELOPMENT AND INNOVATION.
- PEDIGREE RENOWNED WORLDWIDE.
- THE COMPLETE SUPPORT TEAM TO GUIDE AND SUPPORT YOU WITH YOUR HVAC PROJECT REQUIREMENTS.

HIGH TEMPERATURE AXIAL RANGE
300°C/2hrs & 400°C/2hrs

AXIAL RANGE - AMBIENT
VENTILATION SOLUTIONS

60Hz
VENTILATION SOLUTIONS

WORLDWIDE
VENTILATION SOLUTIONS

TO UPDATE

HIGH TEMPERATURE
VENTILATION SOLUTIONS

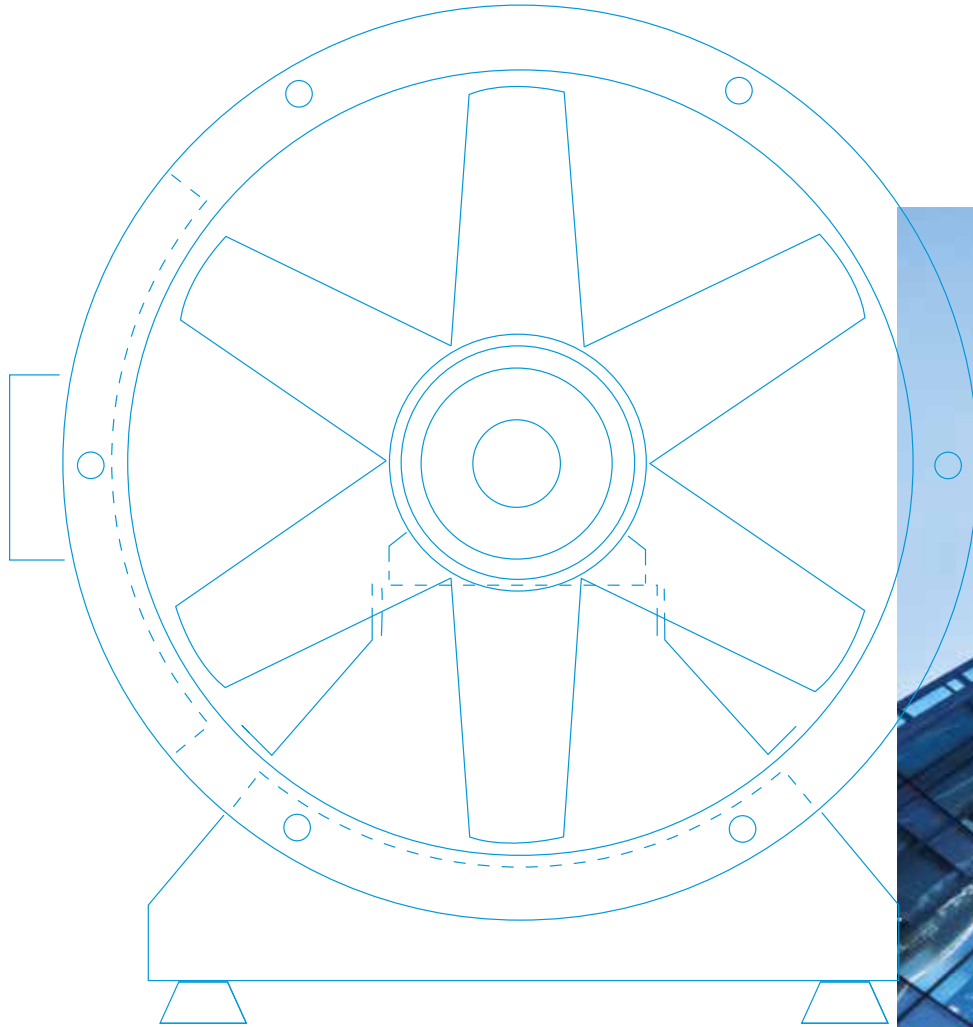

NUAIRE. FOR THE COMPLETE VENTILATION SOLUTION

T +44(0)29 2085 8484 E INTERNATIONAL@NUAIRE.CO.UK W NUAIREGROUP.COM [@NUAIREGROUP](https://twitter.com/NUAIREGROUP)

September 2018.





HIGH TEMPERATURE AXIAL RANGE

300°C/2Hrs & 400°C/2Hrs

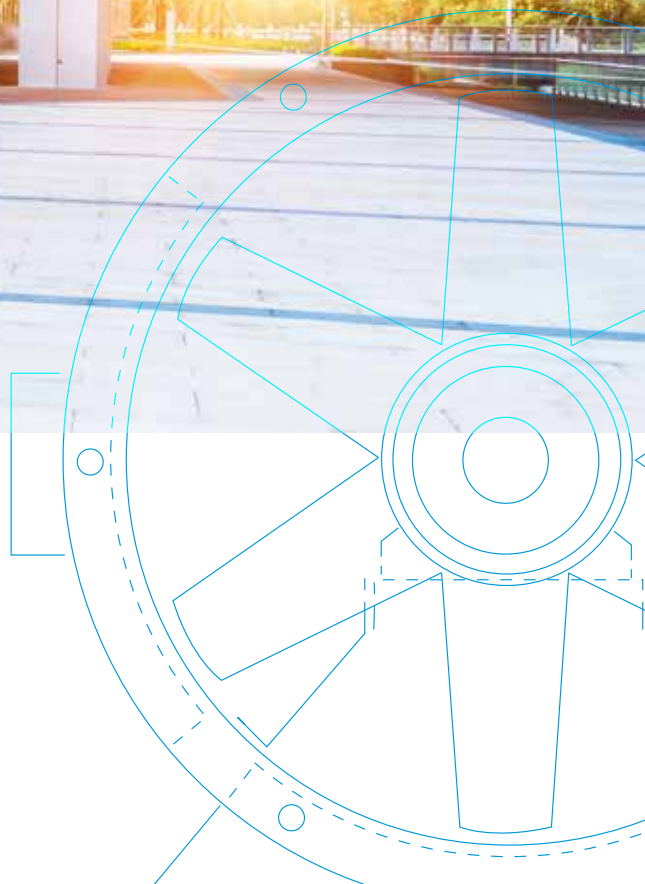

NUAIRE. FOR THE COMPLETE VENTILATION SOLUTION



WITH A RECORD OF QUALITY WHICH IS THE ENVY OF THE INDUSTRY...

...Nuaire is a British company with a long history of innovation in the field of ventilation and air movement solutions, and its products are known across the world for their superb quality and efficiency.

Founded in 1966, Nuaire has a long and much-admired heritage in developing and manufacturing ventilation products. A product range renowned worldwide, coupled with unrivalled customer service which has ensured that Nuaire's products have been distributed globally, including the Middle East, Europe, the USA and Asia.





CONTENTS

The following pages serve to provide a brief overview of the Nuaire High Temperature Axial Ranges.

For the best fan solution, selected and tailored to your project and application requirements, please contact Nuaire and/or download the Axial Configurator software, providing access to the expansive range of standard and configurable options available.



	PAGE
HIGH TEMPERATURE AXIAL RANGE 300°C/2Hrs & 400°C/2Hrs	4
315mm Ø	8
350mm Ø	9
400mm Ø	10
450mm Ø	11
500mm Ø	12
560mm Ø	13
630mm Ø	14
710mm Ø	15
800mm Ø	16
900mm Ø	17
1000mm Ø	18
1120mm Ø	19
1250mm Ø	20
1400mm Ø	21
1500mm Ø	21
1600mm Ø	22
MATCHING ANCILLARIES	23
HIGH PRESSURE	24



HIGH TEMPERATURE AXIAL RANGE 300°C/2Hrs & 400°C/2Hrs

Nuaire offers a comprehensive range of high performance axial fans, from 250mm to 2000mm diameter that will suit applications up to 120m³/s duty range, including AXUS High Temperature Axials, Smoke Contra Axials and Smoke Run and Standby Axials.



KEY BENEFITS:

- ▶ **INDEPENDENTLY TESTED** - EN 12101-3:2015
- ▶ **HIGH PERFORMANCE** - UP TO 120M³/s
- ▶ **FLEXIBLE SOLUTION** - SUITABLE FOR INTERNAL & EXTERNAL APPLICATIONS
- ▶ **WIDE RANGE** - WITH THE WIDEST RANGE OF AXIAL SOLUTIONS CONFIGURED TO MEET YOUR PROJECT REQUIREMENTS, ENSURING OPTIMUM FAN EFFICIENCIES
- ▶ **ENERGY EFFICIENT** - RANGES DEVELOPMENT FOCUSED ON MEETING GLOBAL EFFICIENCY STANDARDS
- ▶ **GALVANISED STEEL CONSTRUCTION** - ENSURES STRENGTH, DURABILITY & PROTECTION
- ▶ **AMCA APPROVED LABS** - BOTH TYPE 'A' & 'D' LABORATORIES AT NUAIRE ARE ACCREDITED TO THE AMCA STANDARD
- ▶ **TESTED TO THE HIGHEST STANDARDS** - AIR PERFORMANCE TO ISO 5801 (PART 1) 2017 WITH ACOUSTIC PERFORMANCE TO AMCA 300 & ISO 13347

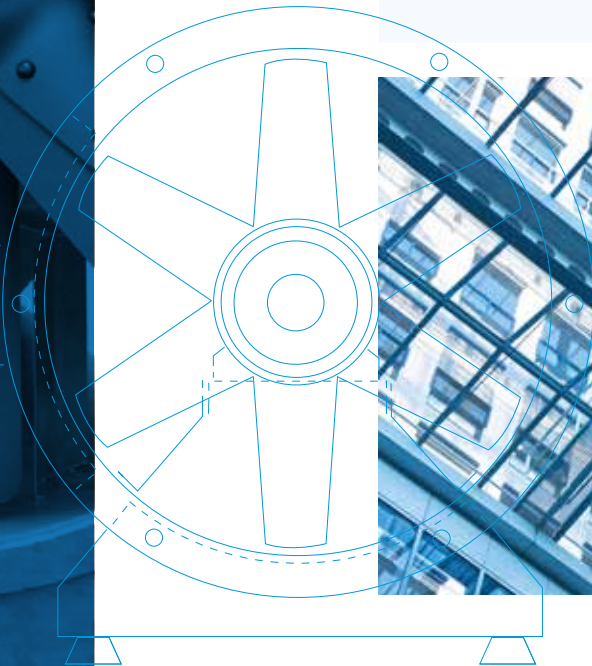



CONSULTANT SPECIFICATION



CASING

Long cased covering both the motor and impeller, manufactured from heavy gauge galvanised steel (Either Pre-gal or HDG), corrosion resistant to BS EN 10142 1991 with integrally formed inlet and outlet mounting flange, with pre-drilled bolt holes.

Cases are available in a standard execution or with integral case mounted guide vanes – unique to Nuaire – providing performance-enhancing characteristics.

Cases are complete with an externally mounted terminal box which is pre-wired from the motor with a flying lead, ensuring ease of installation at site.

Case material options available:

- Hot dip galvanized after manufacture
- Painted: Polyester powder or epoxy



PERFORMANCE

Up to 120m³/s duty range; for larger duties contact Nuaire.



CERTIFICATION AND OPERATING TEMPERATURE

Suitable for day to day environmental extract up to a maximum of 60°C and one-off emergency extract for either 300°C or 400°C for 2 hours depending on local fire code. Suitable for smoke reservoir and non-smoke reservoir applications.



MOTOR

Motors incorporated are fully cast TEAO (Totally Enclosed, Non Ventilated Air Over) with Class F Temperature rise and Class H insulation, IP55 protection, suitable to operate for day to day environmental extract (up to 60°C) and a one off emergency extract, either 300°C or 400°C for two hours (S2), depending on the project requirements.

Motors are available in a range of efficiency Classifications: IE1, IE2, IE3 all tested & certified as a component of the complete fan assembly to EN 12101-3.

Motors are pre-wired to an external case-mounted terminal box as standard, ensuring ease of installation, protected to dust and water ingress to IP55.

Motors are available with additional features in accordance with EN12101-3 such as:

- PTC Thermal overload protection
- Anti-condensation heaters
- IP upgrades optional



ANCILLARIES

- Matching flanges
- Flexible connections
- Anti-vibration mounts
- Mounting brackets
- Acoustic jackets
- Attenuators
- Guards
- Inlet cones
- Backdraught dampers
- Controls (day-to-day use only)
- Bellmouth



IMPELLER

For 300°C for 2hrs applications impellers are high efficiency aerofoil profile, ensuring optimum efficiency, expansive performance envelopes and low noise characteristics. Impellers can be either fully cast aluminium construction or sheet steel depending on the project specifications. Fully reversible option available.

For 400°C for 2hrs applications impellers are high efficiency profile, fabricated completely from mild steel ensuring optimum performance and safety under emergency conditions. Fully reversible option available.



INSTALLATION

Suitable for internal and external operation and installed at any angle. DW/144 and general good practice standards for installation should be taken into consideration at design stage.



APPLICATIONS

- Car parks & smoke
- Industrial
- Boiler rooms
- Lift motor rooms
- Sports halls
- Factories & warehouses
- Hospitals, surgeries & medical centres
- Offices & commercial
- Supermarkets
- Retail, leisure & sports facilities
- Public buildings
- Tunnel & metros

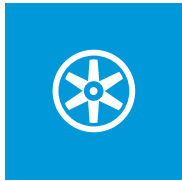

HIGH TEMPERATURE AXIAL RANGE F300°C/2Hrs & F400°C/2Hrs

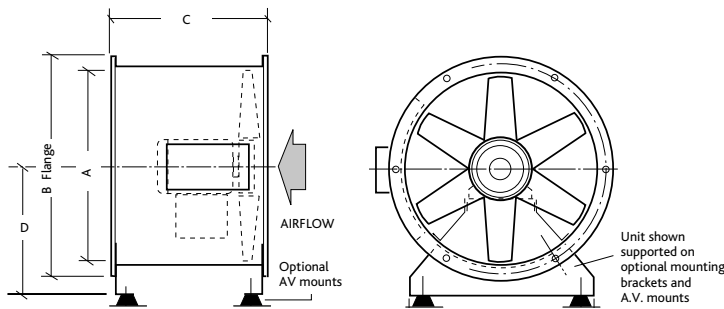

CODING AX100X-XX

AX	100	X	-	X	X
1	2	3	4	5	

SAMPLE CODING

1. Axial fan
2. Size of casing in cm
3. Impeller specification reference
4. Motor speed in poles
5. Operating temperature reference

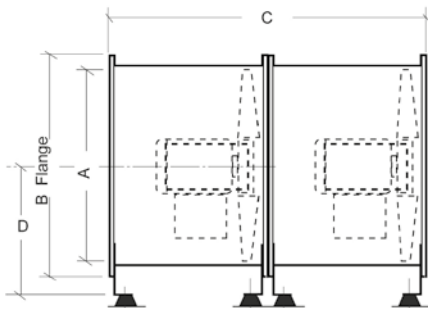

300°C/2

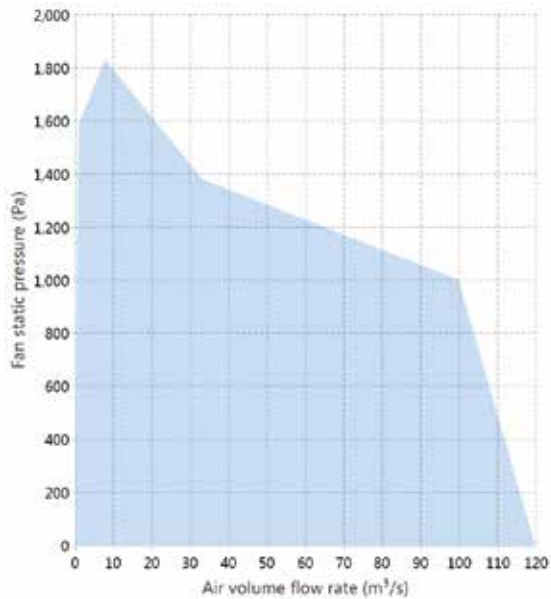

400°C/2

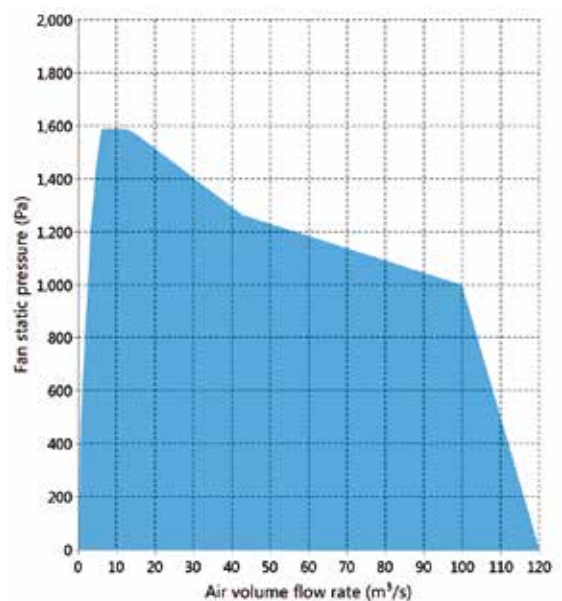

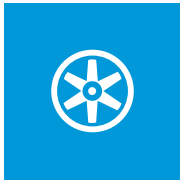

RANGE TYPES

SMOKE SINGLE STAGE
AXIAL (AX)



DIMENSIONS (mm)

MODEL	A	B	C	D
AX31	315	400	365	210
AX35	350	430	380	240
AX40	400	490	440	270
AX45	450	540	450	300
AX45	450	540	600	300
AX50	500	608	465	340
AX50	500	608	615	340
AX56	560	670	440	370
AX56	560	670	615	370
AX63	630	740	480	430
AX63	630	740	600	430
AX63	630	740	800	430
AX71	710	814	455	470
AX71	710	814	700	470
AX80	800	910	440	540
AX80	800	910	840	540
AX90	900	1016	740	600
AX100	1000	1128	740	670
AX100	1000	1128	850	670
AX112	1120	1240	730	750
AX112	1120	1240	865	750
AX112	1120	1240	1010	750
AX125	1250	1365	865	830
AX125	1250	1365	1010	830

SMOKE CONTRA ROTATING
AXIAL (AXC)



DIMENSIONS (mm)

MODEL	A	B	C	D
AXC31	315	400	730	210
AXC35	350	430	760	240
AXC40	400	490	880	270
AXC45	450	540	900	300
AXC50	500	608	930	340
AXC50	500	608	1230	340
AXC56	560	670	880	370
AXC56	560	670	1230	370
AXC63	630	740	960	430
AXC63	630	740	1200	430
AXC71	710	814	910	470
AXC71	710	814	1400	470
AXC80	800	910	880	540
AXC80	800	910	1680	540
AXC90	900	1016	1480	600
AXC100	1000	1128	1480	670
AXC100	1000	1128	1700	670
AXC112	1120	1240	1460	750
AXC112	1120	1240	1730	750
AXC112	1120	1240	2020	750
AXC125	1250	1365	1730	830
AXC125	1250	1365	2020	830

SMOKE RUN AND STANDBY
AXIAL (AXT)



DIMENSIONS (mm)

MODEL	A	B	C	D
AXT31	315	400	730	210
AXT35	350	430	760	240
AXT40	400	490	880	270
AXT45	450	540	900	300
AXT50	500	608	930	340
AXT50	500	608	1230	340
AXT56	560	670	880	370
AXT56	560	670	1230	370
AXT63	630	740	960	430
AXT63	630	740	1200	430
AXT71	710	814	910	470
AXT71	710	814	1400	470
AXT80	800	910	880	540
AXT80	800	910	1680	540
AXT90	900	1016	1480	600
AXT100	1000	1128	1480	670
AXT100	1000	1128	1700	670
AXT112	1120	1240	1460	750
AXT112	1120	1240	1730	750
AXT112	1120	1240	2020	750
AXT125	1250	1365	1730	830
AXT125	1250	1365	2020	830

For larger diameters, please contact Nuairé for details.

315mm Ø

2 POLE

4 POLE



Details illustrated are a small representation of the complete range. Please contact Nuair for selections specific to your project applications and/or request software download.

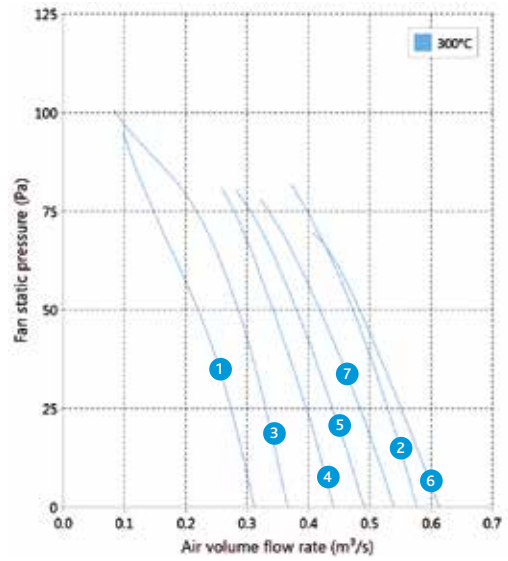
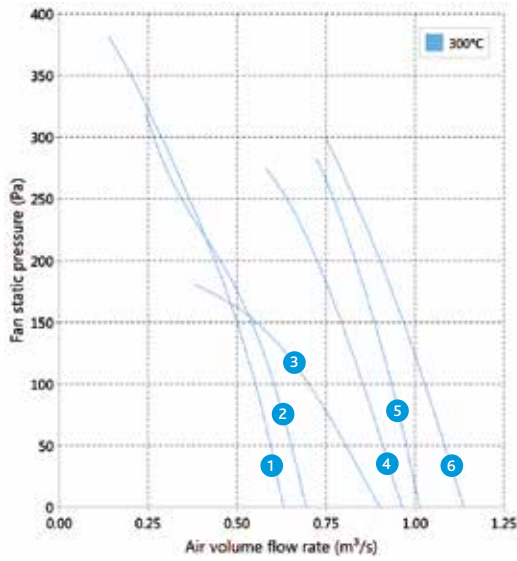

315mm Ø 2 POLE

	MOTOR CURRENTS							SOUND POWER LEVELS RE 1 PWATT (Hz) INDUCT INLET								
	CURVE	FAN CODE	BLADE ANGLE °	MOTOR RATING (kW)	RPM SPEED	FLC	SC (DOL)	63	125	250	500	1K	2K	4K	8K	dB(A) @3M
								63	125	250	500	1K	2K	4K	8K	
300	1	AX31M-27	20	0.9	2695	2.10	9.14	86	81	97	80	78	74	70	63	53
	2	AX31X-27	25	0.9	2695	2.10	9.14	98	98	85	78	77	75	71	68	48
	3	AX31A-27	30	0.9	2695	2.10	9.14	84	96	84	78	76	72	66	61	46
	4	AX31X-27	35	0.9	2695	2.10	9.14	87	84	91	81	79	75	71	64	49
	5	AX31F-27	35	0.9	2695	2.10	9.14	89	79	77	78	77	74	71	65	45
	6	AX31D-27	40	0.9	2695	2.10	9.14	86	80	79	80	79	74	69	65	45

315mm Ø 4 POLE

	MOTOR CURRENTS							SOUND POWER LEVELS RE 1 PWATT (Hz) INDUCT INLET								
	CURVE	FAN CODE	BLADE ANGLE °	MOTOR RATING (kW)	RPM SPEED	FLC	SC (DOL)	63	125	250	500	1K	2K	4K	8K	dB(A) @3M
								63	125	250	500	1K	2K	4K	8K	
300	1	AX31M-47	20	0.66	1440	1.56	6.75	76	85	72	65	61	58	50	42	33
	2	AX31X-47	30	0.66	1440	1.56	6.75	79	79	72	64	61	58	49	43	32
	3	AX31X-47	35	0.66	1440	1.56	6.75	72	77	70	63	61	57	48	41	31
	4	AX31X-47	40	0.66	1440	1.56	6.75	71	82	71	64	62	58	50	44	32
	5	AX31F-47	45	0.66	1440	1.56	6.75	69	71	72	63	64	60	54	48	33
	6	AX31X-47	25	0.66	1440	1.56	6.75	79	77	72	63	61	58	48	42	32
	7	AX31F-47	40	0.66	1440	1.56	6.75	69	70	74	63	64	60	52	46	35

350mm Ø

2 POLE

4 POLE



Details illustrated are a small representation of the complete range. Please contact Nuair for selections specific to your project applications and/or request software download.

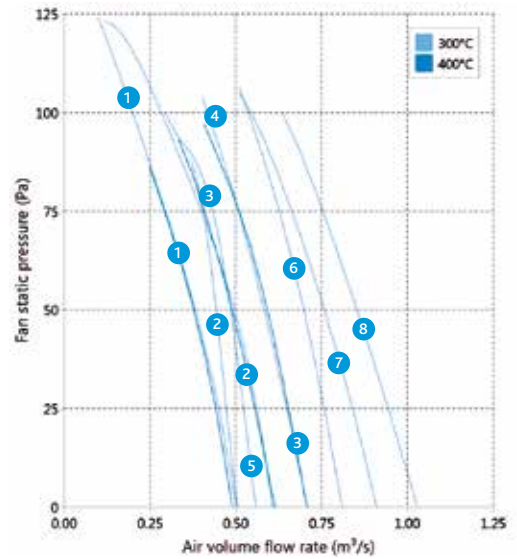
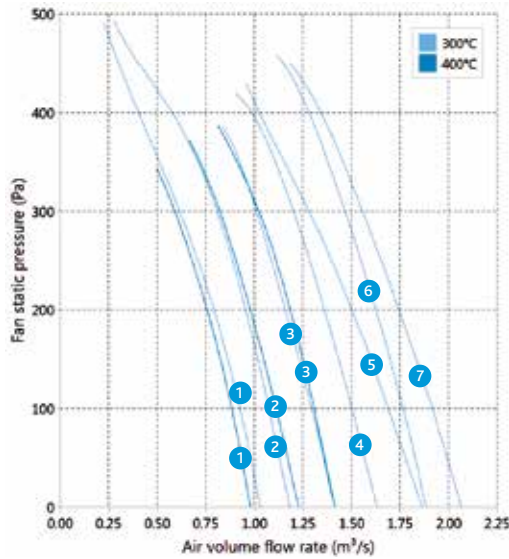

350mm Ø 2 POLE

	CURVE	FAN CODE	BLADE ANGLE °	MOTOR RATING (KW)	RPM SPEED	FLC	SC (DOL)	MOTOR CURRENTS								SOUND POWER LEVELS RE 1 PWATT (Hz) INDUCT INLET				dB(A) @3M
								63	125	250	500	1K	2K	4K	8K	63	125	250	500	
300	1	AX35M-27	20	0.9	2790	2.1	9.14	88	81	88	79	81	76	72	67	50				
	2	AX35X-27	25	0.9	2790	2.1	9.14	86	84	89	81	80	76	74	66	50				
	3	AX35X-27	30	0.9	2790	2.1	9.14	85	85	96	81	80	76	73	65	54				
	4	AX35X-27	35	1.32	2810	2.95	14.7	87	87	88	82	83	79	74	68	51				
	5	AX35M-27	40	1.32	2810	2.95	14.7	87	86	102	82	82	79	74	69	60				
	6	AX35F-27	40	1.8	2745	3.65	23.5	89	85	82	85	84	81	75	69	52				
	7	AX35F-27	45	1.8	2745	3.97	20.9	89	88	85	86	85	81	76	71	53				
400	1	AX35AW-28	15	0.9	2790	2.1	9.14	77	78	77	76	75	72	69	64	43				
	2	AX35AW-28	20	0.9	2790	2.1	9.14	80	81	80	79	78	75	72	67	45				
	3	AX35AW-28	25	0.9	2790	2.1	9.14	82	83	82	81	80	77	74	69	48				

350mm Ø 4 POLE

	CURVE	FAN CODE	BLADE ANGLE °	MOTOR RATING (KW)	RPM SPEED	FLC	SC (DOL)	MOTOR CURRENTS								SOUND POWER LEVELS RE 1 PWATT (Hz) INDUCT INLET				dB(A) @3M
								63	125	250	500	1K	2K	4K	8K	63	125	250	500	
300	1	AX35M-47	20	0.66	1440	1.44	8.12	74	81	69	66	64	61	56	50	33				
	2	AX35I-47	25	0.66	1440	1.56	6.75	70	70	73	71	67	63	58	49	36				
	3	AX35X-47	30	0.66	1440	1.44	8.12	77	93	77	67	63	59	50	43	39				
	4	AX35F-47	25	0.66	1440	1.56	6.75	82	74	71	65	64	62	56	49	34				
	5	AX35D-47	25	0.66	1440	1.49	7.37	70	69	67	66	62	61	55	48	36				
	6	AX35F-47	35	0.66	1440	1.44	8.12	72	69	78	64	64	63	56	49	39				
	7	AX35F-47	40	0.66	1440	1.44	8.12	75	71	76	64	64	61	56	50	37				
	8	AX35F-47	45	0.66	1440	1.49	7.37	76	73	78	65	65	61	57	53	39				
400	1	AX35AX-48	15	0.66	1440	1.56	6.75	62	63	61	60	59	56	52	48	26				
	2	AX35AW-28	20	0.66	1440	1.56	6.75	65	66	64	63	62	59	55	51	29				
	3	AX35AW-28	25	0.66	1440	1.56	6.75	67	68	66	65	64	61	57	53	31				

400mm Ø

2 POLE

4 POLE



Details illustrated are a small representation of the complete range. Please contact Nuair for selections specific to your project applications and/or request software download.

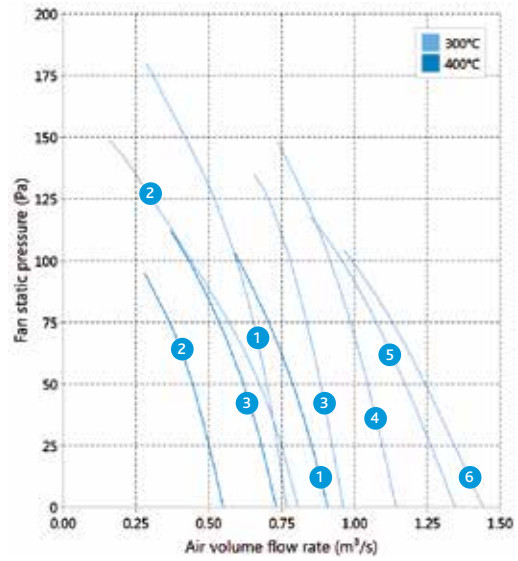
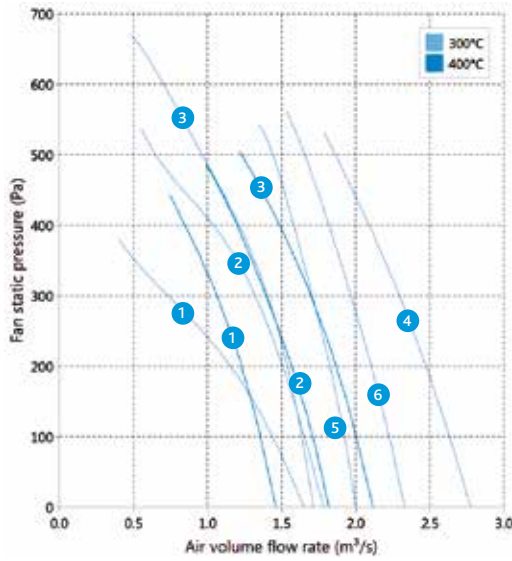

400mm Ø 2 POLE

	CURVE	FAN CODE	BLADE ANGLE °	MOTOR RATING (KW)	RPM SPEED	FLC	SC (DOL)	MOTOR CURRENTS		SOUND POWER LEVELS RE 1 PWATT (Hz) INDUCT INLET								dB(A) @3M
								63	125	250	500	1K	2K	4K	8K			
300	1	AX40C-27	25	0.9	2780	1.94	12.2	97	85	91	84	81	76	71	69	51		
	2	AX40M-27	25	1.32	2810	2.95	14.7	98	81	92	83	84	80	76	72	53		
	3	AX40F-27	25	1.32	2810	2.95	14.7	87	79	83	86	83	81	77	73	51		
	4	AX40I-27	35	2.64	2840	5.39	31.2	95	84	82	90	84	80	75	71	52		
	5	AX40I-27	45	3.6	2820	7.24	40.6	91	91	87	90	89	85	80	76	56		
	6	AX40I-27	30	1.8	2865	3.76	18.5	96	82	81	89	84	80	77	73	52		
400	1	AX40AW-28	15	0.9	2790	1.94	12.2	82	83	82	81	80	78	75	71	48		
	2	AX40AW-28	20	1.32	2810	2.95	14.7	85	86	85	84	83	81	78	74	51		
	3	AX40AW-28	25	1.32	2810	2.71	14.7	88	89	88	87	86	84	81	77	54		

400mm Ø 4 POLE

	CURVE	FAN CODE	BLADE ANGLE °	MOTOR RATING (KW)	RPM SPEED	FLC	SC (DOL)	MOTOR CURRENTS		SOUND POWER LEVELS RE 1 PWATT (Hz) INDUCT INLET								dB(A) @3M
								63	125	250	500	1K	2K	4K	8K			
300	1	AX40D-47	25	0.66	1440	1.56	6.75	75	72	81	69	66	64	58	51	42		
	2	AX40I-47	25	0.66	1440	1.56	6.75	76	72	77	73	69	67	62	53	39		
	3	AX40I-47	30	0.66	1440	1.49	7.37	76	71	76	70	67	66	61	54	38		
	4	AX40I-47	35	0.66	1440	1.49	7.37	76	71	78	70	67	65	59	53	38		
	5	AX40F-47	40	0.66	1440	1.49	7.37	79	72	83	69	66	63	58	54	40		
	6	AX40F-47	45	0.66	1440	1.49	7.37	81	74	83	69	68	64	59	55	40		
400	1	AX40AW-48	15	0.66	1440	1.56	6.75	69	70	69	68	67	65	62	58	35		
	2	AX40AW-48	20	0.66	1440	1.56	6.75	73	74	73	72	71	69	66	62	39		
	3	AX40AW-48	10	0.66	1440	1.56	6.75	67	68	67	66	65	63	60	56	33		

450mm Ø

2 POLE

4 POLE



Details illustrated are a small representation of the complete range. Please contact Nuaire for selections specific to your project applications and/or request software download.

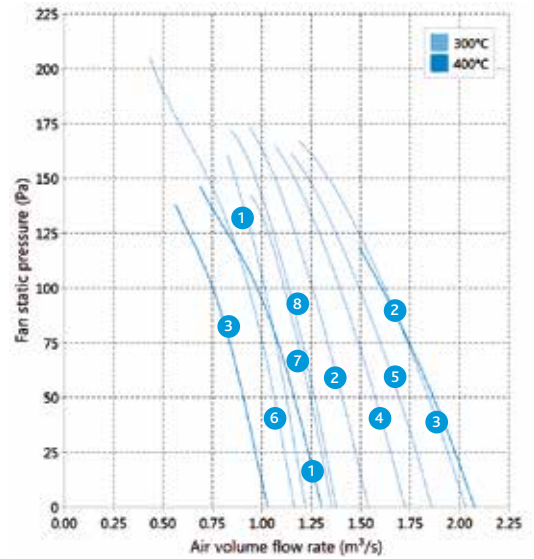
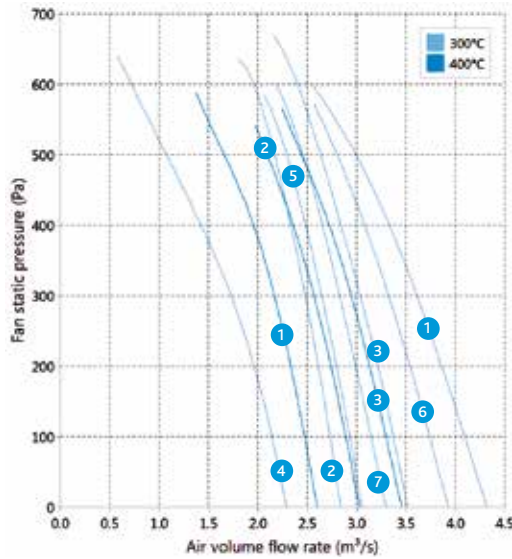

450mm Ø 2 POLE

					MOTOR CURRENTS		SOUND POWER LEVELS RE 1 PWATT (Hz) INDUCT INLET								dB(A) @3M	
CURVE	FAN CODE	BLADE ANGLE °	MOTOR RATING (KW)	RPM SPEED	FLC	SC (DOL)	63	125	250	500	1K	2K	4K	8K		
300	1	AX45AA-27	37.5	4.8	2890	9.3	53.1	91	91	88	91	90	84	81	75	57
	2	AX45AA-27	30	3.6	2880	6.87	49	92	90	91	92	91	86	82	78	57
	3	AX45F-27	40	4.8	2890	9.16	50.2	89	88	83	91	89	85	81	78	55
	4	AX45F-27	45	4.8	2870	9.74	51	86	88	84	91	89	85	82	79	57
	5	AX45P-27	32.5	3.6	2870	7.24	40.6	86	88	86	90	89	85	81	77	56
	6	AX45P-27	35	4.8	2885	9.3	53.1	88	89	87	90	89	83	79	75	56
	7	AX45D-27	25	1.8	2865	3.73	18.5	82	81	79	87	87	83	80	78	54
400	1	AX45AW-28	20	1.8	2865	3.97	20.9	89	89	89	90	89	87	85	81	57
	2	AX45AW-28	25	2.64	2840	5.39	31.2	92	92	92	93	92	90	88	84	60
	3	AX45AW-25	30	2.64	2840	5.39	31.2	94	94	94	95	94	92	90	86	62

450mm Ø 4 POLE

					MOTOR CURRENTS		SOUND POWER LEVELS RE 1 PWATT (Hz) INDUCT INLET								dB(A) @3M	
CURVE	FAN CODE	BLADE ANGLE °	MOTOR RATING (KW)	RPM SPEED	FLC	SC (DOL)	63	125	250	500	1K	2K	4K	8K		
300	1	AX45AA-47	37.5	0.66	1440	1.56	6.75	79	81	80	74	71	66	59	54	41
	2	AX45P-27	25	0.66	1440	1.56	6.75	73	79	79	76	74	70	65	57	43
	3	AX45P-47	40	0.66	1440	1.49	7.37	77	80	80	74	71	66	60	55	42
	4	AX45P-47	45	0.66	1440	1.56	6.75	79	80	80	73	71	66	60	55	42
	5	AX45S-47	35	0.66	1440	1.56	6.75	79	83	82	79	77	71	67	60	45
	6	AX45S-47	40	0.66	1440	1.56	6.75	79	85	85	80	78	71	65	59	46
	7	AX45S-47	45	0.66	1440	1.56	6.75	79	83	84	82	78	71	66	59	46
	8	AX45AA-47	30	0.66	1440	1.56	6.75	77	80	79	74	72	68	61	55	41
400	1	AX45AW-48	40	0.66	1440	1.56	6.75	78	78	77	78	77	75	73	68	45
	2	AX45AW-48	15	0.66	1440	1.56	6.75	77	77	76	77	76	74	72	67	44
	3	AX48AW-48	20	0.66	1440	1.56	6.75	79	79	78	79	78	76	74	69	46

500mm Ø

2 POLE

4 POLE



Details illustrated are a small representation of the complete range. Please contact Nuair for selections specific to your project applications and/or request software download.

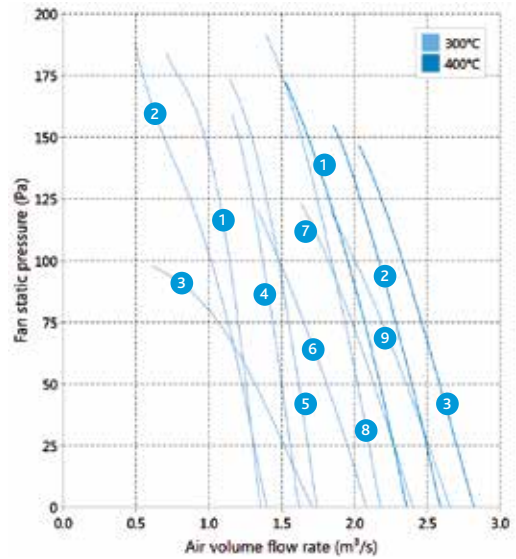
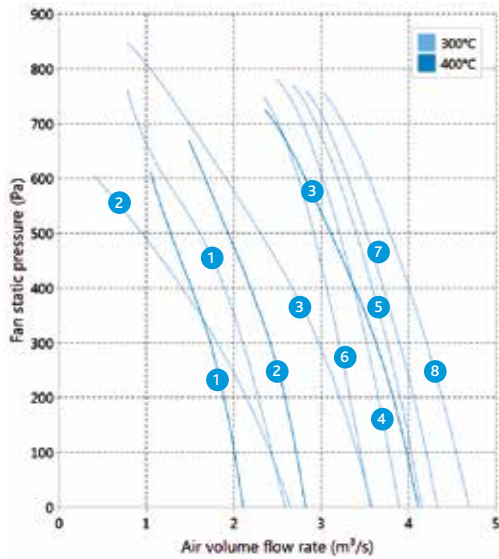

500mm Ø 2 POLE

	CURVE	FAN CODE	BLADE ANGLE °	MOTOR RATING (KW)	RPM SPEED	FLC	SC (DOL)	MOTOR CURRENTS								SOUND POWER LEVELS RE 1 PWATT (Hz) INDUCT INLET				dB(A) @3M
								63	125	250	500	1K	2K	4K	8K	63	125	250	500	
300	1	AX50B-27	25	1.32	2810	2.95	14.7	94	80	89	90	89	89	84	83	59				
	2	AX50Q-27	20	2.64	2760	5.39	31.2	88	88	92	94	93	90	84	80	60				
	3	AX50D-27	30	2.64	2760	5.39	31.2	94	86	87	96	95	92	85	81	61				
	4	AX50S-27	32.5	8.63	2875	16.6	92.2	95	91	92	96	94	90	86	83	61				
	5	AX50S-27	35	8.63	2925	16.6	92.2	95	93	93	98	95	90	86	83	62				
	6	AX50S-27	37.5	9	2875	17	95.8	101	96	95	98	95	90	86	84	62				
	7	AX50S-27	40	8.63	2875	16.6	92.2	100	95	93	97	96	91	87	85	62				
	8	AX50S-27	45	13.2	2925	24.7	87.8	99	96	95	99	96	92	87	85	64				
400	1	AX50AW-28	10	2.64	2840	5.39	31.2	92	92	91	92	91	89	88	84	60				
	2	AX50AW-28	15	2.64	2840	5.39	31.2	92	92	91	92	91	89	88	84	60				
	3	AX50AW-28	25	4.8	2840	9.16	50.2	97	97	96	97	96	94	93	89	65				

500mm Ø 4 POLE

	CURVE	FAN CODE	BLADE ANGLE °	MOTOR RATING (KW)	RPM SPEED	FLC	SC (DOL)	MOTOR CURRENTS								SOUND POWER LEVELS RE 1 PWATT (Hz) INDUCT INLET				dB(A) @3M
								63	125	250	500	1K	2K	4K	8K	63	125	250	500	
300	1	AX50O-47	20	0.66	1440	1.56	6.75	76	77	77	78	75	72	66	58	42				
	2	AX50S-47	25	0.66	1440	1.56	6.75	80	81	84	80	77	73	68	61	46				
	3	AX50C-47	30	0.66	1440	1.56	6.75	85	88	80	78	71	67	61	53	42				
	4	AX50S-47	30	0.66	1390	1.44	8.12	83	80	83	78	76	72	66	60	45				
	5	AX50S-47	32.5	0.66	1390	1.56	6.75	81	82	87	79	77	72	67	60	47				
	6	AX50N-47	35	0.66	1440	1.56	6.75	89	86	79	77	73	70	66	61	42				
	7	AX50D-47	40	0.66	1440	1.49	7.37	77	77	84	82	78	73	65	60	44				
	8	AX50S-47	40	0.66	1390	1.56	6.75	85	83	83	79	77	71	66	61	45				
	9	AX50D-47	45	0.66	1440	1.49	7.37	78	78	85	83	79	74	66	61	45				
400	1	AX50AW-48	30	0.66	1440	1.56	6.75	81	81	80	81	80	78	77	73	49				
	2	AX50AW-48	35	0.66	1440	1.56	6.75	81	81	80	81	80	78	77	73	49				
	3	AX50AW-48	40	0.9	1435	2.05	8.71	81	81	80	81	80	78	77	73	49				

560mm Ø

2 POLE

4 POLE



Details illustrated are a small representation of the complete range. Please contact Nuair for selections specific to your project applications and/or request software download.

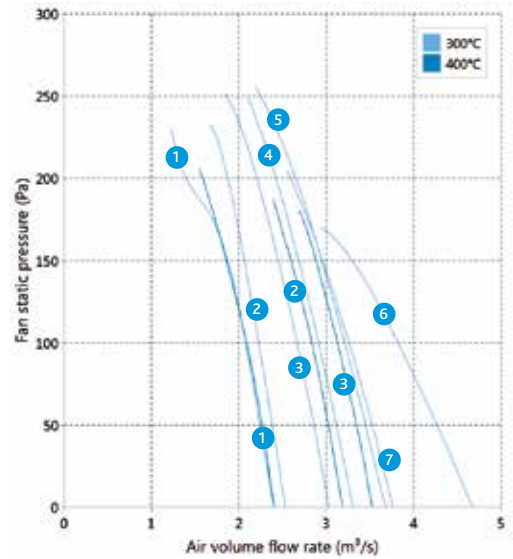
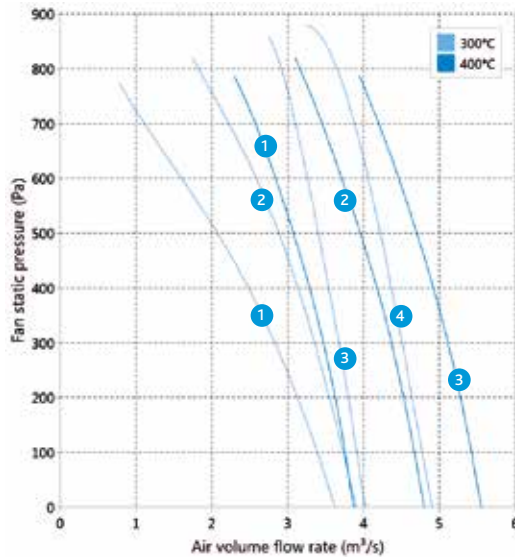

560mm Ø 2 POLE

	CURVE	FAN CODE	BLADE ANGLE °	MOTOR RATING (KW)	RPM SPEED	FLC	SC (DOL)	MOTOR CURRENTS								SOUND POWER LEVELS RE 1 PWATT (Hz) INDUCT INLET				dB(A) @3M
								63	125	250	500	1K	2K	4K	8K	63	125	250	500	
300	1	AX56D-27	25	2.64	2480	5.39	31.2	89	83	82	88	91	88	86	84	59				
	2	AX56F-27	25	3.6	2880	6.87	49	82	87	84	91	93	91	87	85	61				
	3	AX56S-27	25	8.63	2925	16.6	92.2	88	91	90	98	96	93	89	87	63				
	4	AX56N-27	30	4.8	2890	9.16	50.2	91	101	94	93	92	88	88	85	63				
400	1	AX56AX-28	15	4.8	2840	9.3	53.1	97	97	98	97	95	94	92	89	65				
	2	AX56AX-28	20	6.33	2845	12	79	100	100	101	100	98	97	95	92	68				
	3	AX56AX-28	25	9	2875	17.3	92	102	102	103	102	100	99	97	94	70				

560mm Ø 4 POLE

	CURVE	FAN CODE	BLADE ANGLE °	MOTOR RATING (KW)	RPM SPEED	FLC	SC (DOL)	MOTOR CURRENTS								SOUND POWER LEVELS RE 1 PWATT (Hz) INDUCT INLET				dB(A) @3M
								63	125	250	500	1K	2K	4K	8K	63	125	250	500	
300	1	AX56P-47	25	0.66	1440	1.56	6.75	80	82	83	83	80	77	72	64	49				
	2	AX56S-47	30	1.32	1430	2.84	15.6	74	78	76	82	81	77	74	72	48				
	3	AX56S-47	35	1.32	1430	3.14	14.9	75	78	76	83	80	76	73	69	48				
	4	AX56S-47	40	2.64	1420	5.39	33.7	83	85	84	83	79	75	72	67	46				
	5	AX56S-47	45	2.64	1420	5.67	27.1	82	83	87	82	80	76	73	68	48				
	6	AX56X-47	50	1.8	1420	3.69	23.5	91	86	78	80	77	71	66	63	43				
	7	AX56AA-47	45	2.64	1420	5.39	33.7	82	82	83	83	79	76	73	67	50				
400	1	AX56AX-48	20	0.66	1390	1.56	6.75	80	80	81	80	78	77	75	72	48				
	2	AX56AX-48	30	1.32	1430	3.14	14.9	83	83	84	83	81	80	78	75	51				
	3	AX56AX-48	35	1.32	1390	3.14	14.9	84	84	85	84	82	81	79	76	52				

630mm Ø

2 POLE

4 POLE



Details illustrated are a small representation of the complete range. Please contact Nuair for selections specific to your project applications and/or request software download.

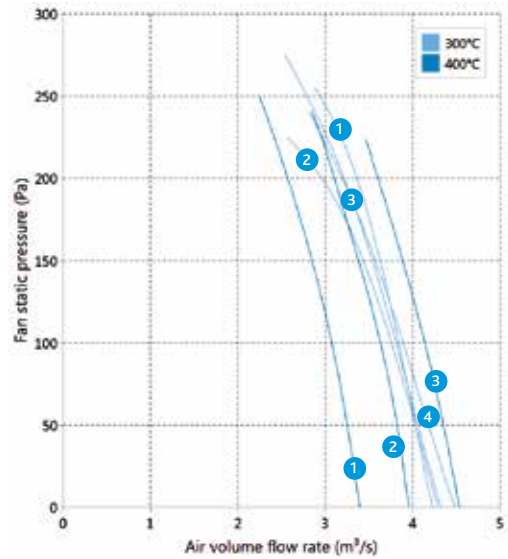
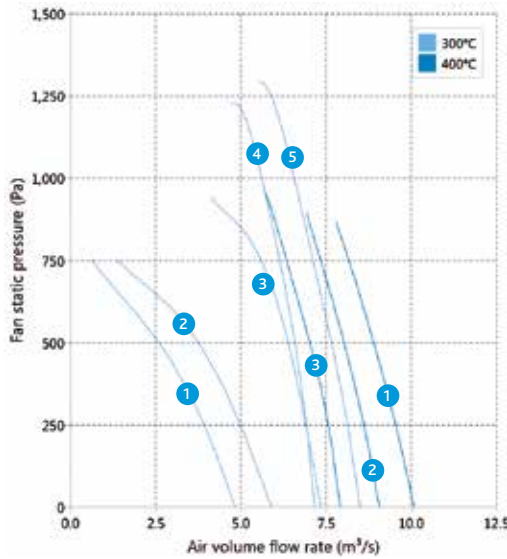

630mm Ø 2 POLE

	CURVE	FAN CODE	BLADE ANGLE °	MOTOR RATING (KW)	RPM SPEED	FLC	SC (DOL)	MOTOR CURRENTS								SOUND POWER LEVELS RE 1 PWATT (Hz) INDUCT INLET				dB(A) @3M
								63	125	250	500	1K	2K	4K	8K	63	125	250	500	
300	1	AX63N-27	20	3.6	2835	7.24	40.6	87	88	95	92	93	90	87	84	61				
	2	AX63N-27	25	4.8	2840	9.3	53.1	94	101	92	97	93	88	85	85	60				
	3	AX63AD-27	30	18	2945	32.9	230	93	95	94	104	98	95	91	90	66				
	4	AX63P-27	30	13.2	2930	24.1	160	91	97	95	100	97	93	90	89	64				
	5	AX63AD-27	35	26.4	2935	47.4	286	95	97	98	107	100	95	92	89	68				
400	1	AX63AY-28	35	25.3	2925	46.3	313	104	105	107	105	105	103	101	97	73				
	2	AX63AY-28	30	25.3	2925	46.3	313	102	103	105	103	103	101	99	95	71				
	3	AX63AY-28	25	25.3	2925	46.3	313	100	101	103	101	101	99	97	93	69				

630mm Ø 4 POLE

	CURVE	FAN CODE	BLADE ANGLE °	MOTOR RATING (KW)	RPM SPEED	FLC	SC (DOL)	MOTOR CURRENTS								SOUND POWER LEVELS RE 1 PWATT (Hz) INDUCT INLET				dB(A) @3M
								63	125	250	500	1K	2K	4K	8K	63	125	250	500	
300	1	AX63F-47	40	1.32	1400	3.14	14.9	77	75	83	81	80	77	73	68	49				
	2	AX63P-47	32.5	2.64	1385	5.67	27.1	80	83	89	88	82	80	77	69	52				
	3	AX63Z-47	35	1.32	1400	3.14	14.9	89	85	89	86	80	77	71	64	51				
	4	AX63M-47	37.5	1.32	1400	3.14	14.9	81	101	83	85	80	76	71	66	50				
400	1	AX63AY-48	20	1.32	1400	3.14	14.9	82	83	85	83	83	81	79	75	51				
	2	AX63AY-48	25	1.8	1410	3.95	18.7	85	86	88	86	86	84	82	78	54				
	3	AX63AY-48	30	1.8	1410	3.95	18.7	86	87	89	87	87	85	83	79	55				



For High Pressure range refer to page 28.

710mm Ø

4 POLE

6 POLE



Details illustrated are a small representation of the complete range. Please contact Nuair for selections specific to your project applications and/or request software download.

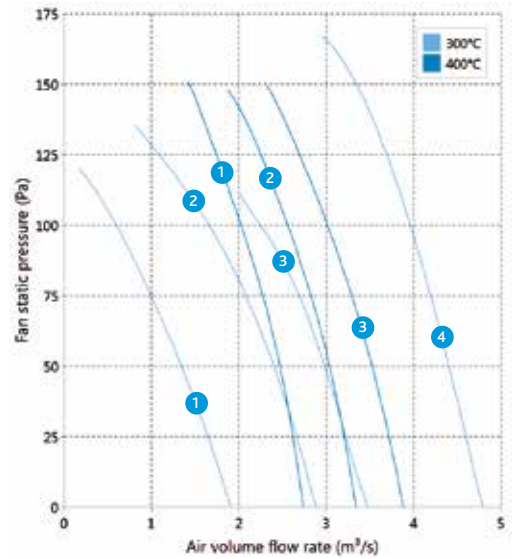
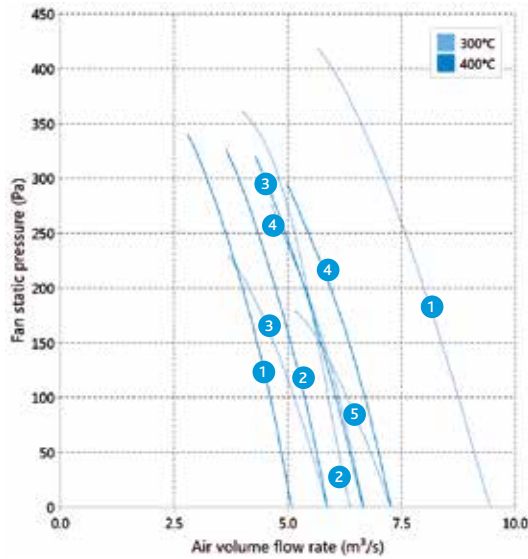

710mm Ø 4 POLE

	CURVE	FAN CODE	BLADE ANGLE °	MOTOR RATING (KW)	RPM SPEED	FLC	SC (DOL)	MOTOR CURRENTS								SOUND POWER LEVELS RE 1 PWATT (Hz) INDUCT INLET				dB(A) @3M
								63	125	250	500	1K	2K	4K	8K	63	125	250	500	
300	1	AX71AA-47	40	4.8	1440	9.73	56.2	84	84	94	90	86	83	80	72	52				
	2	AX71O-47	45	3.6	1410	7.59	39.1	94	92	88	88	85	84	78	74	50				
	3	AX71P-47	37.5	4.8	1430	9.73	56.2	87	88	93	88	84	82	80	73	51				
	4	AX71AD-47	50	9	1465	16.6	118	88	86	93	90	87	84	80	76	53				
	5	AX710-47	32.5	2.64	1420	5.49	30.7	90	93	89	86	82	80	77	71	49				
400	1	AX71A-48	20	2.64	1385	5.67	27.1	92	92	92	90	89	86	83	79	52				
	2	AX71AY-48	25	2.64	1385	5.67	27.1	93	93	93	91	90	87	84	80	53				
	3	AX71AY-48	30	3.6	1400	7.59	39.1	95	95	95	93	92	89	86	82	55				
	4	AX71AY-48	35	4.8	1425	9.74	51	96	96	96	94	93	90	87	83	56				

710mm Ø 6 POLE

	CURVE	FAN CODE	BLADE ANGLE °	MOTOR RATING (KW)	RPM SPEED	FLC	SC (DOL)	MOTOR CURRENTS								SOUND POWER LEVELS RE 1 PWATT (Hz) INDUCT INLET				dB(A) @3M
								63	125	250	500	1K	2K	4K	8K	63	125	250	500	
300	1	AX7100-67	20	0.66	930	1.81	7.29	74	78	79	76	76	72	66	57	38				
	2	AX71O-67	25	0.66	930	1.81	7.29	73	77	76	75	74	70	67	58	37				
	3	AX71O-67	30	0.66	930	1.81	7.29	78	79	78	78	73	69	66	58	37				
	4	AX71AD-67	40	1.32	925	3.17	14.5	79	79	78	77	73	71	65	58	39				
400	1	AX71AY-68	15	0.66	910	1.81	7.29	79	79	79	76	74	70	67	61	38				
	2	AX71AY-68	20	0.66	910	1.81	7.29	63	81	81	78	76	72	69	63	40				
	3	AX71AY-68	25	0.9	900	2.34	8.63	83	83	83	80	78	74	71	65	42				



For High Pressure range refer to page 28.

800mm Ø

4 POLE

6 POLE



Details illustrated are a small representation of the complete range. Please contact Nuair for selections specific to your project applications and/or request software download.

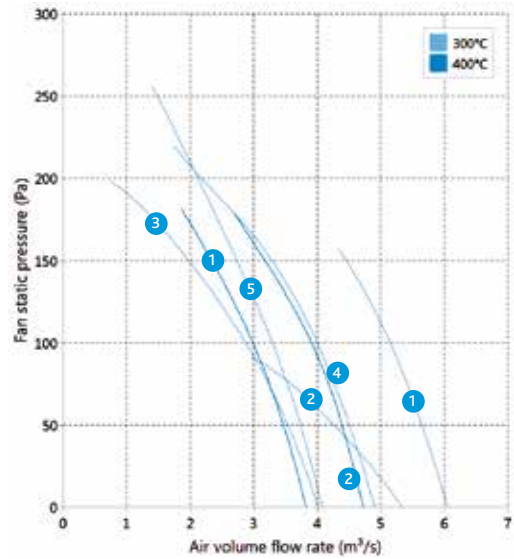
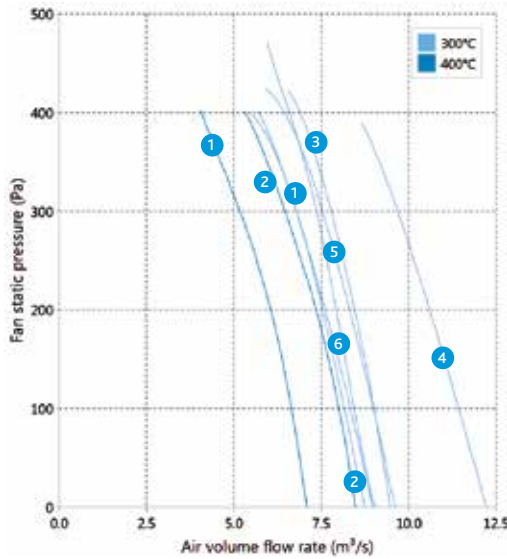

800mm Ø 4 POLE

	CURVE	FAN CODE	BLADE ANGLE °	MOTOR RATING (KW)	RPM SPEED	FLC	SC (DOL)	MOTOR CURRENTS								SOUND POWER LEVELS RE 1 PWATT (Hz) INDUCT INLET				dB(A) @3M
								63	125	250	500	1K	2K	4K	8K	63	125	250	500	
300	1	AX80AA-47	35	6.6	1465	12.6	86.6	87	85	92	89	87	83	81	75	53				
	2	AX82S-47	40	9	1465	17.5	99	94	96	95	94	90	86	82	78	53				
	3	AX80AD-47	50	18	1455	33.7	201	93	88	96	92	89	87	84	80	55				
	4	AX80AG-47	40	9	1465	17.5	99	91	90	96	95	90	87	84	78	54				
	5	AX80DG-47	30	6.6	1465	12.5	76.5	88	95	93	89	86	79	75	70	50				
	6	AX80P-47	37.5	4.8	1430	9.74	51	88	84	91	89	87	84	82	77	53				
400	1	AX80AZ-48	20	3.6	1410	7.59	39.1	96	94	95	93	92	90	86	80	56				
	2	AX80AZ-48	25	3.45	1430	7.59	52.4	96	94	95	93	92	90	86	80	56				

800mm Ø 6 POLE

	CURVE	FAN CODE	BLADE ANGLE °	MOTOR RATING (KW)	RPM SPEED	FLC	SC (DOL)	MOTOR CURRENTS								SOUND POWER LEVELS RE 1 PWATT (Hz) INDUCT INLET				dB(A) @3M
								63	125	250	500	1K	2K	4K	8K	63	125	250	500	
300	1	AX80AA-67	30	1.32	925	3.17	14.5	79	93	86	83	78	74	70	61	47				
	2	AX80AG-67	40	2.53	940	6.18	28.1	81	82	84	81	78	76	72	65	44				
	3	AX80DG-67	20	1.32	925	3.17	14.5	85	89	81	79	73	67	62	54	40				
	4	AX80N-67	37.5	1.32	920	3.17	14.5	94	79	81	79	73	72	67	60	39				
	5	AX80P-67	25	1.32	940	3.17	14.5	72	82	75	77	76	75	71	60	40				
400	1	AX80AZ-68	15	1.32	925	3.17	14.5	82	80	80	78	75	74	70	66	40				
	2	AX80AZ-68	20	1.32	925	3.17	14.5	85	83	83	81	78	77	73	69	43				



For High Pressure range refer to page 29.

900mm Ø

4 POLE

6 POLE



Details illustrated are a small representation of the complete range. Please contact Nuair for selections specific to your project applications and/or request software download.

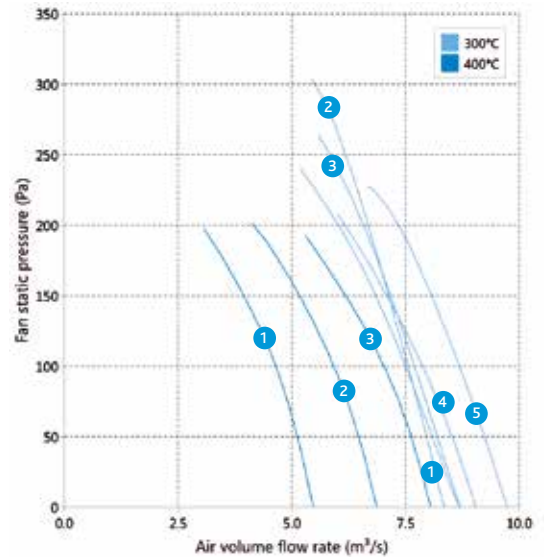
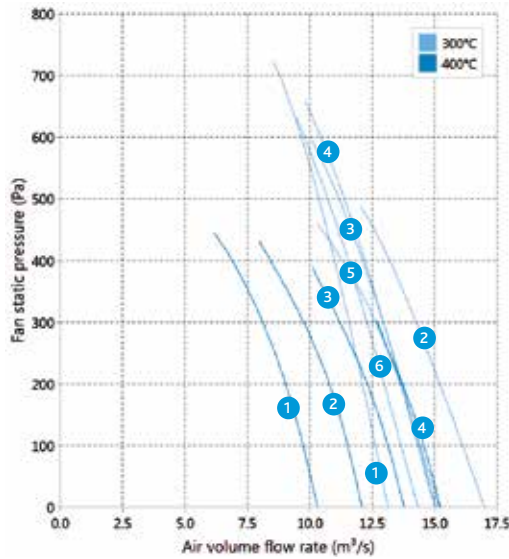

900mm Ø 4 POLE

	CURVE	FAN CODE	BLADE ANGLE °	MOTOR RATING (KW)	RPM SPEED	FLC	SC (DOL)	MOTOR CURRENTS								SOUND POWER LEVELS RE 1 PWATT (Hz) INDUCT INLET				dB(A) @3M
								63	125	250	500	1K	2K	4K	8K	63	125	250	500	
300	1	AX90AA-47	45	13.2	1455	26.3	132	98	91	100	100	98	92	89	83	63				
	2	AX90AD-47	50	22.2	1470	42.1	232	97	92	100	96	93	91	87	84	59				
	3	AX90AG-47	45	26.4	1470	49.8	275	97	94	96	97	93	89	85	80	58				
	4	AX90DG-47	35	13.2	1450	26.3	132	97	99	96	95	91	86	84	80	55				
	5	AX90DG-47	37	13.2	1450	26.3	132	97	100	95	94	91	86	84	81	55				
	6	AX90DJ-47	30	13.2	1450	25.3	136	97	95	100	98	91	85	82	77	59				
400	1	AX90AZ-48	20	6.6	1435	12.8	72.4	97	97	97	95	92	91	88	84	57				
	2	AX90AZ-48	25	9	1440	17.5	99	101	101	99	96	95	92	88	61					
	3	AX90AZ-48	30	10.6	1445	19.9	133	103	103	101	98	97	94	90	63					
	4	AX90AX-48	35	13.2	1450	26.3	132	106	106	106	104	101	100	97	93	66				

900mm Ø 6 POLE

	CURVE	FAN CODE	BLADE ANGLE °	MOTOR RATING (KW)	RPM SPEED	FLC	SC (DOL)	MOTOR CURRENTS								SOUND POWER LEVELS RE 1 PWATT (Hz) INDUCT INLET				dB(A) @3M
								63	125	250	500	1K	2K	4K	8K	63	125	250	500	
300	1	AX90DH-67	33	2.64	925	6.18	26.5	101	95	88	87	81	76	73	70	49				
	2	AX90DJ-67	28	3.6	940	8.38	36.8	90	92	90	88	80	74	69	62	50				
	3	AX90DG-67	31	2.53	925	6.18	28.1	89	90	88	88	81	75	70	65	46				
	4	AX90AA-67	40	2.53	925	6.18	28.1	88	90	87	90	88	85	79	69	52				
	5	AX90AG-67	45	6.6	955	14.9	90.4	89	88	90	87	83	79	75	70	50				
400	1	AX90AZ-68	15	1.32	905	3.17	14.5	88	86	86	84	82	78	76	72	46				
	2	AX90AZ-68	20	1.8	900	4.54	17.2	89	88	90	87	83	79	75	70	50				
	3	AX90AZ-68	25	2.53	925	6.18	28.1	88	86	86	84	82	78	76	72	46				



For High Pressure range refer to page 29.

1000mm Ø

4 POLE

6 POLE



Details illustrated are a small representation of the complete range. Please contact Nuaire for selections specific to your project applications and/or request software download.

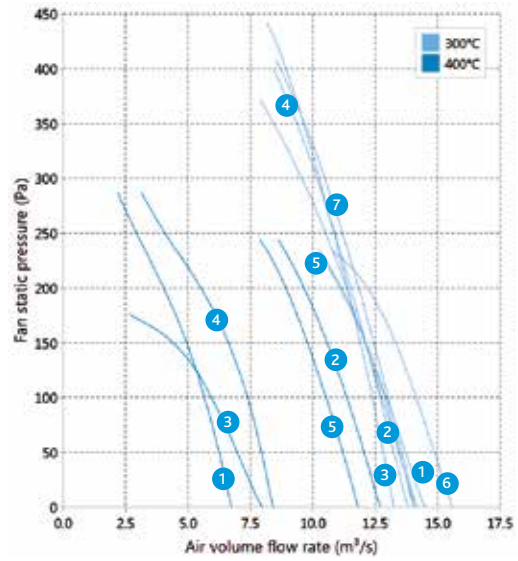
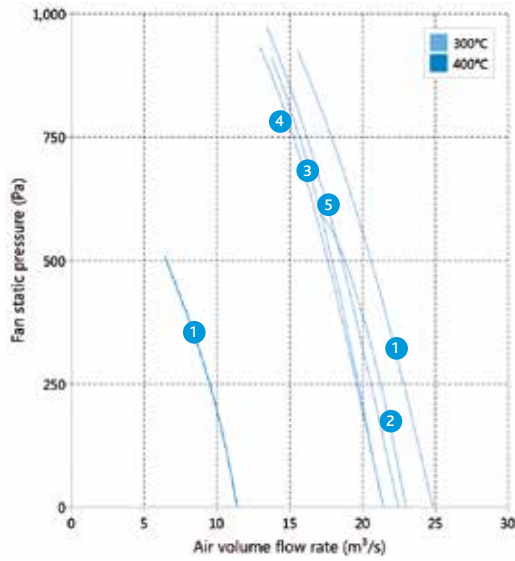

1000mm Ø 4 POLE

	CURVE	FAN CODE	BLADE ANGLE °	MOTOR RATING (KW)	RPM SPEED	MOTOR CURRENTS		SOUND POWER LEVELS RE 1 PWATT (Hz) INDUCT INLET								dB(A) @3M
						FLC	SC (DOL)	63	125	250	500	1K	2K	4K	8K	
300	1	AX100AG-47	50	34.5	1450	66.3	389	101	103	101	103	101	97	94	88	63
	2	AX100CX-47	40	26.4	1455	49.8	275	98	104	100	98	96	92	91	86	61
	3	AX100CX-47	45	34.5	1450	66.3	389	99	103	103	101	98	94	94	91	64
400	4	AX100CX-47	38	26.4	1455	49.8	275	98	103	99	97	95	91	90	85	60
	5	AX100DJ-47	38	26.4	1455	49.5	276	99	97	104	102	97	92	91	86	64
	1	AX100AZ-48	15°	9	1440	17.5	99	99	99	99	96	93	90	88	86	58

1000mm Ø 6 POLE

	CURVE	FAN CODE	BLADE ANGLE °	MOTOR RATING (KW)	RPM SPEED	MOTOR CURRENTS		SOUND POWER LEVELS RE 1 PWATT (Hz) INDUCT INLET								dB(A) @3M
						FLC	SC (DOL)	63	125	250	500	1K	2K	4K	8K	
300	1	AX100AG-67	45	9	955	18.4	82.7	92	93	90	93	90	85	82	71	51
	2	AX100AG-67	50	11	965	22.3	106	92	101	94	94	93	88	83	76	54
	3	AX100CX-67	37	9	970	18.4	82.7	92	94	88	89	85	81	77	72	50
	4	AX100CX-67	38	6.33	960	14.5	80.7	92	95	89	89	85	81	78	72	50
	5	AX100CY-67	42	9	970	18.4	82.7	103	91	95	91	87	83	80	76	54
	6	AX100CZ-67	35	6.33	960	14.5	80.7	92	91	95	94	87	82	78	71	55
	7	AZ100DJ-67	42	11	965	22.3	106	98	98	106	96	89	86	85	81	63
400	1	AX100AZ-68	15	2.53	940	6.18	28.1	85	84	93	91	91	83	79	74	54
	2	AX100AZ-68	20	2.53	940	6.18	28.1	88	86	94	91	89	82	78	73	54
	3	AX100AZ-68	30	6.33	960	14.5	80.7	92	90	97	95	92	83	79	77	56
	4	AX100AZ-68	34	6.6	960	12.8	72.4	93	89	96	94	90	82	79	79	55
	5	AX100BD-68	20	1.8	940	4.54	17.2	86	90	92	89	85	77	74	73	50

1120mm Ø

4 POLE

6 POLE



Details illustrated are a small representation of the complete range. Please contact Nuairé for selections specific to your project applications and/or request software download.

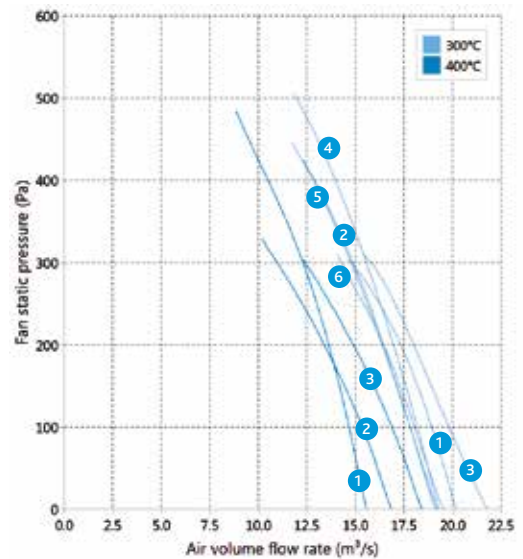
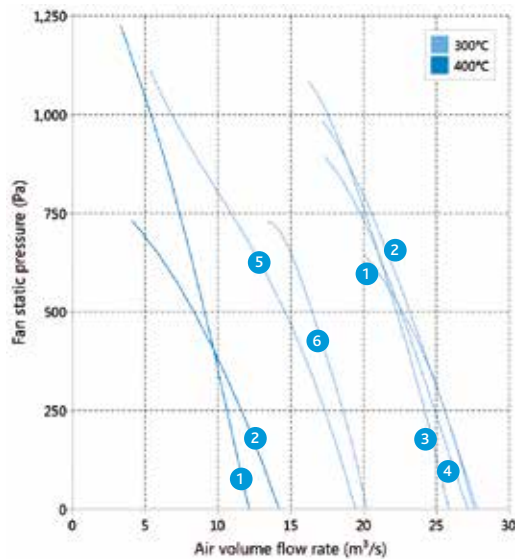

1120mm Ø 4 POLE

	CURVE	FAN CODE	BLADE ANGLE °	MOTOR RATING (KW)	RPM SPEED	FLC	SC (DOL)	MOTOR CURRENTS								SOUND POWER LEVELS RE 1 PWATT (Hz) INDUCT INLET				dB(A) @3M
								63	125	250	500	1K	2K	4K	8K	63	125	250	500	
300	1	AX112AG-47	45	42.6	1470	79.1	452	103	104	100	104	103	98	96	90	64				
	2	AX112CX-47	35	34.5	1460	66.3	389	101	102	100	99	96	92	89	85	60				
	3	AX112CZ-47	32	42.6	1470	79.1	452	101	100	107	105	98	93	91	87	67				
	4	AX112DB-47	35	51.8	1475	92.9	564	103	102	108	102	99	94	93	89	65				
	5	AX112CX-47	25	22.2	1470	41.8	260	95	100	98	100	96	92	90	85	61				
	6	AX112AG-47	35	26.4	1470	49.8	275	96	103	96	101	100	98	95	92	62				
400	1	AX112BA-48	10	13.2	1455	26.3	132	99	101	109	108	107	100	95	91	69				
	2	AX112BE-48	12	10.6	1455	19.9	133	95	108	102	103	101	96	93	90	64				

1120mm Ø 6 POLE

	CURVE	FAN CODE	BLADE ANGLE °	MOTOR RATING (KW)	RPM SPEED	FLC	SC (DOL)	MOTOR CURRENTS								SOUND POWER LEVELS RE 1 PWATT (Hz) INDUCT INLET				dB(A) @3M
								63	125	250	500	1K	2K	4K	8K	63	125	250	500	
300	1	AX112AG-67	45	12.7	965	25.2	128	93	94	91	96	92	88	84	73	54				
	2	AX112AG-67	50	17.3	970	32.8	193	94	104	98	98	95	90	85	79	57				
	3	AX112CX-67	37	12.7	965	25.2	128	97	98	92	91	89	83	79	75	52				
	4	AX112CZ-67	37	13.2	970	25.2	156	95	94	97	96	90	86	81	76	57				
	5	AX112DJ-67	36	11	965	22.3	106	97	96	99	94	89	85	81	75	58				
	6	AX112DL-67	40	18	965	34.1	217	101	99	104	99	92	89	88	85	61				
400	1	AX112BA-68	25	13.2	970	26.3	127	94	90	103	97	93	87	82	79	60				
	2	AX112BE-68	30	9	970	18.4	82.7	97	93	96	92	89	84	82	82	55				
	3	AX112BE-68	35	13.2	970	26.3	127	103	98	102	96	92	86	82	81	59				

1250mm Ø

4 POLE

6 POLE



Details illustrated are a small representation of the complete range. Please contact Nuair for selections specific to your project applications and/or request software download.

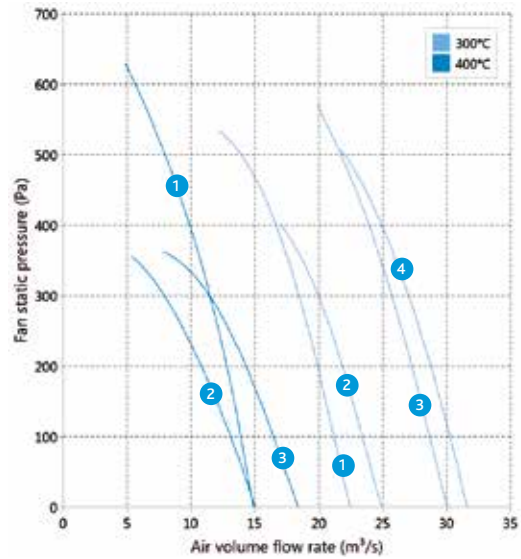
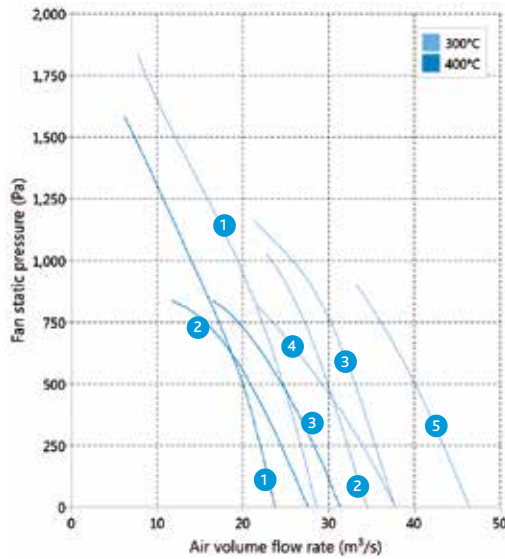

1250mm Ø 4 POLE

	CURVE	FAN CODE	BLADE ANGLE °	MOTOR RATING (KW)	RPM SPEED	FLC	SC (DOL)	MOTOR CURRENTS		SOUND POWER LEVELS RE 1 PWATT (Hz) INDUCT INLET						dB(A) @3M
								63	125	250	500	1K	2K	4K	8K	
300	1	AX125DB-47	25	54	1475	97.4	606	106	118	121	113	105	99	94	89	78
	2	AX125DB-47	30	51.8	1475	92.9	564	104	108	113	114	108	101	95	90	72
	3	AX125DJ-47	35	63.6	1475	112	631	104	104	112	113	106	101	99	96	74
	4	AX125CW-47	40	34.5	1460	65.1	367	110	106	107	104	99	97	96	95	66
	5	AX125CZ-47	45	104	1485	186	1097	106	106	112	109	103	101	100	98	71
400	1	AX125CV-48	15	36	1470	67.8	428	99	104	109	110	108	104	100	96	70
	2	AX125BE-48	20	26.4	1470	49.5	276	105	112	107	108	101	97	96	95	67
	3	AX125BE-48	25	34.5	1460	66.3	389	106	109	107	108	101	97	96	96	67

1250mm Ø 6 POLE

	CURVE	FAN CODE	BLADE ANGLE °	MOTOR RATING (KW)	RPM SPEED	FLC	SC (DOL)	MOTOR CURRENTS		SOUND POWER LEVELS RE 1 PWATT (Hz) INDUCT INLET						dB(A) @3M
								63	125	250	500	1K	2K	4K	8K	
300	1	AX125CZ-67	30	12.7	965	25.2	128	97	102	103	102	97	88	83	79	61
	2	AX125DL-67	35	22.2	975	43.1	203	101	100	104	99	93	90	89	87	65
	3	AX125CZ-67	40	26.4	975	51.1	271	97	101	101	99	95	89	86	79	60
	4	AX125DJ-67	45	36	985	66.8	420	98	103	104	101	98	93	89	85	66
400	1	AX125BA-68	15	9	970	18.4	82.7	95	91	103	99	98	91	85	82	61
	2	AX125BE-68	15	6.33	960	14.5	80.7	95	97	100	97	94	87	82	80	58
	3	AX125BE-68	20	6.33	960	14.5	80.7	99	100	100	98	93	86	83	82	58

1400mm Ø

6 POLE

1500mm Ø

6 POLE



Details illustrated are a small representation of the complete range. Please contact Nuairé for selections specific to your project applications and/or request software download.

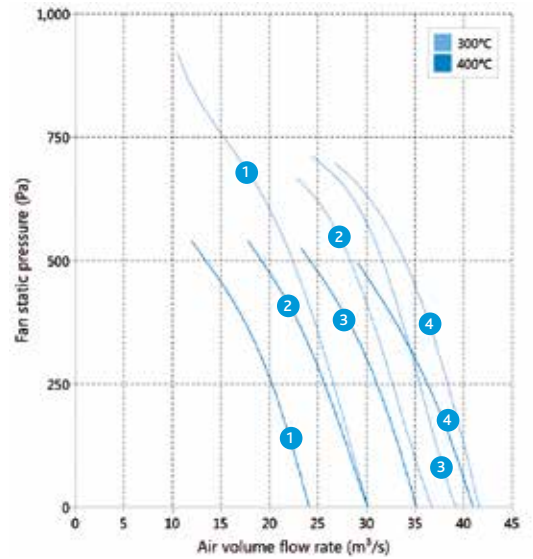
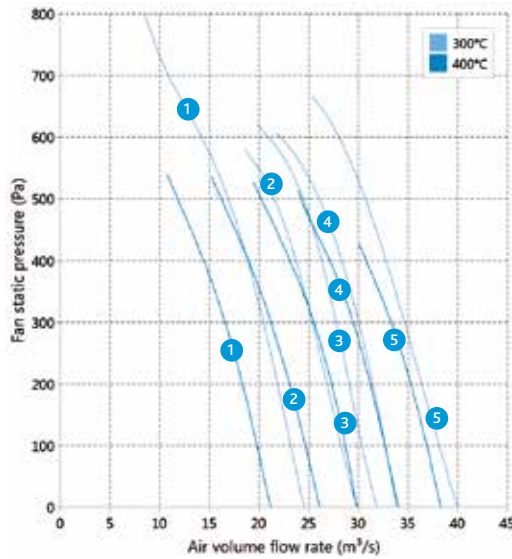

1400mm Ø 6 POLE

	CURVE	FAN CODE	BLADE ANGLE °	MOTOR RATING (KW)	RPM SPEED	FLC	SC (DOL)	MOTOR CURRENTS								SOUND POWER LEVELS RE 1 PWATT (Hz) INDUCT INLET				dB(A) @3M
								63	125	250	500	1K	2K	4K	8K	63	125	250	500	
300	1	AX140DB-67	25	13.2	970	26.6	132	100	95	97	98	101	98	93	87	61				
	2	AX140DB-67	30	22.2	975	43.1	203	98	96	103	103	101	96	91	85	61				
	3	AX140DB-67	32.5	22.2	975	43.1	203	96	103	103	101	99	95	92	87	64				
	4	AX140DB-67	35	36	985	67.2	379	100	106	105	103	98	93	88	82	65				
	5	AX140DB-67	40	36	985	67.2	379	101	98	103	105	102	101	97	89	62				
400	1	AX140BA-68	15	13.2	970	27.9	160	100	100	100	98	96	94	91	86	61				
	2	AX140BA-68	20	18	965	34.2	192	103	103	102	101	99	96	94	89	64				
	3	AX140BA-68	25	26.4	975	51.6	256	104	104	104	102	100	98	95	90	65				
	4	AX140BA-68	30	26.4	975	51.6	256	104	104	103	102	100	97	95	90	65				
	5	AX140BA-68	35	34.5	985	64.5	375	105	105	105	103	101	99	96	91	66				

1500mm Ø 6 POLE

	CURVE	FAN CODE	BLADE ANGLE °	MOTOR RATING (KW)	RPM SPEED	FLC	SC (DOL)	MOTOR CURRENTS								SOUND POWER LEVELS RE 1 PWATT (Hz) INDUCT INLET				dB(A) @3M
								63	125	250	500	1K	2K	4K	8K	63	125	250	500	
300	1	AX150DB-67	25	22.2	975	43.1	203	102	98	101	101	103	100	94	89	63				
	2	AX150DB-67	30	36	985	67.2	379	101	100	108	108	105	99	94	87	64				
	3	AX150DB-67	32.5	44.4	980	81.4	447	99	108	107	104	101	97	93	88	67				
	4	AX150DB-67	35	44.4	980	81.4	447	104	111	108	105	100	95	89	85	69				
400	1	AX150BA-68	15	18	965	33.7	195	104	104	101	100	97	96	95	89	60				
	2	AX150BA-68	20	22.2	975	43.1	203	106	106	103	102	99	98	97	91	62				
	3	AX150BA-68	25	26.4	975	51.1	254	108	108	105	104	101	100	99	93	64				
	4	AX150BA-68	30	44.4	980	81.4	447	110	110	107	106	103	102	101	95	66				

1600mm Ø

6 POLE



Details illustrated are a small representation of the complete range. Please contact Nuairé for selections specific to your project applications and/or request software download.

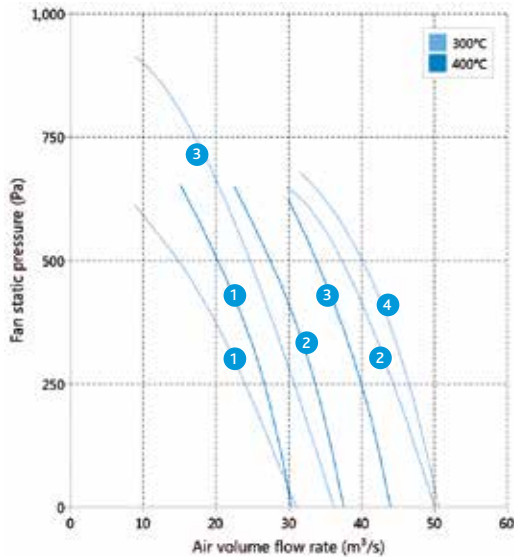

1600mm Ø 6 POLE

	CURVE	FAN CODE	BLADE ANGLE °	MOTOR RATING (KW)	RPM SPEED	FLC	SC (DOL)	MOTOR CURRENTS								SOUND POWER LEVELS RE 1 PWATT (Hz) INDUCT INLET				dB(A) @3M
								63	125	250	500	1K	2K	4K	8K	63	125	250	500	
300	1	AX160CX-67	25	12.7	965	25.2	128	96	105	101	101	97	93	89	84	62				
	2	AX160CZ-67	35	54	985	104	528	99	110	112	110	104	97	96	94	71				
	3	AX160DB-67	25	22.2	975	43.8	209	92	105	101	101	97	92	91	91	63				
	4	AX160DB-67	35	54	985	104	528	101	110	115	110	105	98	96	94	73				
400	1	AX160BA-68	15	22.2	975	43.1	203	106	107	104	101	99	98	95	91	62				
	2	AX160BA-68	20	36	985	67.2	379	109	110	107	104	102	101	98	94	65				
	4	AX160BA-68	25	44.4	980	81.9	484	111	112	109	106	104	103	100	96	67				

We can help.

For selections requiring a unit size greater than 1600mm diameter, please contact Nuairé for your fan selections tailored to your project and applications requirements.

The curves shown in this catalogue are not limited only to the products shown here, and show a small selection of the capabilities of Nuairé.

For additional selections, please contact Nuairé on +44(0)29 2085 8484, or download the selection software from www.nuairegroup.com



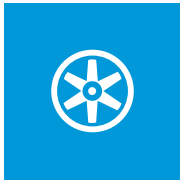

AXUS ANCILLARIES

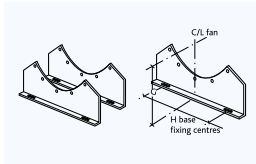

MOUNTING BRACKETS*

The AXUS mounting brackets are manufactured from heavy gauge galvanised steel and are supplied in pairs.

Typical Code - CMB100
(100 = Fan diameter in cm).

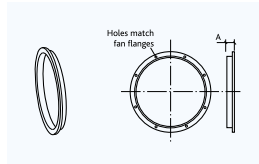

MATCHING FLANGE (SINGLE)*

Manufactured from galvanised steel. Matching flanges are supplied individually.

Typical Code: CMF100
(100 = fan diameter in cm).

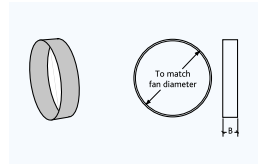

FLEXIBLE CONNECTOR (SINGLE)*

Circular without flanges. Flexible duct material is flameproof and resistant to heat up to 132°C/400°C, chemicals, ozone, oil and grease. The material is airtight, waterproof and tested to BS476 Part 7. (Supplied complete with fixing straps).

Typical Code: CFC100
(100 = fan diameter in cm) - 132°C. **CFCH100** (100 = fan diameter in cm) - 400°C.

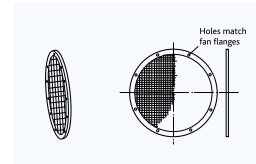

GUARD*

Manufactured from heavy gauge galvanised steel and acid zinc plated steel mesh. Standard Accessory Losses (k). Flat type • Finger guard 0.4.

Typical Code: CGD100
(100 = fan diameter in cm). Pressure Drop (Pa) = 0.6 x k x Velocity (m/s).

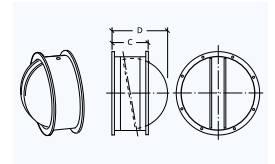

BACKDRAUGHT DAMPER (SINGLE)*

Gravity operated backdraught damper, manufactured from heavy gauge galvanised steel with a pair of bolted flanges. Standard Accessory Losses (k) (Air stream operated) 0.4.

Typical Code: CBD100
(100 = fan diameter in cm) - 132°C. (For horizontal mounting only). Pressure Drop (Pa) = 0.6 x k x Velocity (m/s).

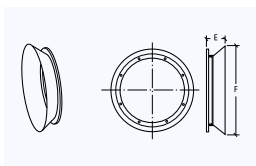

INLET CONE*

Manufactured in heavy gauge galvanised steel with a single bolted flange. Standard Accessory Losses (k). Low loss • Inlet cone 0.38.

Typical Code: CIC100
(100 = fan diameter in cm). Pressure Drop (Pa) = 0.6 x k x Velocity (m/s).

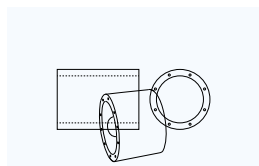

ATTENUATOR*

Standard (non podded), long (non podded), podded, and long podded options available. Conical Inlet silencer available upon request.

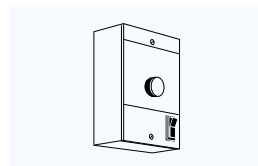

CONTROLS*

Choice of inverter, electronic or transformer speed controls available.

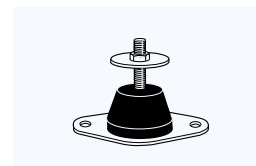

ANTI-VIBRATION MOUNTS*

Resilient rubber, for fan only. Spring options also available.

Typical code: NAV1.

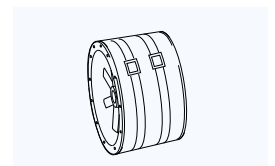

ACOUSTIC JACKET*

Acoustic material laminated with 25mm foam. Complete with straps/buckles for security.

*For dimensional information, please contact Nuairé.



HIGH TEMPERATURE AND AMBIENT HIGH PRESSURE AXIAL RANGE

The AXUS high pressure range of axial flow fans are designed for 'in-duct' applications. Manufactured from mild steel and then galvanised, making the unit suitable for indoor and outdoor applications.



KEY BENEFITS:

- **HOT DIPPED GALVANISED STEEL CONSTRUCTION** - ENSURING STRENGTH, DURABILITY & PROTECTION
- **HIGH PERFORMANCE** - DUTY UP TO 25M³/S WITH PRESSURE UP TO 2000 PA
- **HIGH TEMPERATURE** - INDEPENDENTLY TESTED TO EN12101-3
- **FLEXIBLE SOLUTION** - SUITABLE FOR INTERNAL & EXTERNAL APPLICATIONS, & VERTICALLY OR HORIZONTALLY
- **TESTED TO HIGHEST STANDARDS** - AIR PERFORMANCE TO ISO 5801 (PART 1) 2017
- **AMCA APPROVED LABS** - BOTH TYPE 'A' & 'D' LABORATORIES AT NUAIRE ARE ACCREDITED TO THE AMCA STANDARD





CONSULTANT SPECIFICATION



CASING

Long cased covering both the motor and impeller, manufactured from heavy gauge galvanised steel (HDG), corrosion resistant to BS EN10142 1991 with integral formed inlet and outlet mounting flange, with pre-drilled bolt holes.

Cases are fitted with integral case mounted guide vanes– providing performance-enhancing characteristics.

Case material options available: Painted: Polyester powder and epoxy



PERFORMANCE

Up to 25m³/s, 2000 Pa duty range.



CERTIFICATION AND OPERATING TEMPERATURE

Suitable for day to day environmental extract up to a maximum of 60°C and one-off emergency extract for either 300°C or 400°C for 2 hours depending on local fire code. Suitable for smoke reservoir and non-smoke reservoir applications.



MOTOR

Motors incorporated are full cast TEAO (Totally Enclosed, Air Over) with Class H insulation, IP55 protection, suitable to operate for day to day environmental extract (up to 60°C) and one-off emergency extract, either 300°C or 400°C for 2 hours (S2), depending on the project requirements.

Motors are available in a range of efficiency classifications: IE1, IE2, IE3 all tested & certified as a component of the complete fan assembly to EN12101-3. Motors are pre-wired to an external case-mounted terminal box as standard, ensuring ease of installation, protected to dust and water ingress to IP55. Motors are available with additional features in accordance with EN12101-3, such as:

- PTC thermal overload protection
- Anti-condensation heaters.



ANCILLARIES

- Matching flanges
- Flexible connections
- Anti-vibration mounts
- Mounting brackets (additional if required)
- Acoustic jackets (ambient only)
- Attenuators
- Guards
- Inlet cones
- Backdraft dampers
- Controls (ambient only)



IMPELLER

For all temperature classes, ambient, 300°C and 400°C for 2hr, impellers are high efficiency profile, fabricated completely from mild steel mounted in a steel hub ensuring optimum performance and safety under emergency conditions.



INSTALLATION

Suitable for internal and external operation. The unit should be installed horizontally on the mounting feet as supplied. For alternative mounting arrangements, contact Nuaire. DW/144 and general good practice standards for installation should be taken into consideration at design stage.



APPLICATIONS

- Utility tunnel & service room
- Car parks & smoke
- Industrial
- Boiler rooms
- Lift motor rooms
- Utility & transit tunnels
- Sports halls
- Factories & warehouses
- Hospitals & medical centres
- Offices & commercial
- Supermarkets
- Retail, leisure & sports facilities
- Public buildings

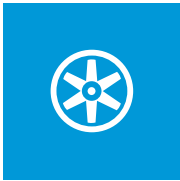

AXIAL - HIGH PRESSURE SINGLE STAGE

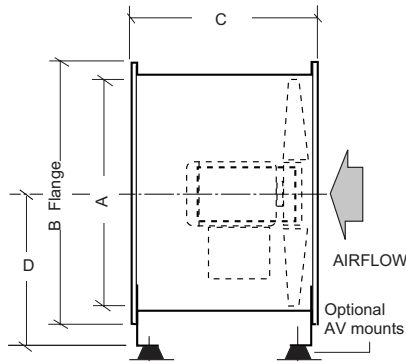

CODING AX63X-XX

AX	63	X	-	X	X
1	2	3	4	5	

SAMPLE CODING

1. Axial fan
2. Size of casing in CM
3. Impeller specification reference
4. Motor speed in poles
5. Operating temperature reference

Contact Nuair for Fan Selector to help in selecting the right unit for your project.

DIMENSIONS (MM)

MODEL	A	B	C	D
AX630	630	740	840	488
AX710	707	817	840	564
AX710	707	817	1043	564
AX800	808	918	840	590
AX800	808	918	1043	590
AX900	909	1019	840	659
AX900	909	1019	1043	659

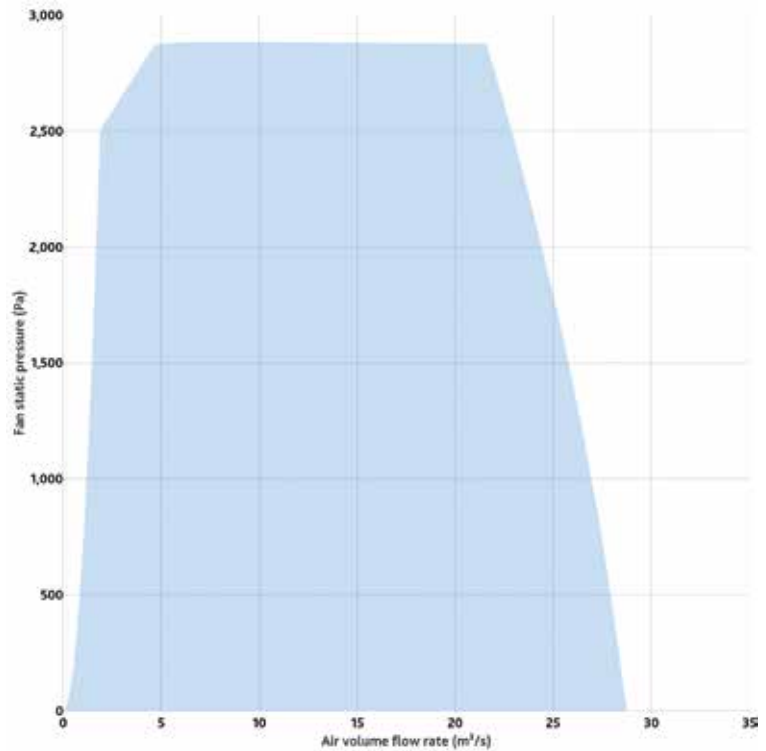

630mm Ø

5 POLE

710mm Ø

5 POLE



Details illustrated are a small representation of the complete range. Please contact Nuairé for selections specific to your project applications and/or request software download.

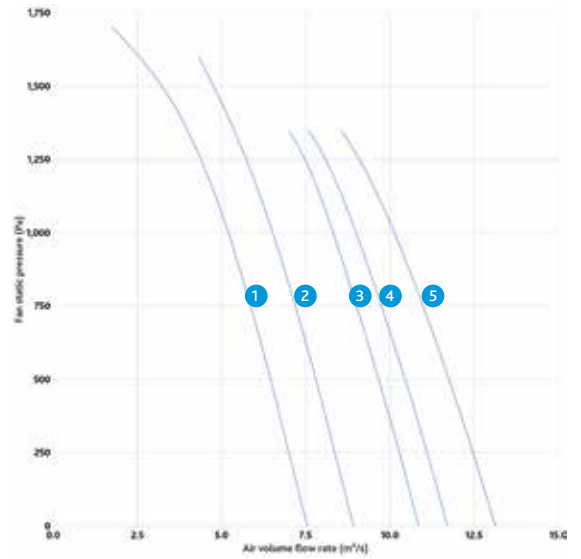
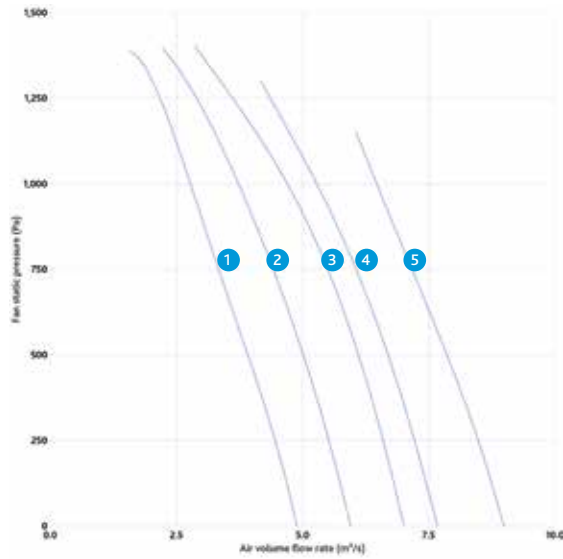

630/710mm Ø 5 POLE

	CURVE	FAN CODE 300/2	FAN CODE 400/2	BLADE ANGLE °	MOTOR RATING (KW)	RPM SPEED	MOTOR CURRENTS		SOUND POWER LEVELS RE 1 PWATT (Hz) INDUCT INLET								dB(A) @3M
							FLC	SC (DOL)	63	125	250	500	1K	2K	4K	8K	
630	1	AX63LQ*27	AX63LQ*28	10	5.5	2910	10.6	72.1	93	92	99	103	106	102	95	89	72
	2	AX63LQ*27	AX63LQ*28	15	7.5	2910	14.1	95.9	98	97	101	107	107	101	95	91	74
	3	AX63LQ*27	AX63LQ*28	20	9.2	2915	17.3	131	101	103	104	111	106	99	95	93	73
	4	AX63LQ*27	AX63LQ*28	23	13.2	2935	24.6	143	103	101	105	107	102	97	93	90	73
	5	AX63LQ*27	AX63LQ*28	29	15	2930	27.6	193	104	101	105	106	103	97	94	92	72
710	1	AX71LQ*27	AX71LQ*28	10	9.2	2915	17.3	131	92	90	104	101	104	103	99	96	74
	2	AX71LQ*27	AX71LQ*28	15	13.2	2935	24.6	143	95	91	104	102	103	101	98	94	72
	3	AX71LQ*27	AX71LQ*28	22	18	2930	33.3	193	101	96	106	103	101	97	95	93	70
	4	AX71LQ*27	AX71LQ*28	25	22.2	2940	39.7	249	102	96	106	104	102	97	95	94	70
	5	AX71LQ*27	AX71LQ*28	30	30	2955	53.6	348	104	97	107	103	103	97	97	96	71



Details illustrated are a small representation of the complete range. Please contact Nuair for selections specific to your project applications and/or request software download.

800mm Ø

4 POLE

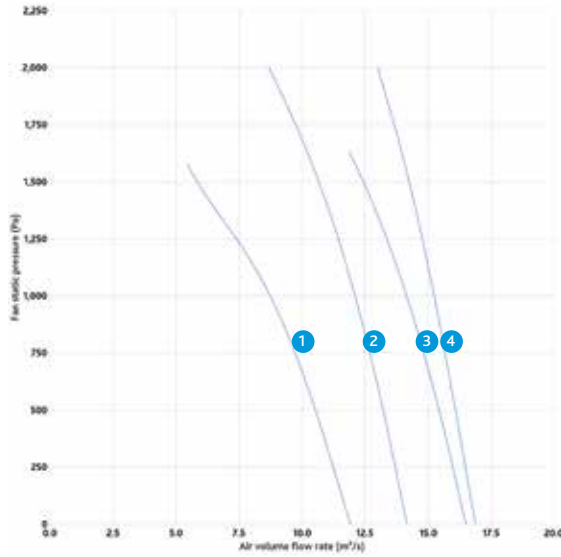

900mm Ø

4 POLE

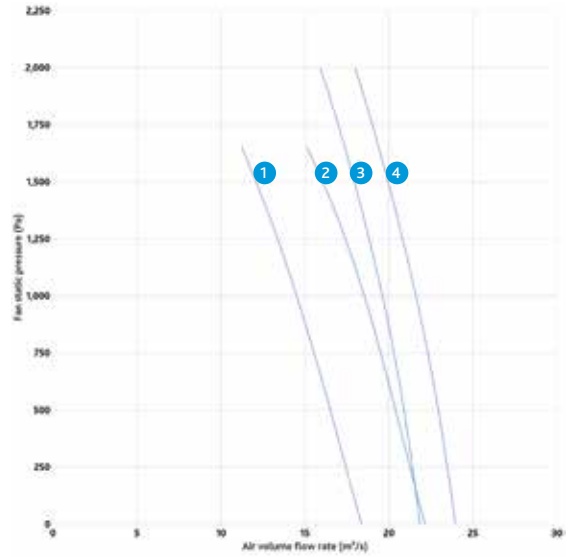

800/900mm Ø 4 POLE

	CURVE	FAN CODE 300/2	FAN CODE 400/2	BLADE ANGLE °	MOTOR RATING (KW)	RPM SPEED	MOTOR CURRENTS		SOUND POWER LEVELS RE 1 PWATT (Hz) INDUCT INLET								dB(A) @3M
							FLC	SC (DOL)	63	125	250	500	1K	2K	4K	8K	
800	1	AX80MA*27	AX80MA*28	17	22	2945	39.1	285	99	96	107	105	105	102	100	98	74
	2	AX80MG*27	AX80MG*28	22	37	2950	65.88	447	106	99	114	108	108	104	102	99	77
	3	AX80MC*27	AX80MC*28	27	55	2960	94.6	662	106	101	103	110	111	104	103	102	77
	4	AX80MI*27	AX80MI*28	29	75	2965	128	1050	107	101	106	113	110	105	103	102	79
900	1	AX90MA*27	AX90MA*28	16	37	2950	65.88	447	102	97	109	110	110	105	103	101	78
	2	AX90MA*27	AX90MA*28	22	55	2960	94.6	662	106	100	113	112	113	108	105	104	80
	3	AX90MC*27	AX90MC*28	22	75	2965	128	1050	107	102	107	115	114	109	105	104	81
	4	AX90MC*27	AX90MC*28	25	90	2975	154	1078	109	104	107	116	116	110	107	105	82



THE COMPLETE VENTILATION SOLUTION

- THE COMPLETE RANGE SOLUTION TAILORED TO MEET YOUR PROJECT REQUIREMENTS WORLDWIDE.
- EXPANSIVE RANGE TO MEET YOUR LOCAL REGULATIONS.
- DESIGNED AND TESTED TO THE RECOGNISED INDUSTRY STANDARD IN AMCA ACCREDITED LABORATORIES.



- AXIAL CONFIGURATOR SOFTWARE PROVIDING THE TAILORED SOLUTION AT YOUR FINGERTIPS.
- PRODUCT DEVELOPMENT AND INNOVATION.
- PEDIGREE RENOWNED WORLDWIDE.
- THE COMPLETE SUPPORT TEAM TO GUIDE AND SUPPORT YOU WITH YOUR HVAC PROJECT REQUIREMENTS.

HIGH TEMPERATURE AXIAL RANGE
300°C/2hrs & 400°C/2hrs

AXIAL RANGE - AMBIENT
VENTILATION SOLUTIONS

60Hz
VENTILATION SOLUTIONS

WORLDWIDE
VENTILATION SOLUTIONS

TO UPDATE

HIGH TEMPERATURE
VENTILATION SOLUTIONS



Notes

A large area of the page is filled with horizontal dotted lines, providing space for handwritten notes.

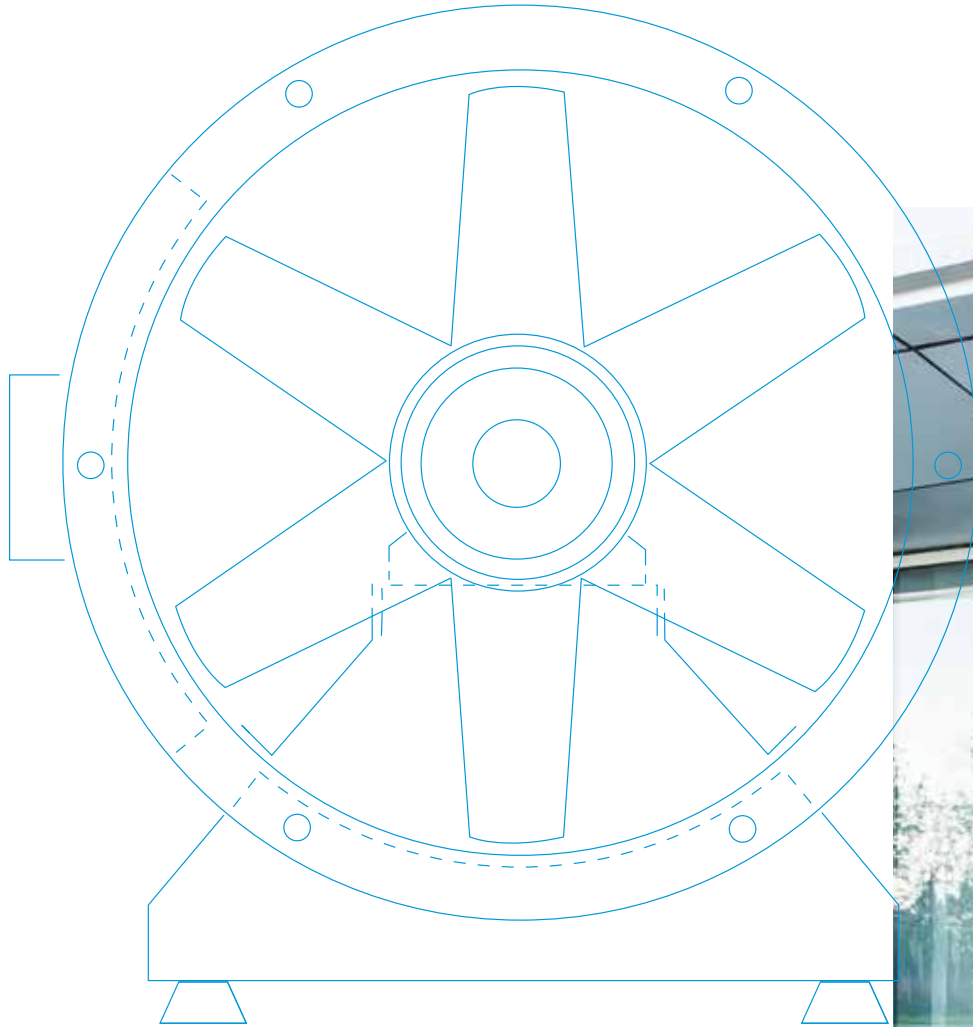

NUAIRE. FOR THE COMPLETE VENTILATION SOLUTION

T +44(0)29 2085 8484 E INTERNATIONAL@NUAIRE.CO.UK W NUAIREGROUP.COM [@NUAIREGROUP](https://twitter.com/NUAIREGROUP)

September 2018.

