

BT-3

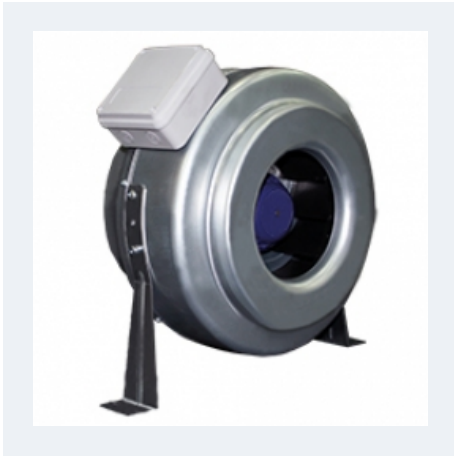

CENTRIFUGAL IN LINE WITH EXTERNAL ROTOR MOTOR

MANUFACTURING FEATURES:

- Housing in galvanized sheet.
- Backward impeller dynamically balanced.
- External connection box.
- Single-phase asynchronous motor with external rotor, including thermal protector for automatic resetting and long-life permanent lubrication ball bearings (40,000 hours). Protection IP-44. Standard voltage 230V 50Hz
- Supplied with support feet (optional mounting)

APPLICATIONS:

Designed for duct installation, suitable for false ceiling, are indicated for:

- Renovation of air in bathrooms and small rooms.
- Maximum continuous working temperature: 50°C.
- Fan not suitable for transporting explosive gases.

ON DEMAND

Fan to work at 60Hz

Accessories



INT



JE 45



REG



REG
VMC



REGD

Technical data

Single-phase motor

Code	Model	R.P.M.	Rated I. (A) 230V	Rated power kW	Max. Airflow m3/h	Sound db (A)**	Weight	Connect. diagram
509810000	BT-3 100	2820	0,32	0,07	250	46	3,16	1
509812500	BT-3 125	2820	0,34	0,08	330	49	3,16	1
509815000	BT-3 150	2770	0,33	0,08	455	43	3,42	1
509816000	BT-3 160	2760	0,34	0,08	455	43	3,44	1
509820000	BT-3 200	2740	0,69	0,16	1.000	47	5,43	1
509825000	BT-3 250	2765	0,66	0,15	1.070	49	5,25	1
509831500	BT-3 315	2730	0,81	0,19	1.540	51	6,57	1

Notes:

** Total sound pressure level at the point of maximum flow measured in dB(A) in the suction measured in free field at a distance of 6m from the source

Dimensions

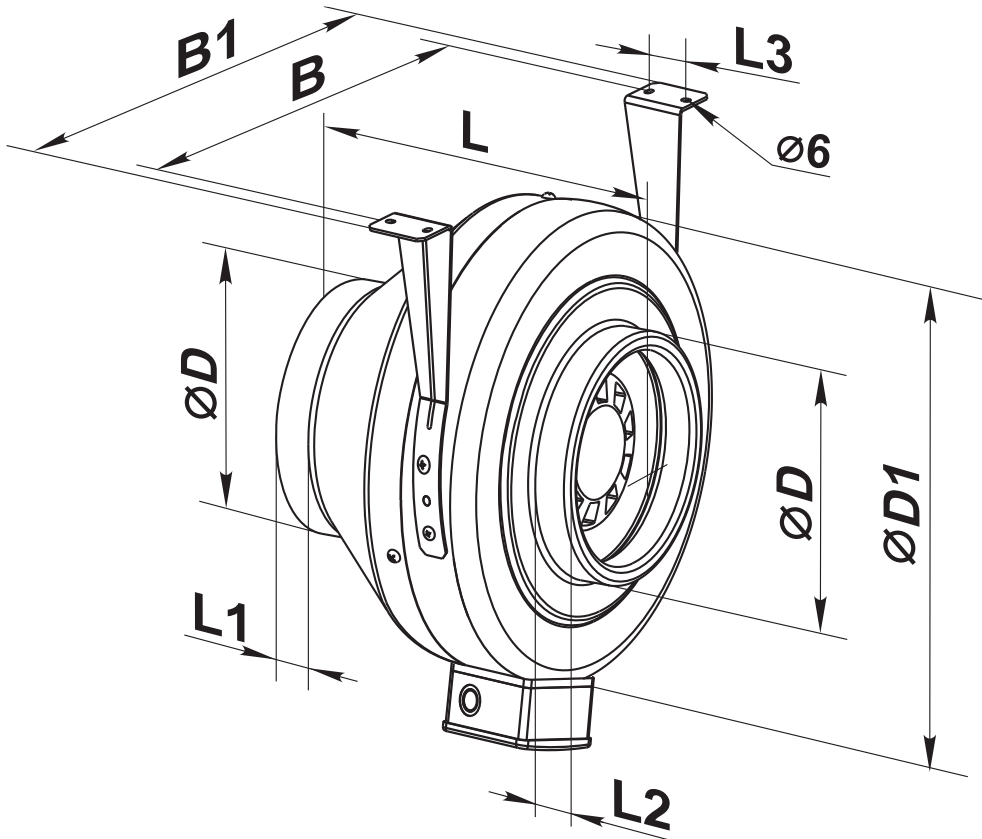

Model	B	B1	L	L1	L2	L3	ØD	ØD1
BT-3 100	253	293	202	23	22	30	98	237
BT-3 125	253	293	202	23	22	30	123	237
BT-3 150	294	334	200	25	23	30	148	278
BT-3 160	294	334	200	25	23	30	158	278
BT-3 200	340	380	245	25	29	40	198	332
BT-3 250	340	380	213	25	29	40	249	332
BT-3 315	410	450	308	33	55	40	313	402

Wiring diagram

DIAGRAM N° 1

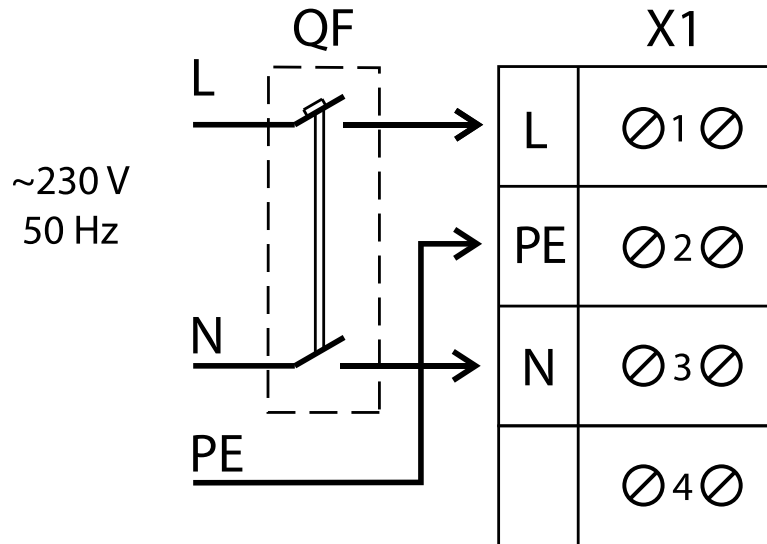

CHARACTERISTIC CURVE

1	BT-3 100	2	BT-3 125	3	BT-3 150	4	BT-3 160
5	BT-3 200	6	BT-3 250	7	BT-3 315		

AIR FLOW - PRESSURE

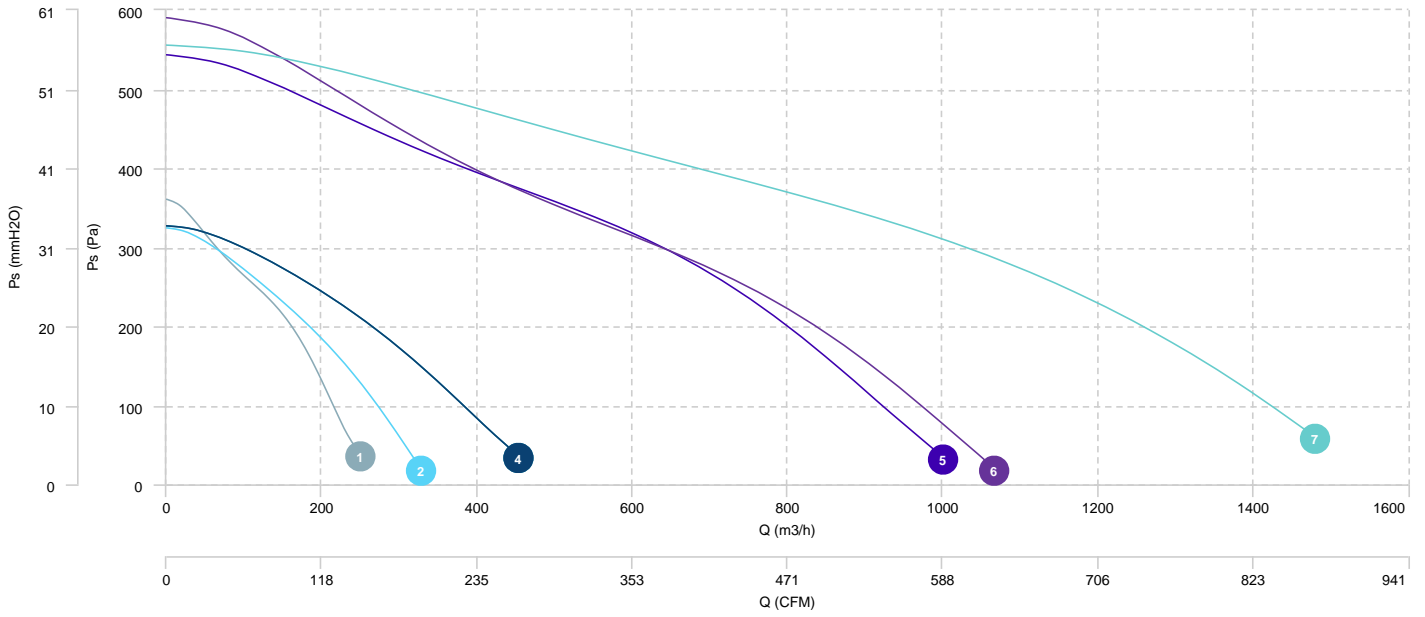

AIR FLOW - ABSORBED POWER

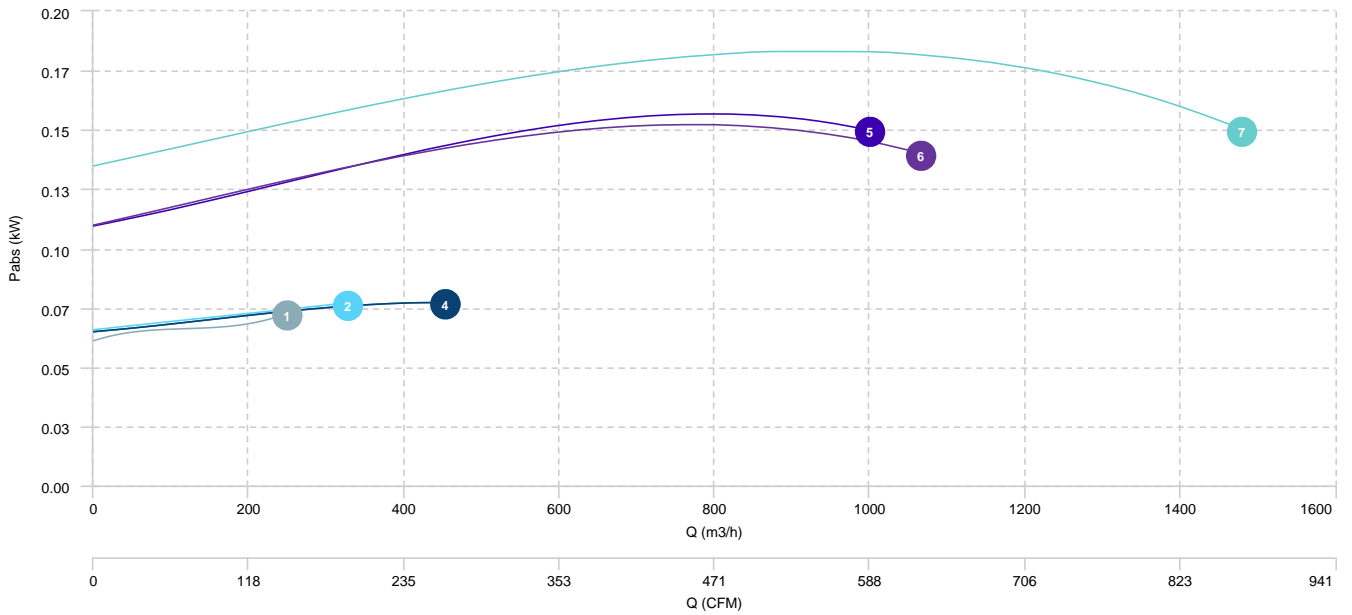

Sound data

Sound power Lw dB (A)										
Model		63 Hz	125 Hz	250 Hz	500 Hz	1000 Hz	2000 Hz	4000 Hz	8000 Hz	Total
BT-3 100	Inlet	47	67	68	67	60	54	53	42	72
	Outlet	56	67	72	66	63	58	57	52	73
	Radiated	43	60	57	41	24	6	17	24	64
BT-3 125	Inlet	56	63	68	69	64	61	52	41	75
	Outlet	58	71	74	72	65	65	56	47	75
	Radiated	52	64	59	48	36	23	30	27	64
BT-3 150	Inlet	42	67	66	63	61	58	48	35	69
	Outlet	46	69	65	68	64	63	50	40	72
	Radiated	41	60	53	36	20	18	30	24	60
BT-3 160	Inlet	42	67	66	63	61	58	48	35	69
	Outlet	46	69	65	68	64	63	50	40	72
	Radiated	41	60	53	36	20	18	30	24	60
BT-3 200	Inlet	51	66	68	71	67	64	58	52	73
	Outlet	51	73	69	74	67	65	60	50	79
	Radiated	47	64	64	46	32	30	44	42	68
BT-3 250	Inlet	60	66	67	67	67	63	56	45	75
	Outlet	60	73	71	69	65	66	59	46	76
	Radiated	58	62	60	47	43	40	47	36	65
BT-3 315	Inlet	53	66	71	69	68	66	63	60	77
	Outlet	58	71	74	72	71	71	63	63	78
	Radiated	55	66	61	57	48	54	56	51	70

erp data

ERP	
Fan type	Unit for non-residential ventilation (LOT 6)
Typology	Unidirectional
Others	None
Type of driver	None

Model	Motor power (kW)	Maximum efficiency point data						
		Eff.Heat recovery (%)	Max. efficiency (%)	Pabs (kW)	Air Flow (m3/h)	Ps (Pa)	Speed (m/s)	SFP (W/m3/s)
BT-3 200	0,16	-	35,59	0,15	558,61	335,57	5.04	965,48
BT-3 250	0,15	-	36,97	0,15	586	320,15	3.4	912,84
BT-3 315	0,19	-	48,31	0,18	902,34	341,18	3.22	730,76