

HMX (ATEX)



ATEX LONG CASE AXIAL

MANUFACTURING FEATURES:

- Reinforced fan casing manufactured in rolling steel sheet.
- Motor-impeller modular assembly for complete versatility.
- Polyester powder finishing coat.
- Cast aluminum impeller with variable pitch angle.
- ATEX standard asynchronous motor. ATEX certified: II2G Ex d, Ex e / II3G Ex nA. IP55 protection and class F insulation. Manufactured with standard voltages: 230/400V 50Hz in three phase motors up to 4kW and 400/690V 50Hz for higher powers.

APPLICATIONS

Designed for wall or duct installation, they are suitable for:

- Air renewal in buildings and industries.
- Smoke extraction (max 45-50°C).
- Maximum working temperature: 50°C
- Ventilation in indoor environments classified as ATEX

Accessories



AC



AVR



AVS



BA-400



BAD



**INT
ATEX**



JE 45



KIT HI



KIT TE



KIT TM



PO



PS



RP



SFC



**SIL-C /
SIL-CN**

UNDER REQUEST

- B-form or 100% reversible impeller.
- 60Hz fans and special voltages.
- ATEX classification for other areas
- Bigger fan sizes.

ORGANISM: L.O.M.

CERTIFICAT N°: LOM 17.755X-C

In compliance with the Directive 2014/34/UE

Technical data

Three-phase motor / 4 poles

Code	Model	Angle	Min. Rated power kW	Max. Rated power kW	Max. Airflow m3/h	Sound db (A)**	Weight t*	Connect. diagram
-	HMX 35 T4 (A0:6)	35° - 40°	0,25	0,25	3.440	46	12,20	1
-	HMX 40 T4 (A0:6)	35° - 40°	0,25	0,25	4.670	51	14,50	1
-	HMX 45 T4 (A0:6)	35° - 40°	0,25	0,25	6.360	52	17,60	1
-	HMX 45 T4 (A5:6)	25° - 45°	0,25	0,55	6.760	51	19,90	1
-	HMX 50 T4 (A0:6)	35° - 40°	0,37	0,37	8.140	53	23,80	1
-	HMX 50 T4 (A5:6)	25° - 45°	0,25	0,75	9.420	54	26,20	1
-	HMX 56 T4 (A5:6)	20° - 45°	0,37	2,20	14.640	70	31,90	1
-	HMX 63 T4 (A5:6)	20° - 45°	0,37	3	20.350	74	36,90	1
-	HMX 71 T4 (A5:6)	20° - 45°	0,75	4	27.520	79	43,60	1
-	HMX 80 T4 (A5:6)	20° - 40°	1,10	4	34.470	71	50,20	1
-	HMX 90 T4 (A6:3)	20° - 42°	3	15	50.950	75	78,90	1
-	HMX 90 T4 (A6:6)	20° - 42°	3	15	58.310	76	84,30	1
-	HMX 100 T4 (A6:3)	20° - 42°	5,50	15	69.340	76	99	1
-	HMX 100 T4 (A6:6)	20° - 42°	5,50	15	81.210	80	105,10	1
-	HMX 112 T4 (A6:3)	20° - 42°	5,50	15	92.050	78	122,60	1
-	HMX 112 T4 (A6:6)	20° - 42°	5,50	15	109.010	83	129,30	1
-	HMX 125 T4 (A7:4)	20° - 42°	7,50	15	132.010	85	142,80	1
-	HMX 125 T4 (A7:8)	20° - 42°	11	15	151.010	89	151,90	1

Three-phase motor / 6 poles

Code	Model	Angle	Min. Rated power kW	Max. Rated power kW	Max. Airflow m3/h	Sound db (A)**	Weight t*	Connect. diagram
-	HMX 40 T6 (A0:6)	35° - 40°	0,25	0,25	3.030	42	14,50	1
-	HMX 45 T6 (A0:6)	35° - 40°	0,25	0,25	4.120	42	17,60	1
-	HMX 45 T6 (A5:6)	25° - 45°	0,25	0,25	4.380	42	19,90	1
-	HMX 50 T6 (A0:6)	35° - 40°	0,25	0,25	5.270	44	23,80	1
-	HMX 50 T6 (A5:6)	25° - 45°	0,25	0,25	6.100	45	26,20	1
-	HMX 56 T6 (A5:6)	20° - 45°	0,25	0,55	9.760	67	31,90	1
-	HMX 63 T6 (A5:6)	20° - 45°	0,37	0,75	13.570	71	36,90	1
-	HMX 71 T6 (A5:6)	20° - 45°	0,37	1,10	18.350	76	43,60	1

Code	Model	Angle	Min. Rated power kW	Max. Rated power kW	Max. Airflow m ³ /h	Sound db (A)**	Weight t*	Connect. diagram
-	HMX 80 T6 (A5:6)	20° - 45°	0,75	2,20	25.190	72	50,20	1
-	HMX 90 T6 (A6:3)	20° - 42°	0,75	4	33.010	65	78,90	1
-	HMX 90 T6 (A6:6)	20° - 42°	0,75	4	37.810	66	84,30	1
-	HMX 100 T6 (A6:3)	20° - 42°	1,10	7,50	44.970	66	99	1
-	HMX 100 T6 (A6:6)	20° - 42°	1,10	7,50	52.610	70	105,10	1
-	HMX 112 T6 (A6:3)	20° - 42°	1,50	11	59.660	69	122,60	1
-	HMX 112 T6 (A6:6)	20° - 42°	1,50	11	70.510	73	129,30	1
-	HMX 125 T6 (A7:4)	20° - 42°	2,20	11	85.410	76	142,80	1
-	HMX 125 T6 (A7:8)	20° - 42°	3	11	98.110	80	151,90	1

Notes:

* The motor is not included in fan weight

** Total sound pressure level at the point of maximum flow measured in dB(A) in the suction measured in free field at a distance of 6m from the source

Dimensions

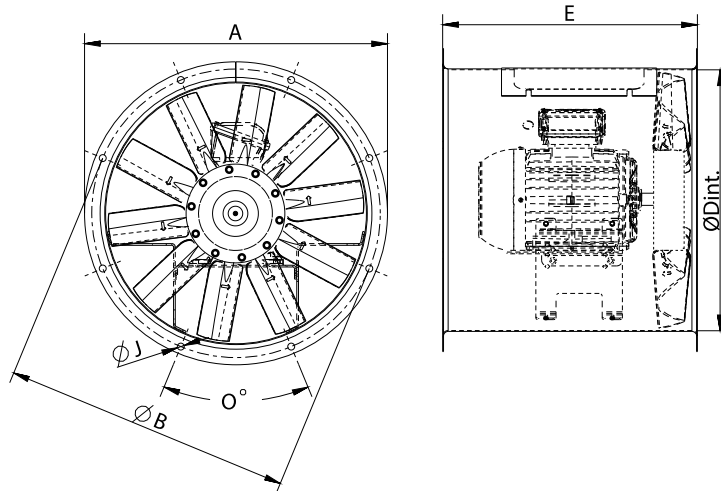

Model	E	O	ØA	ØB	ØD	ØJ
HMX 35 T4 (A0:6)	350	8x45°	434	395	365	10
HMX 40 T4 (A0:6)	440	8x45°	472	450	403	10
HMX 40 T6 (A0:6)	440	8x45°	472	450	403	10
HMX 45 T4 (A0:6)	455	8x45°	525	500	452	12
HMX 45 T4 (A5:6)	455	8x45°	525	500	452	12
HMX 45 T6 (A0:6)	455	8x45°	525	500	452	12
HMX 45 T6 (A5:6)	455	8x45°	525	500	452	12
HMX 50 T4 (A0:6)	440	12x30°	600	560	504	12
HMX 50 T4 (A5:6)	440	12x30°	600	560	504	12
HMX 50 T6 (A0:6)	440	12x30°	600	560	504	12
HMX 50 T6 (A5:6)	440	12x30°	600	560	504	12
HMX 56 T4 (A5:6)	560	12x30°	646	620	559	12
HMX 56 T6 (A5:6)	560	12x30°	646	620	559	12
HMX 63 T4 (A5:6)	550	12x30°	725	690	633	12
HMX 63 T6 (A5:6)	550	12x30°	725	690	633	12
HMX 71 T4 (A5:6)	600	16x22,5°	802	770	715	12
HMX 71 T6 (A5:6)	600	16x22,5°	802	770	715	12
HMX 80 T4 (A5:6)	600	16x22,5°	892	860	801	12
HMX 80 T6 (A5:6)	600	16x22,5°	892	860	801	12
HMX 90 T4 (A6:3)	820	16x22,5°	1000	970	903.5	12
HMX 90 T4 (A6:6)	820	16x22,5°	1000	970	903.5	12
HMX 90 T6 (A6:3)	820	16x22,5°	1000	970	903.5	12
HMX 90 T6 (A6:6)	820	16x22,5°	1000	970	903.5	12
HMX 100 T4 (A6:3)	820	16x22,5°	1115	1070	1013	12
HMX 100 T4 (A6:6)	820	16x22,5°	1115	1070	1013	12

Model	E	O	ØA	ØB	ØD	ØJ
HMX 100 T6 (A6:3)	820	16x22,5º	1115	1070	1013	12
HMX 100 T6 (A6:6)	820	16x22,5º	1115	1070	1013	12
HMX 112 T4 (A6:3)	1000	16x22,5º	1234	1190	1132	12
HMX 112 T4 (A6:6)	1000	16x22,5º	1234	1190	1132	12
HMX 112 T6 (A6:3)	1000	16x22,5º	1234	1190	1132	12
HMX 112 T6 (A6:6)	1000	16x22,5º	1234	1190	1132	12
HMX 125 T4 (A7:4)	1000	20x18º	1365	1320	1263	15
HMX 125 T4 (A7:8)	1000	20x18º	1365	1320	1263	15
HMX 125 T6 (A7:4)	1000	20x18º	1365	1320	1263	15
HMX 125 T6 (A7:8)	1000	20x18º	1365	1320	1263	15

Wiring diagram

DIAGRAM N° 1

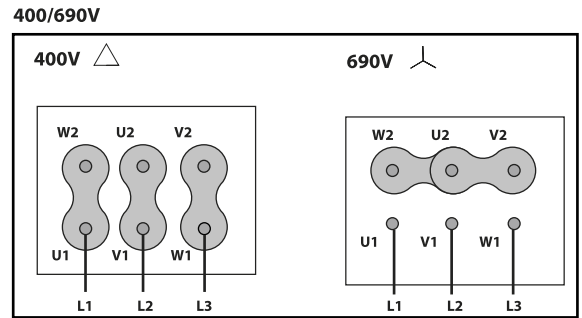
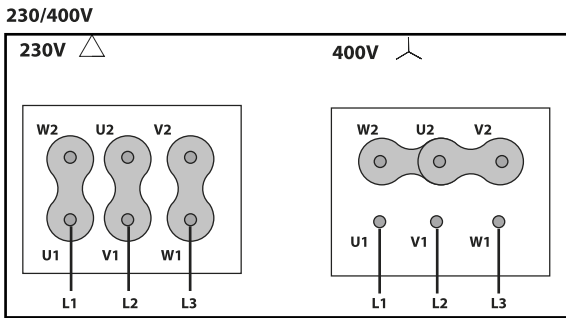

CHARACTERISTIC CURVE

HMX 35 T4 (A0:6)

AIR FLOW - PRESSURE

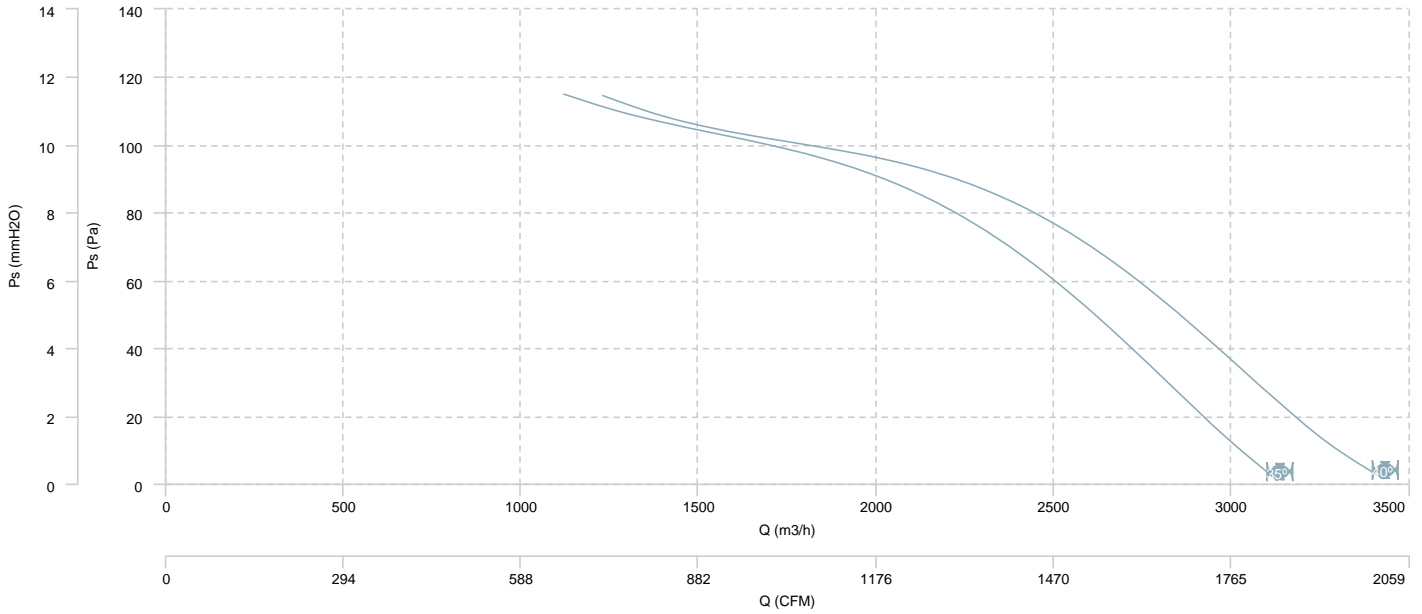

AIR FLOW - MECHANICAL POWER

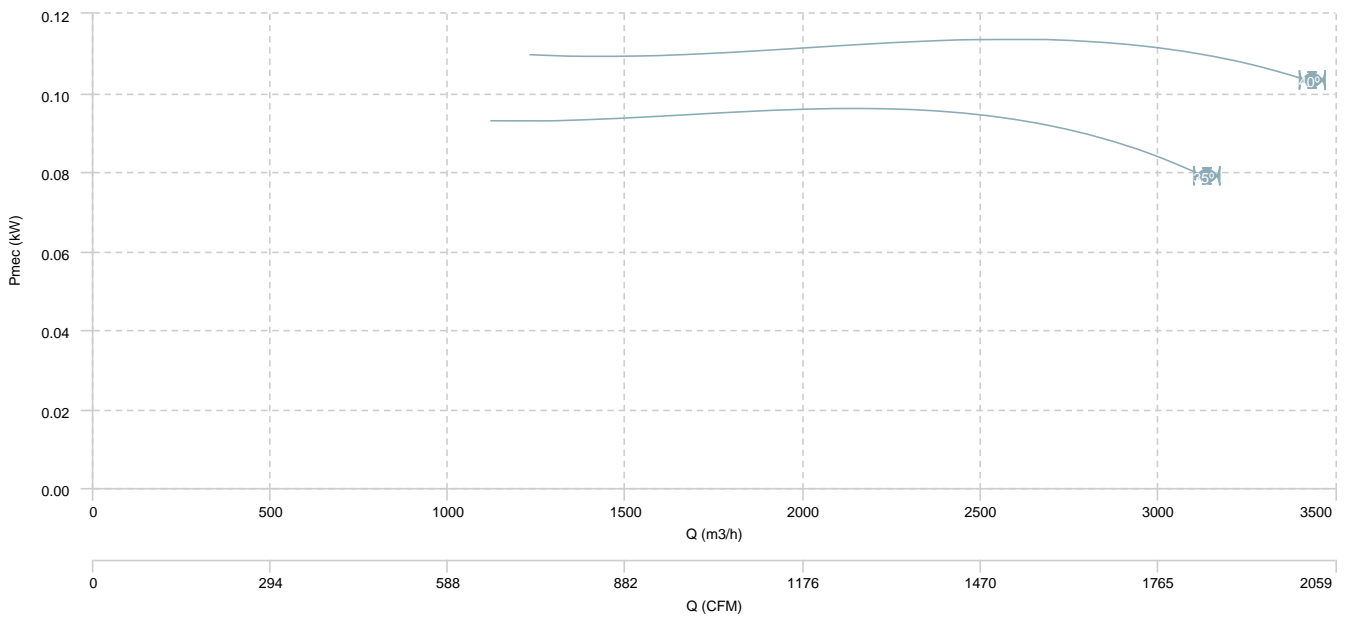

HMX 40 T4 (A0:6)

AIR FLOW - PRESSURE

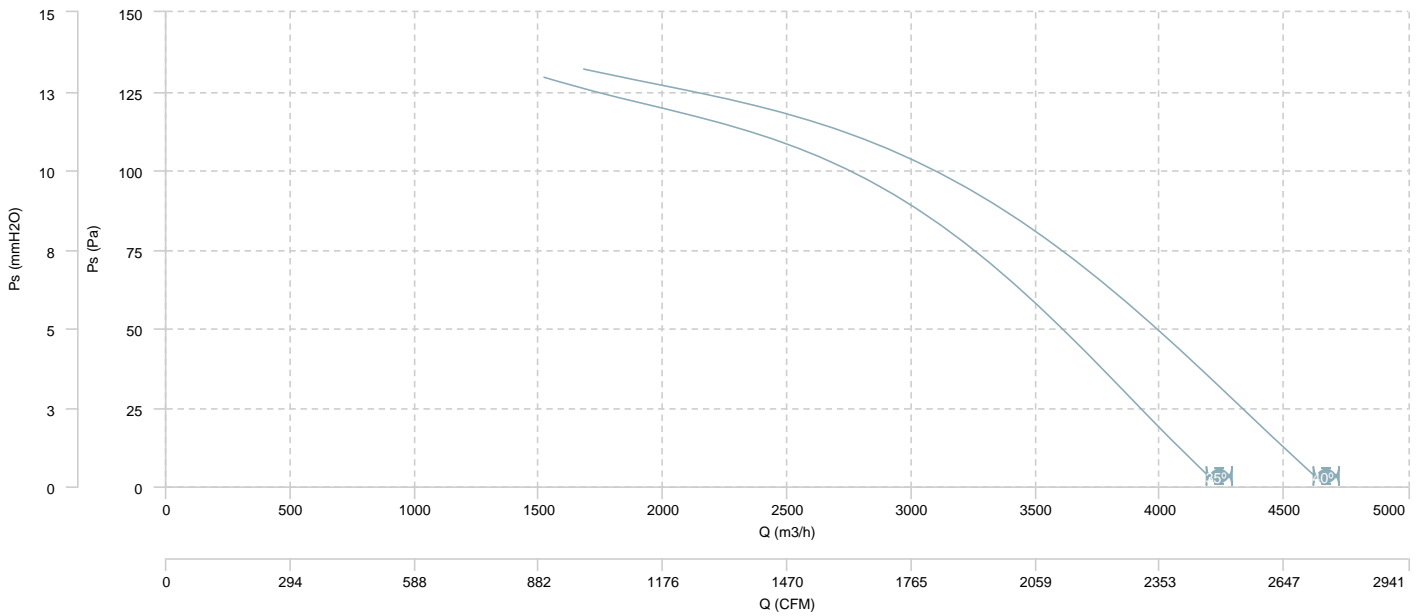

AIR FLOW - MECHANICAL POWER

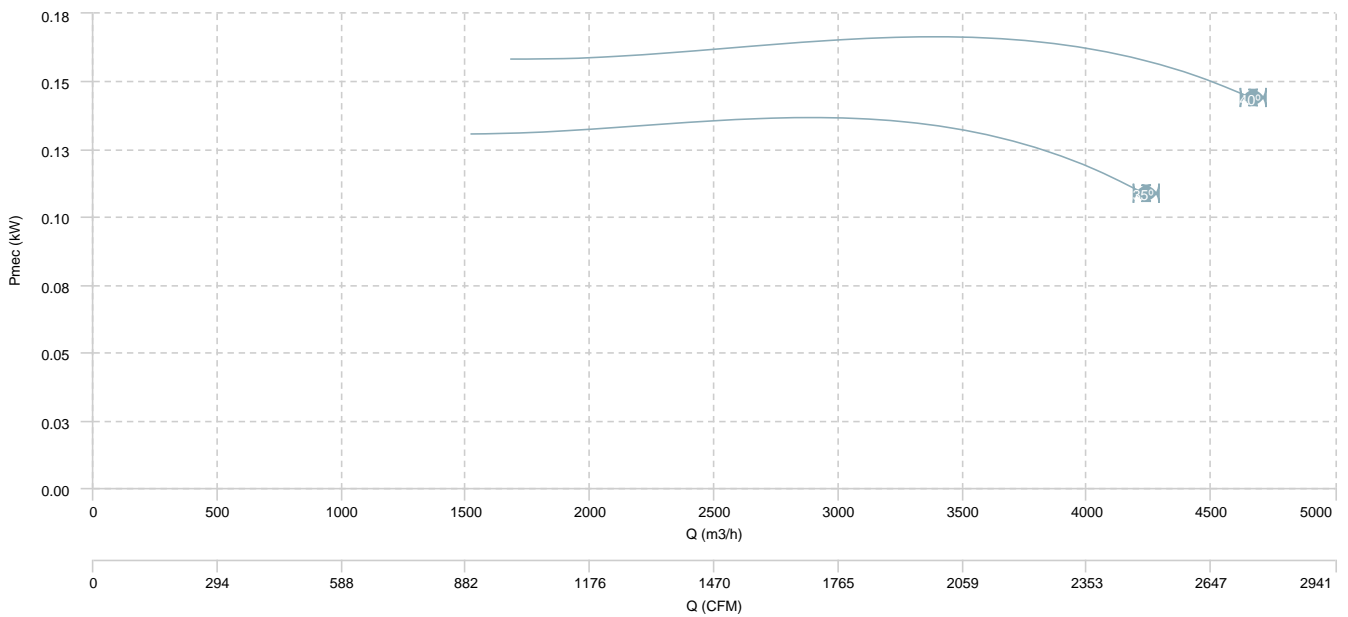

HMX 40 T6 (A0:6)

AIR FLOW - PRESSURE

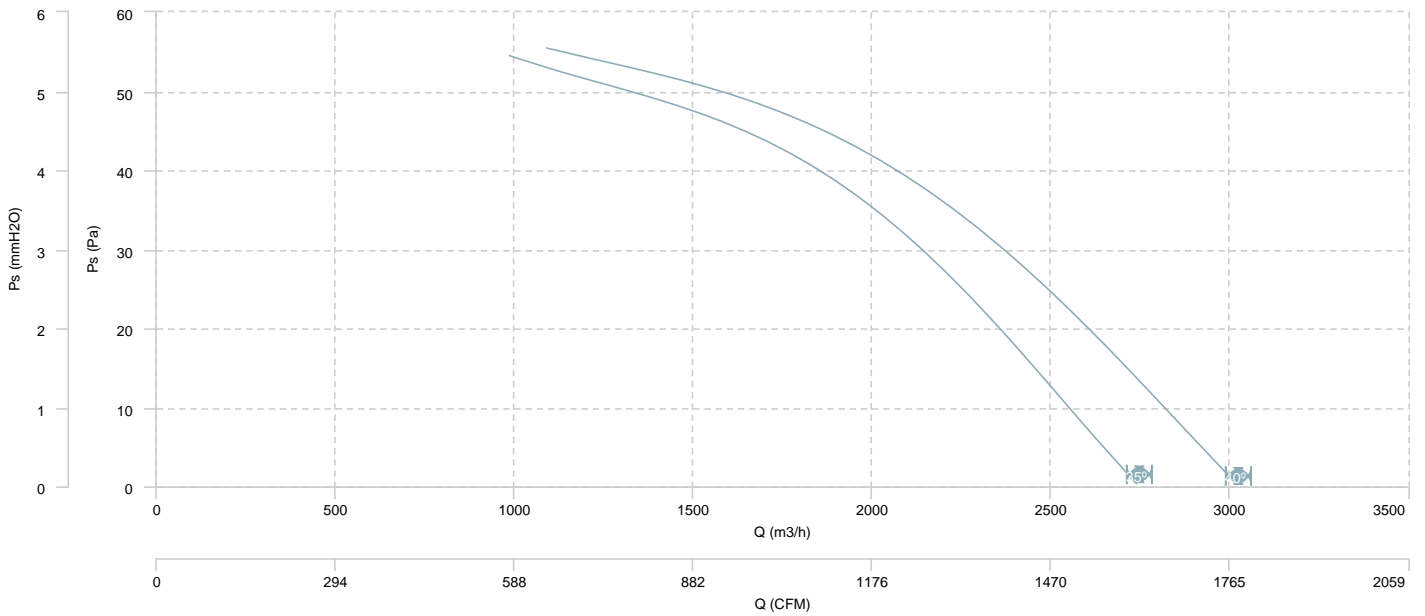

AIR FLOW - MECHANICAL POWER

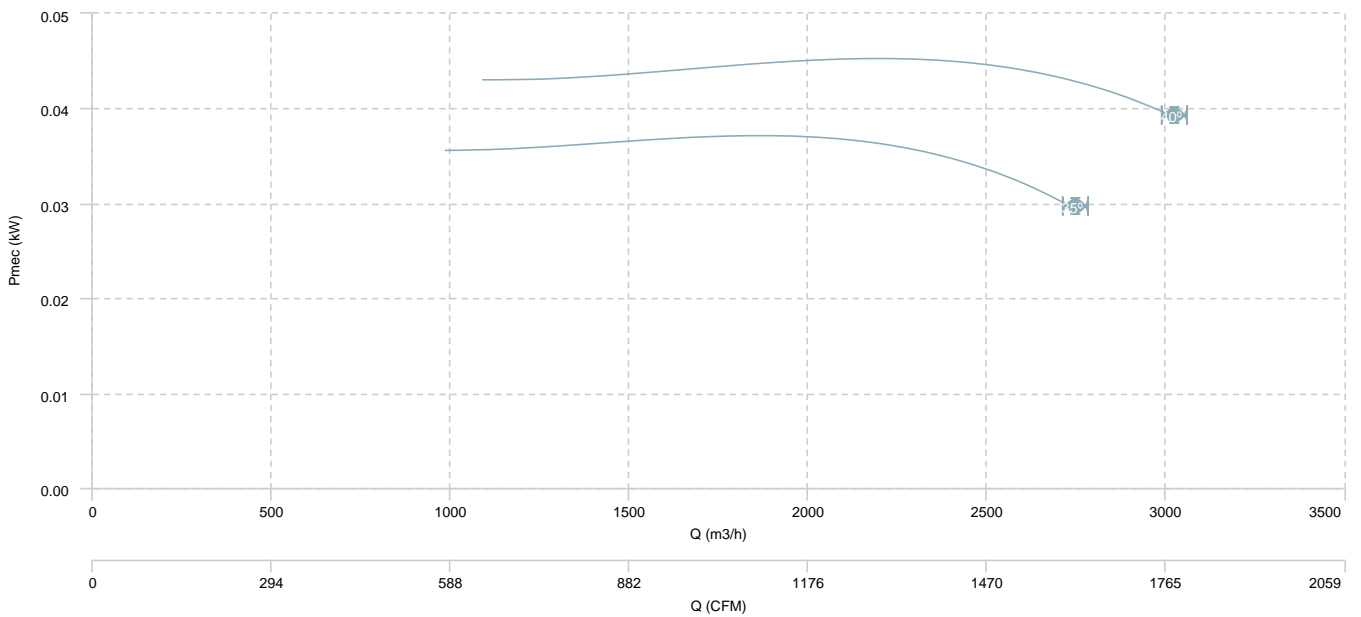

HMX 45 T4 (A0:6)

AIR FLOW - PRESSURE

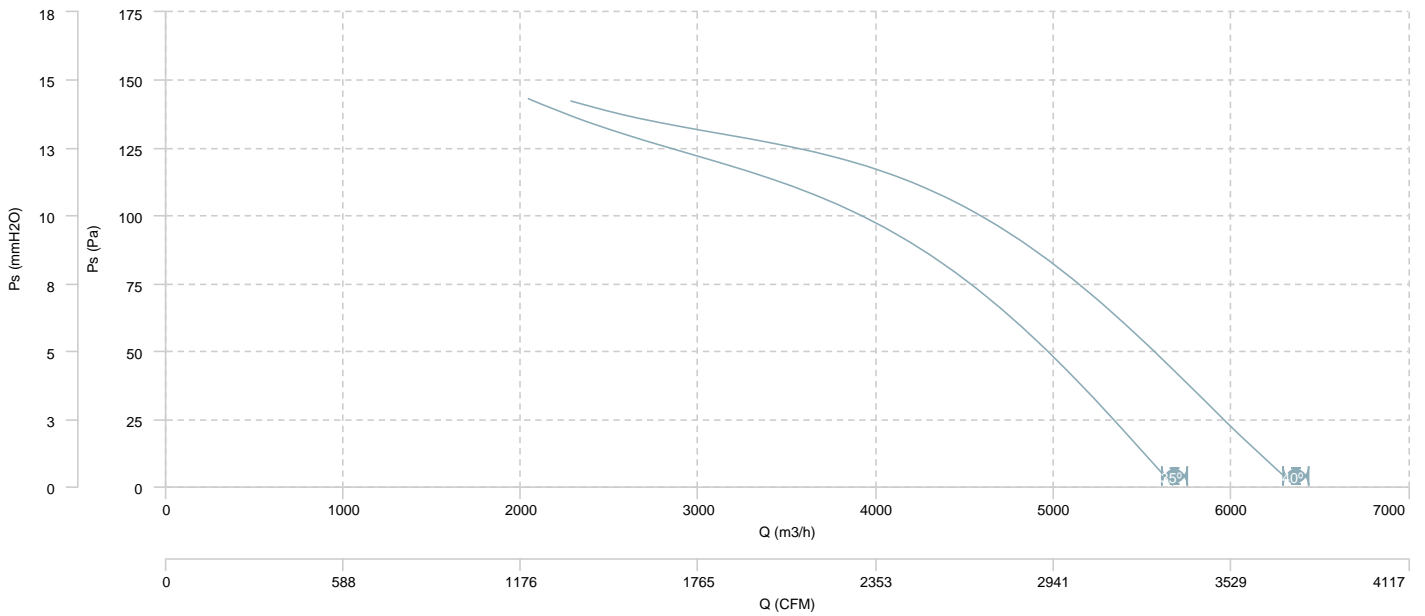

AIR FLOW - MECHANICAL POWER

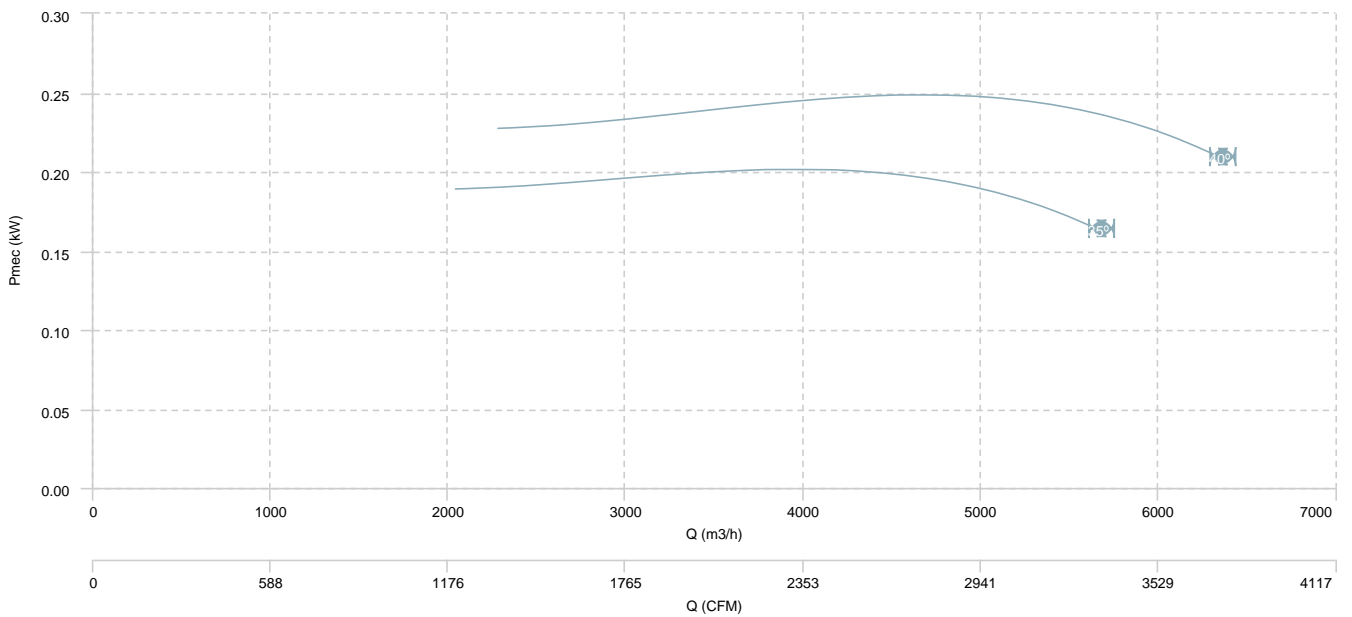

HMX 45 T4 (A5:6)

AIR FLOW - PRESSURE

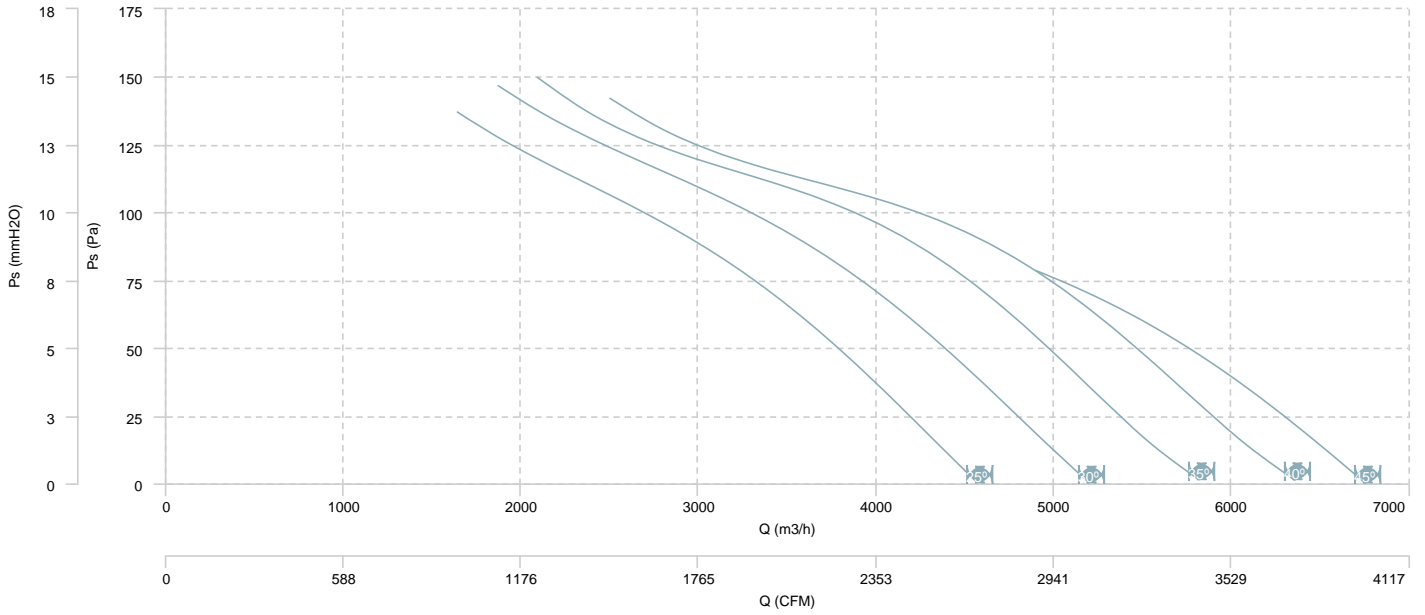

AIR FLOW - MECHANICAL POWER

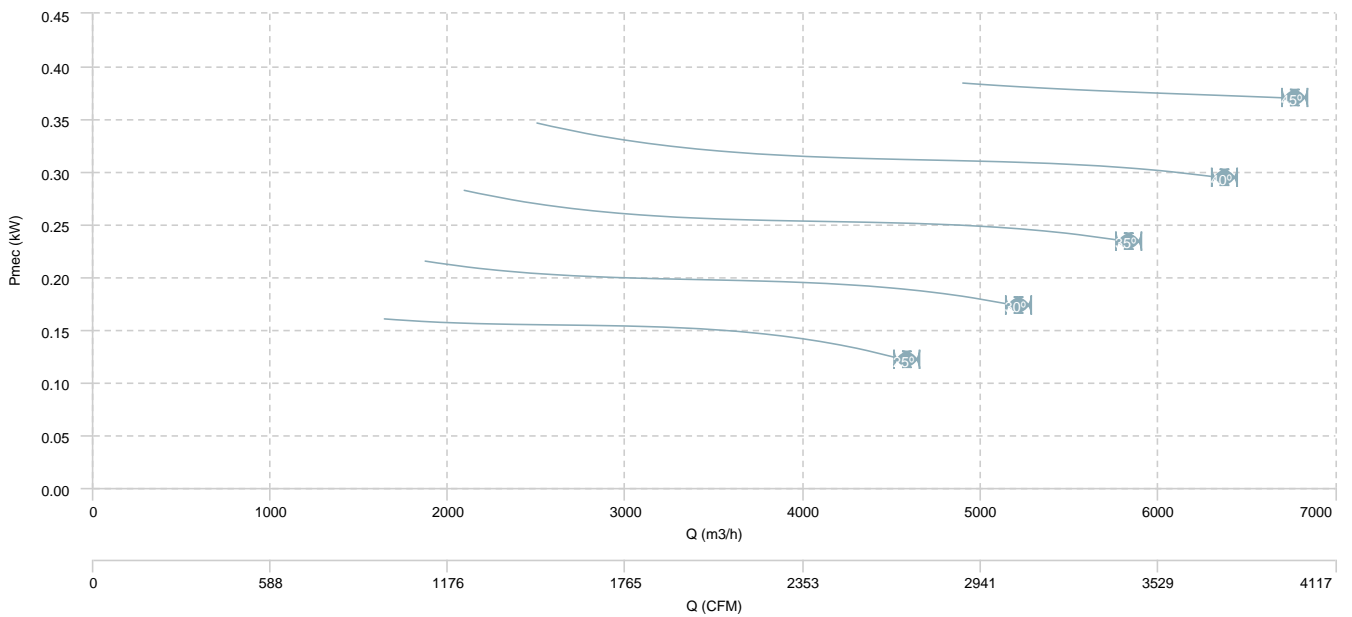

HMX 45 T6 (A0:6)

AIR FLOW - PRESSURE

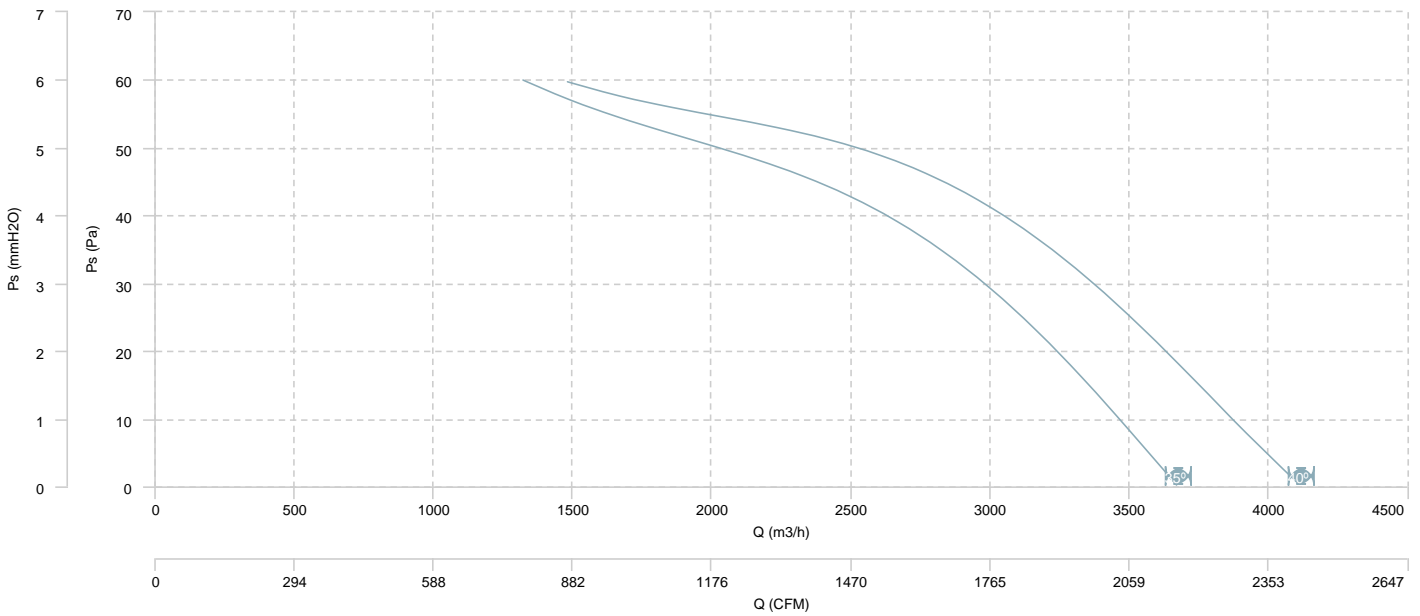

AIR FLOW - MECHANICAL POWER

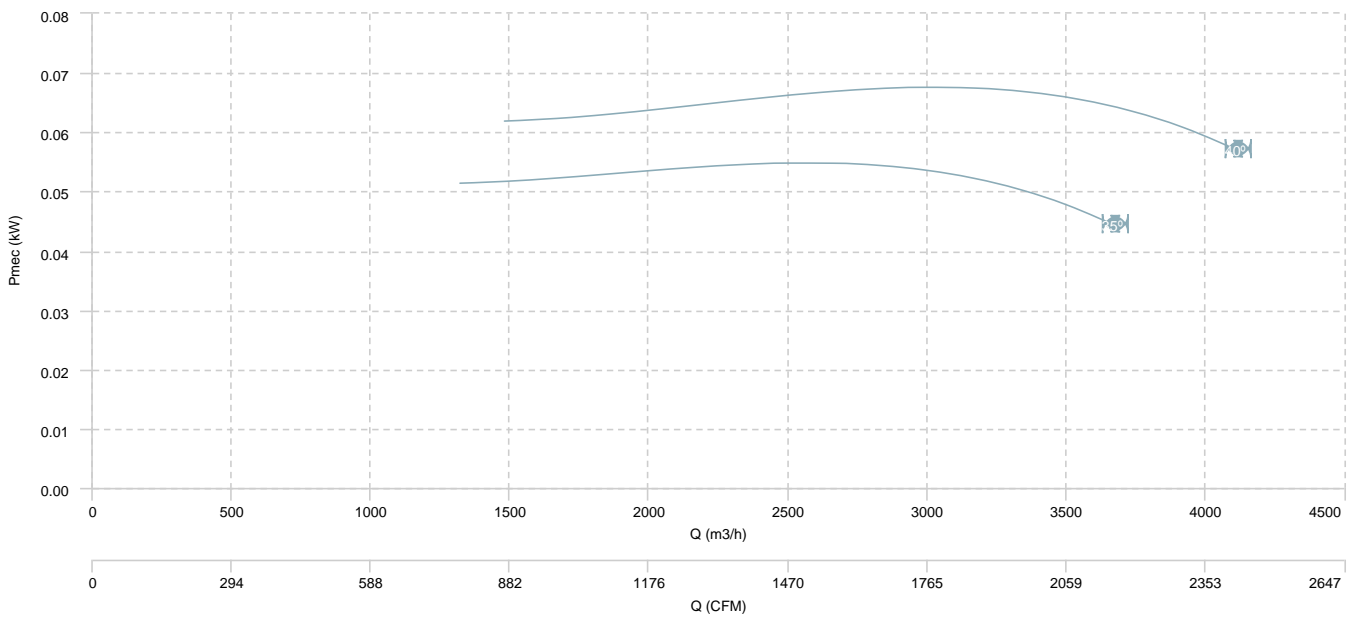

HMX 45 T6 (A5:6)

AIR FLOW - PRESSURE

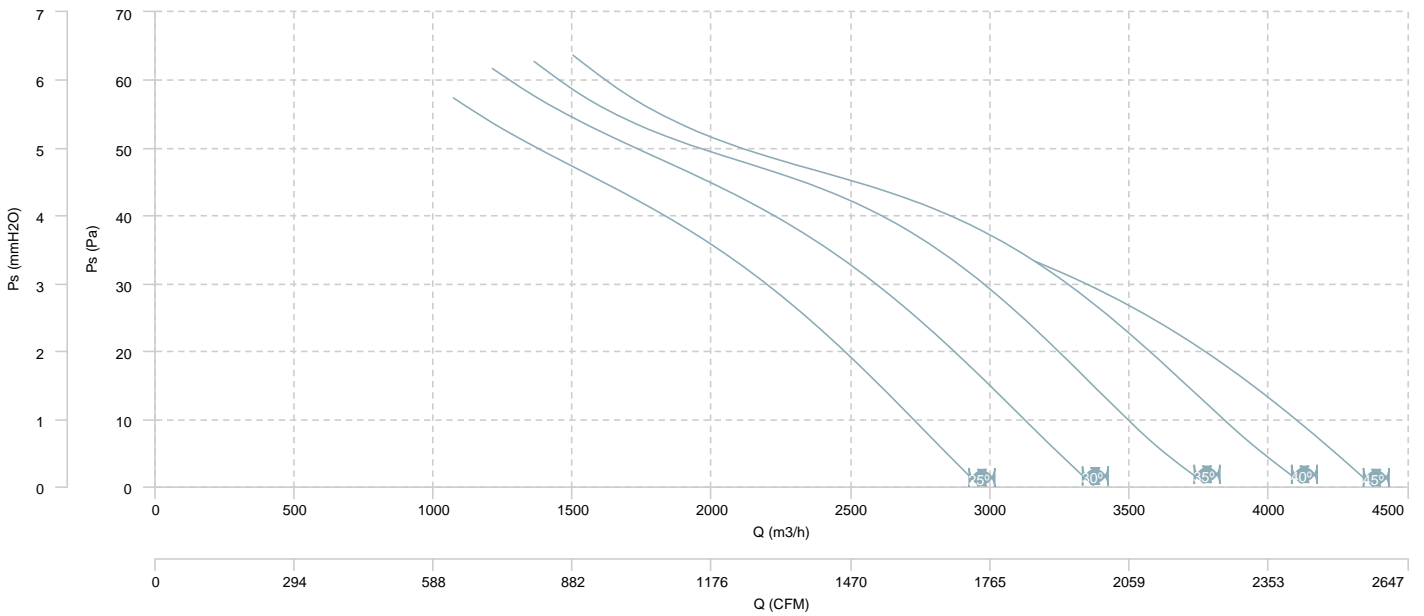

AIR FLOW - MECHANICAL POWER

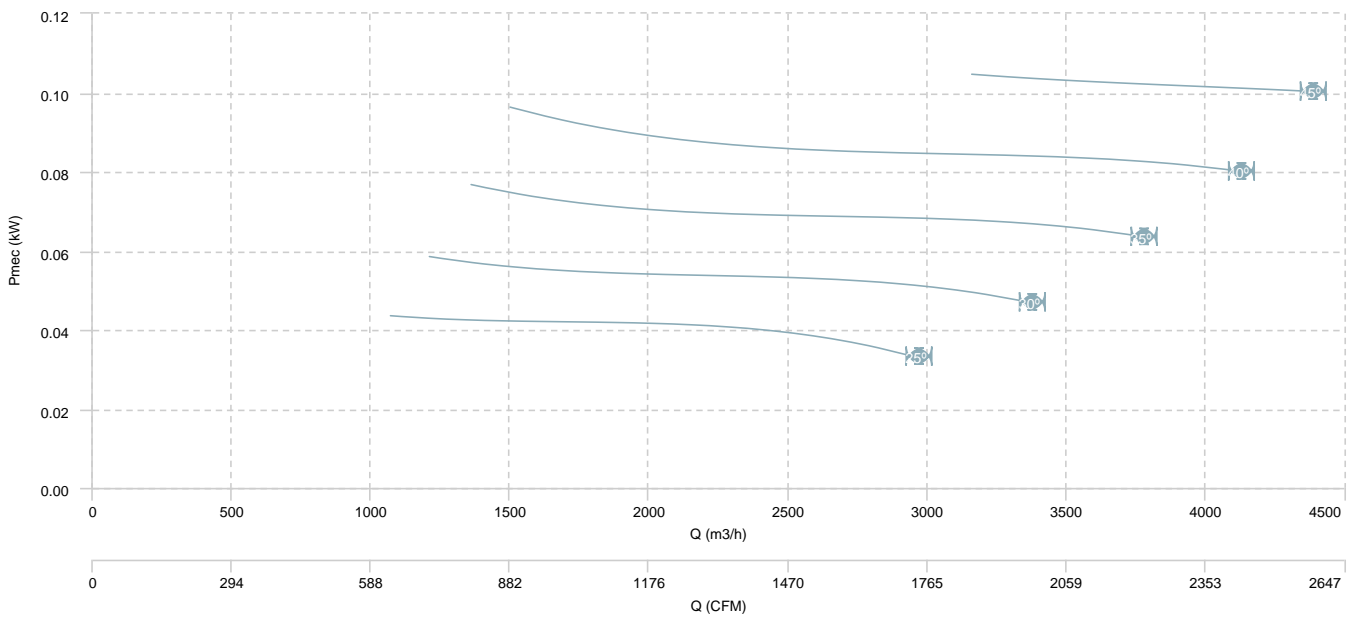

HMX 50 T4 (A5:6)

AIR FLOW - PRESSURE

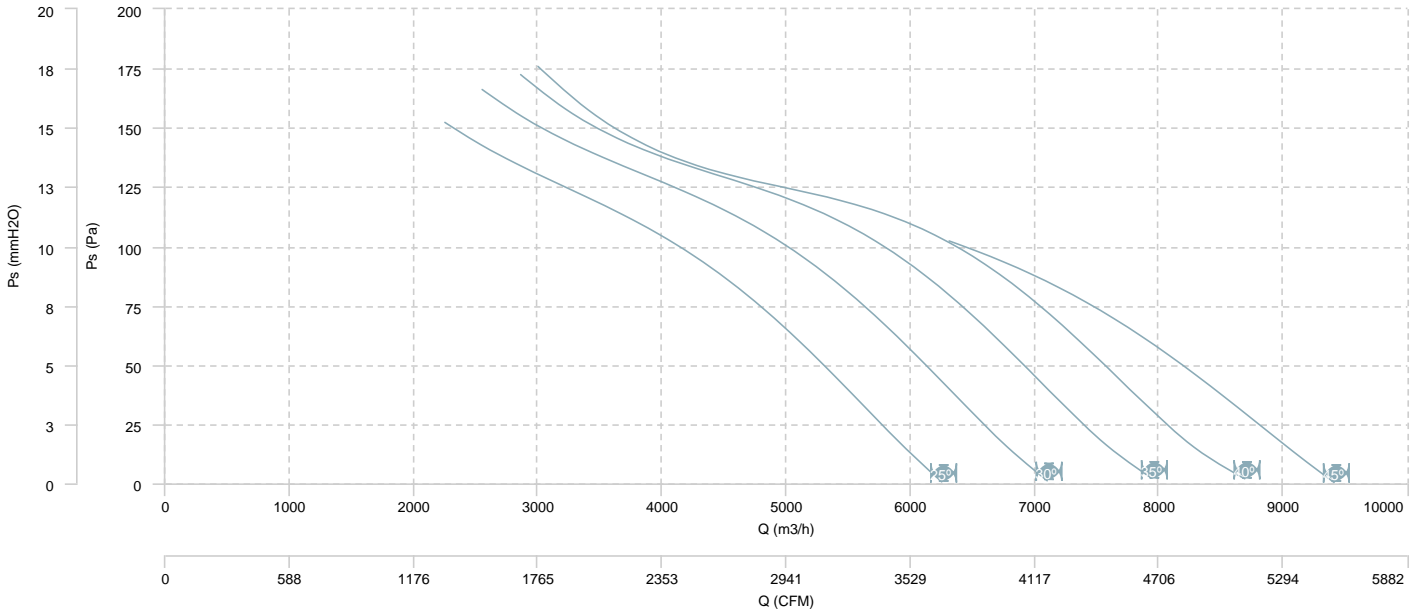

AIR FLOW - MECHANICAL POWER

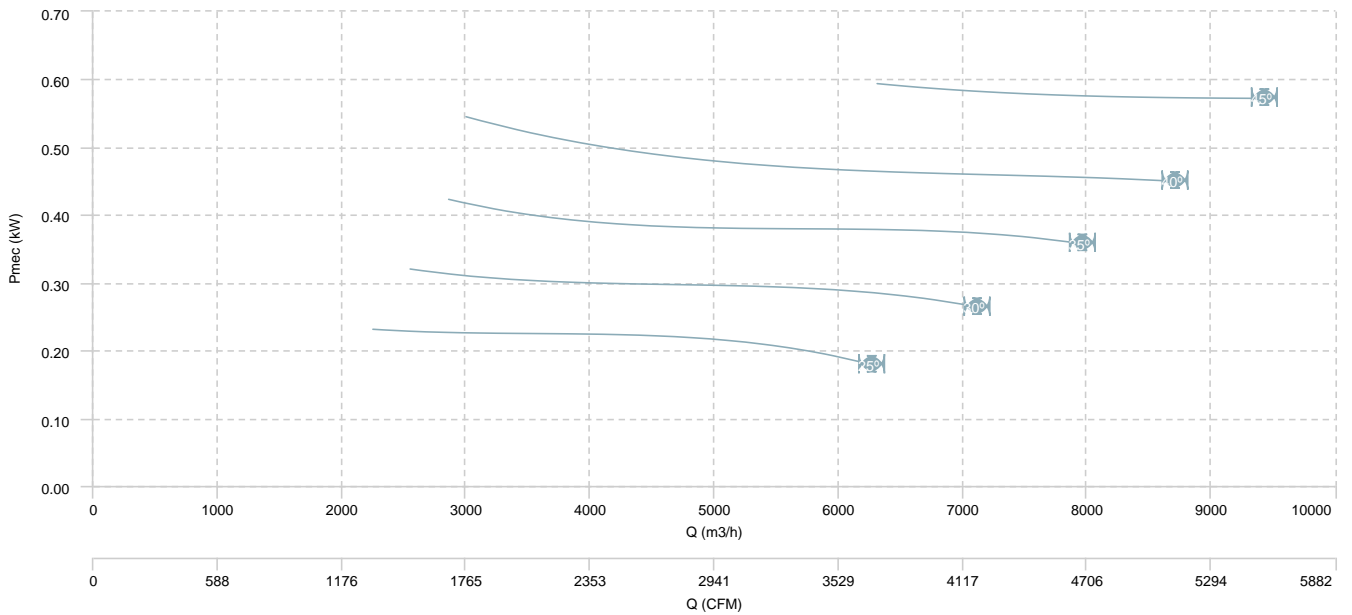

HMX 50 T4 (A0:6)

AIR FLOW - PRESSURE

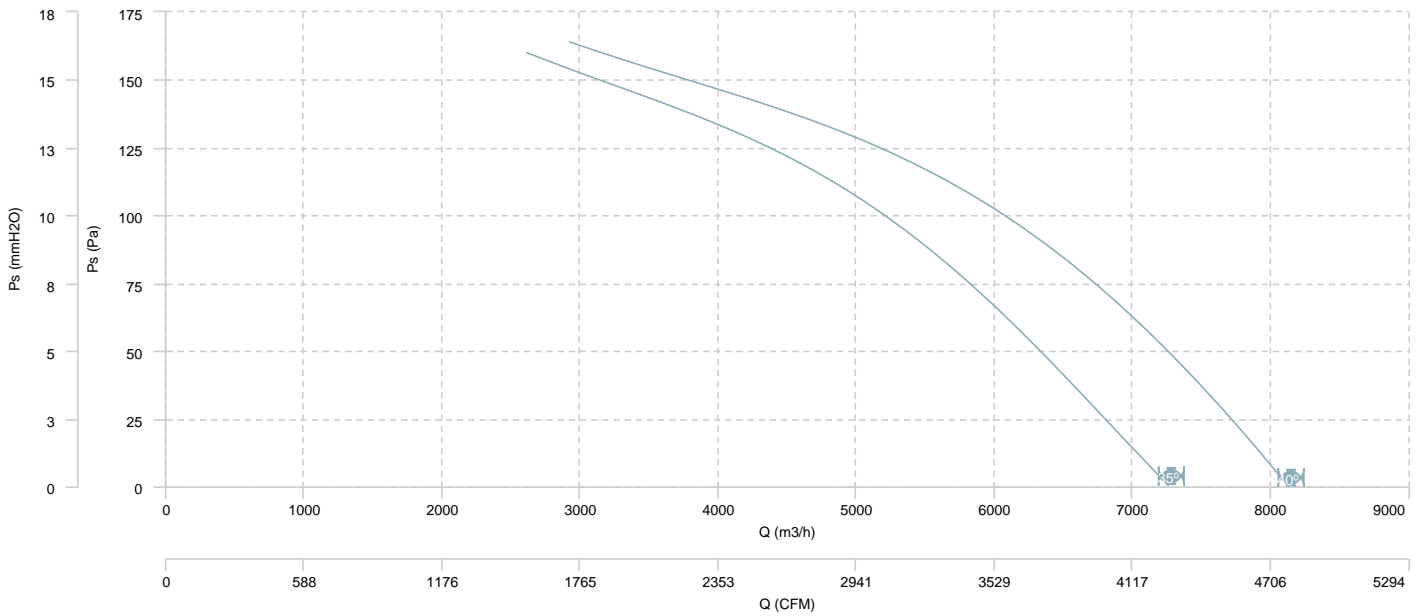

AIR FLOW - MECHANICAL POWER

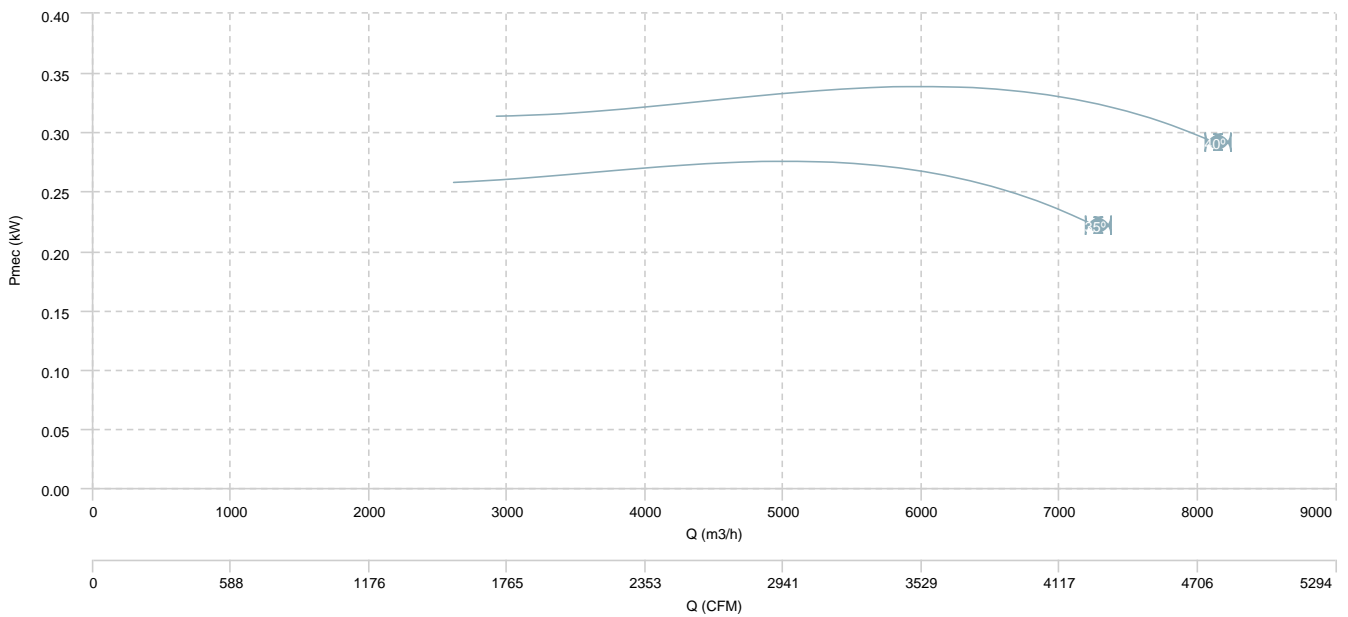

HMX 50 T6 (A0:6)

AIR FLOW - PRESSURE

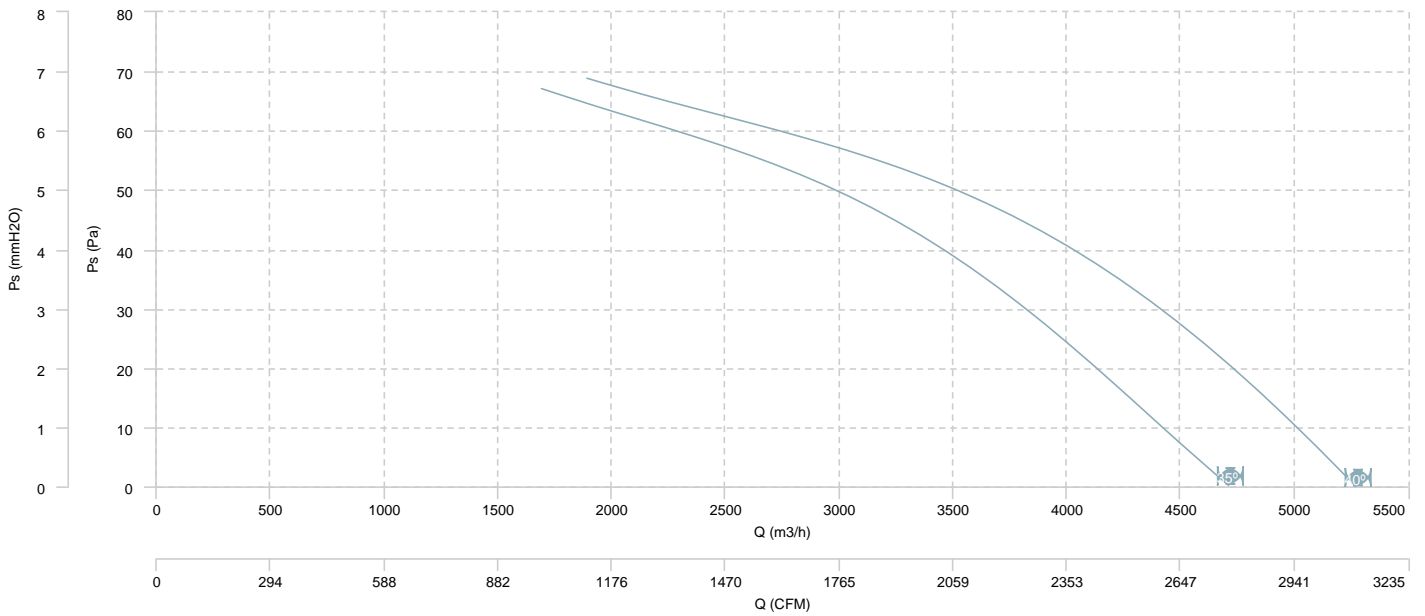

AIR FLOW - MECHANICAL POWER

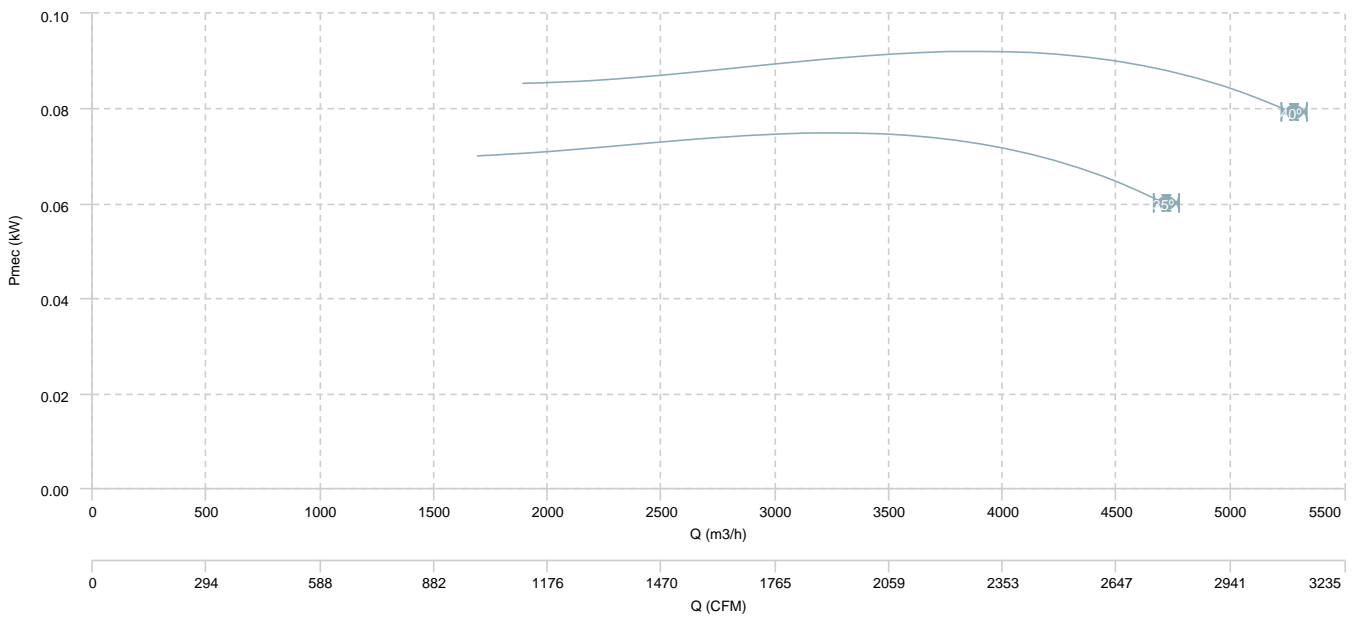

HMX 50 T6 (A5:6)

AIR FLOW - PRESSURE

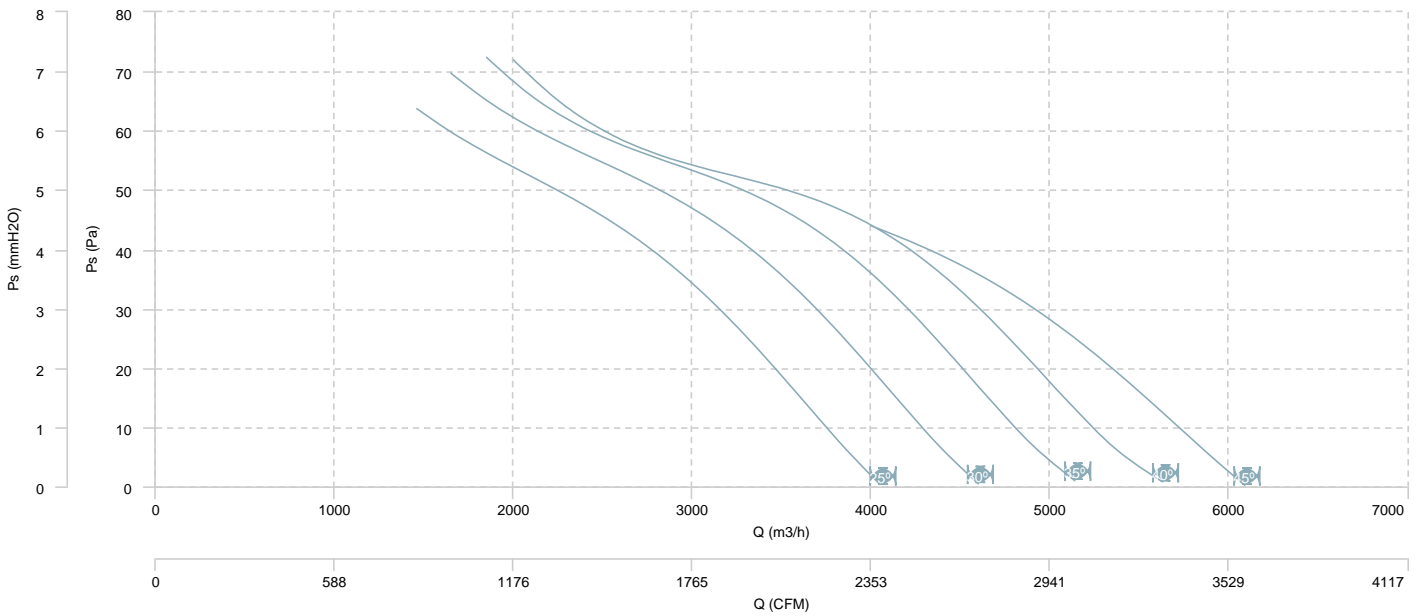

AIR FLOW - MECHANICAL POWER

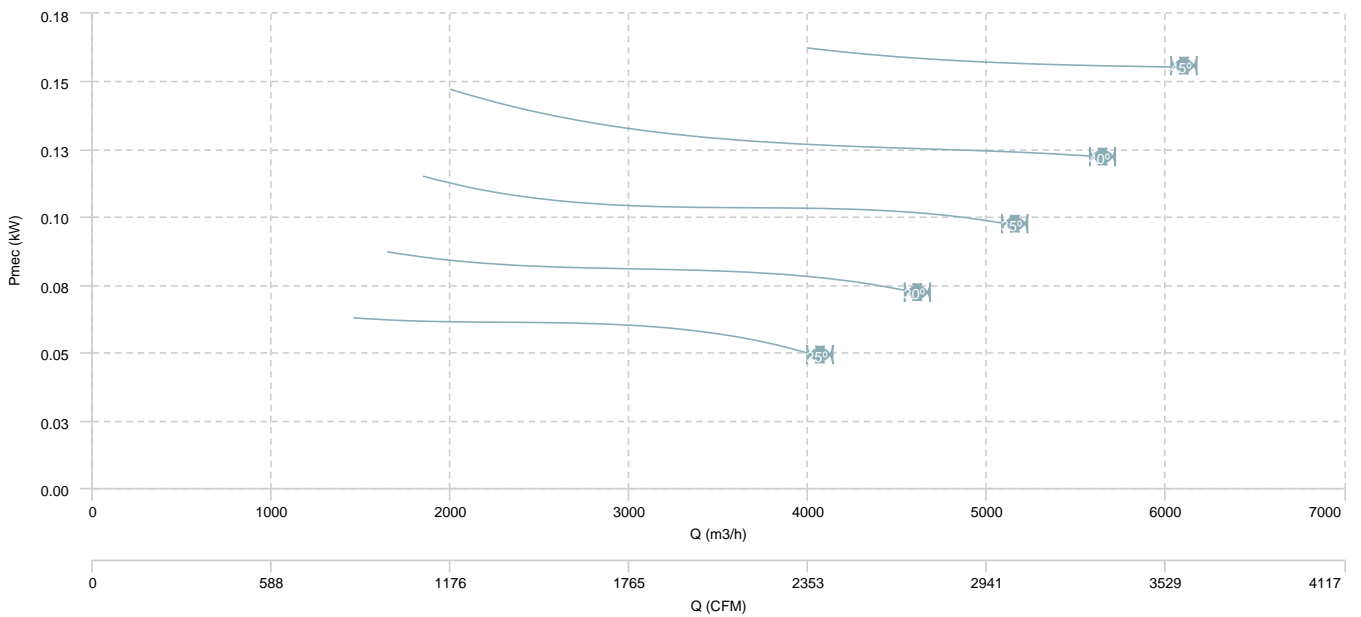

HMX 56 T4 (A5:6)

AIR FLOW - PRESSURE

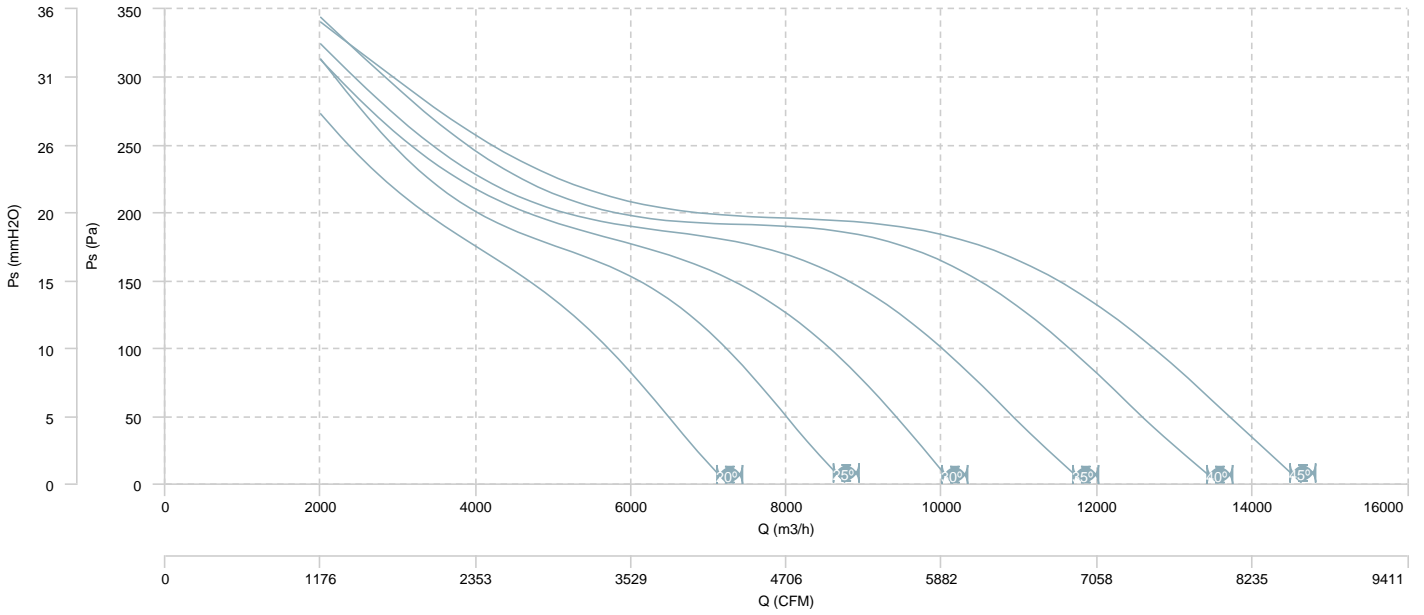

AIR FLOW - MECHANICAL POWER

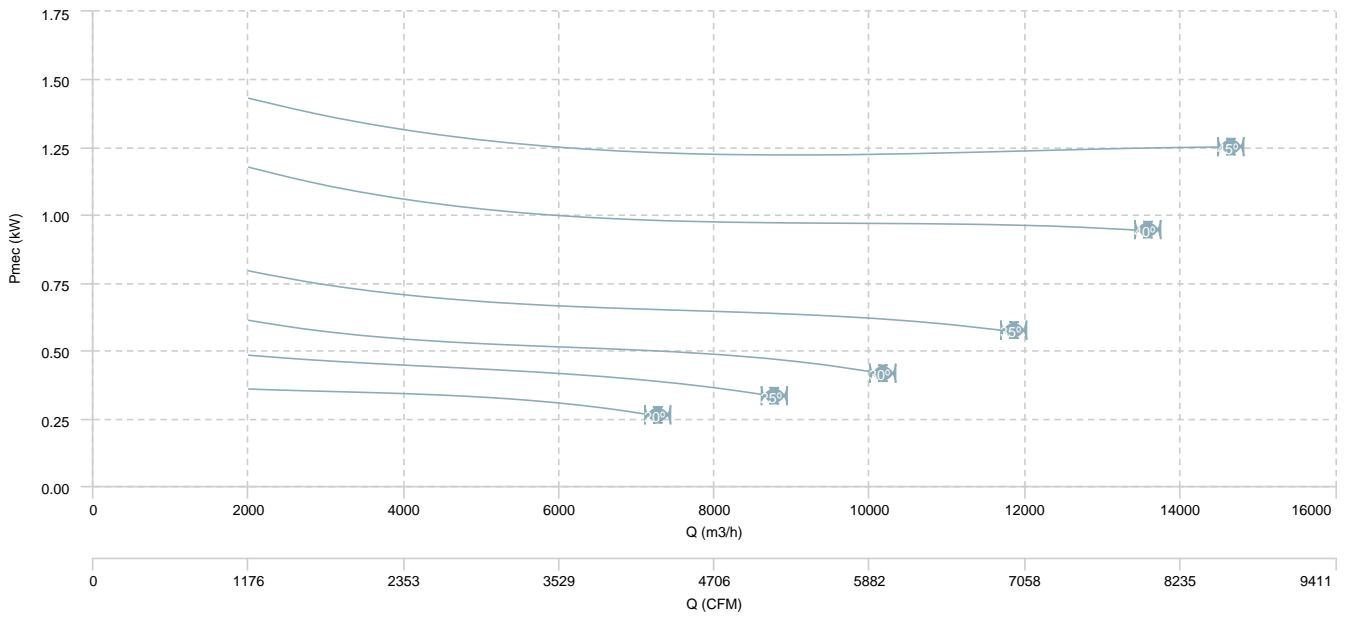

HMX 56 T6 (A5:6)

AIR FLOW - PRESSURE

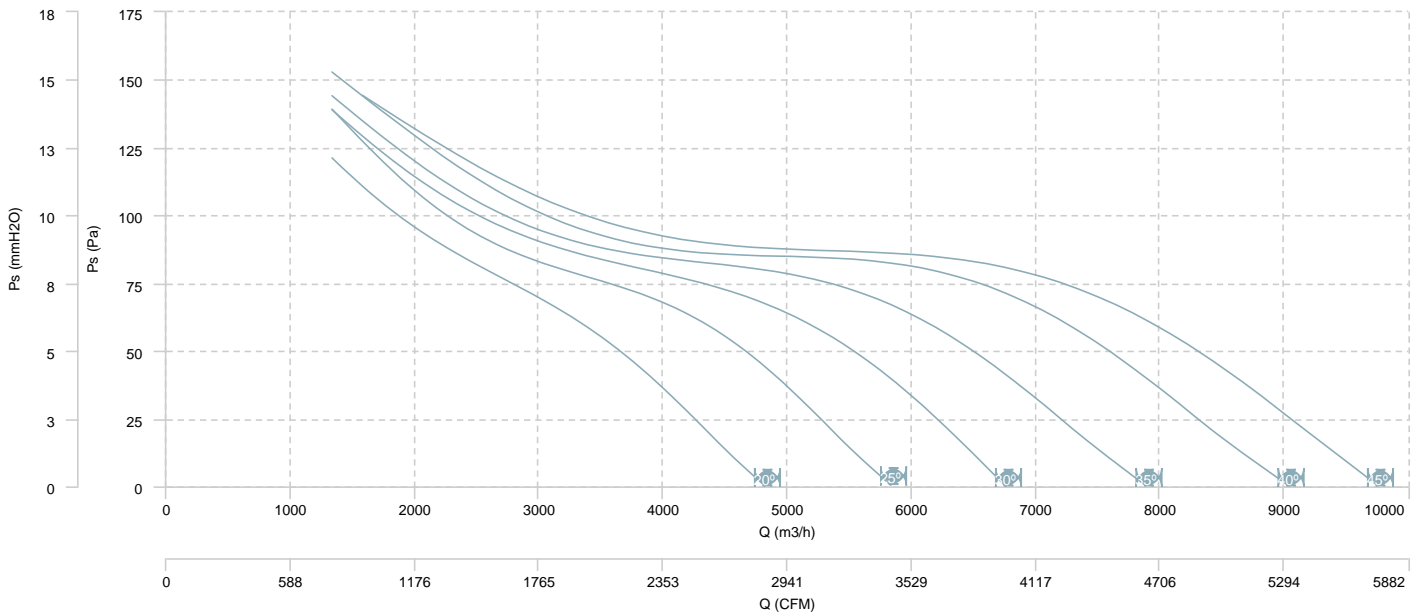

AIR FLOW - MECHANICAL POWER

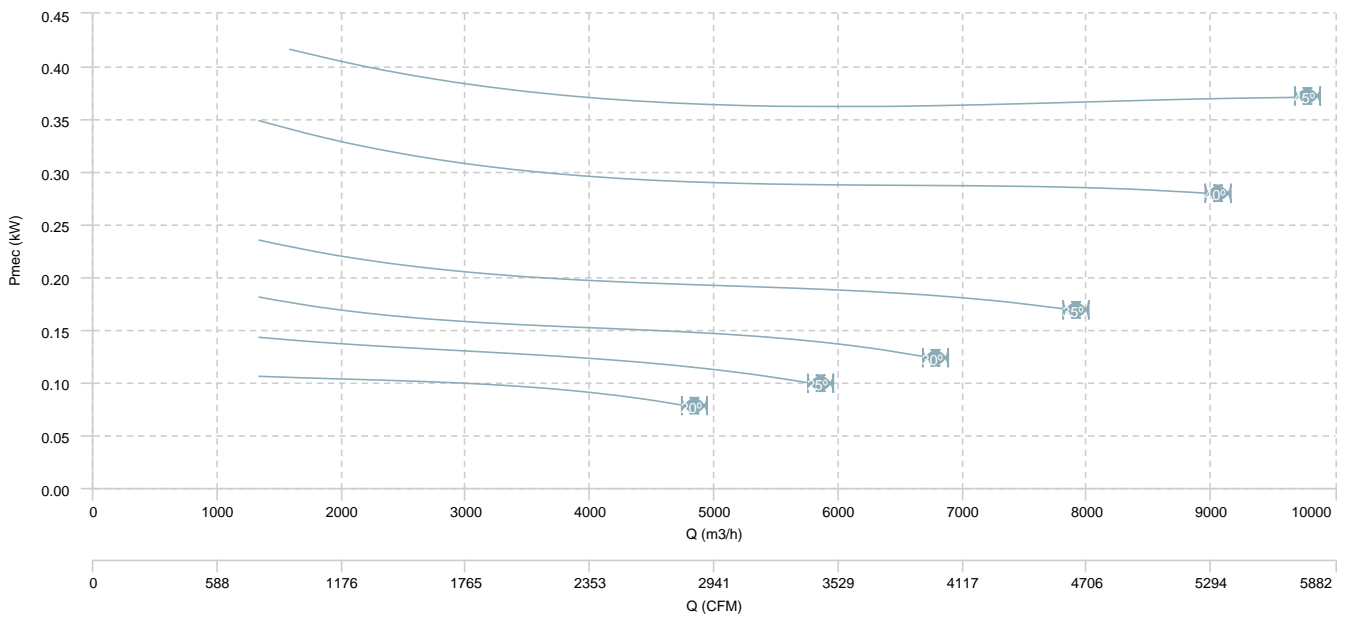

HMX 63 T4 (A5:6)

AIR FLOW - PRESSURE

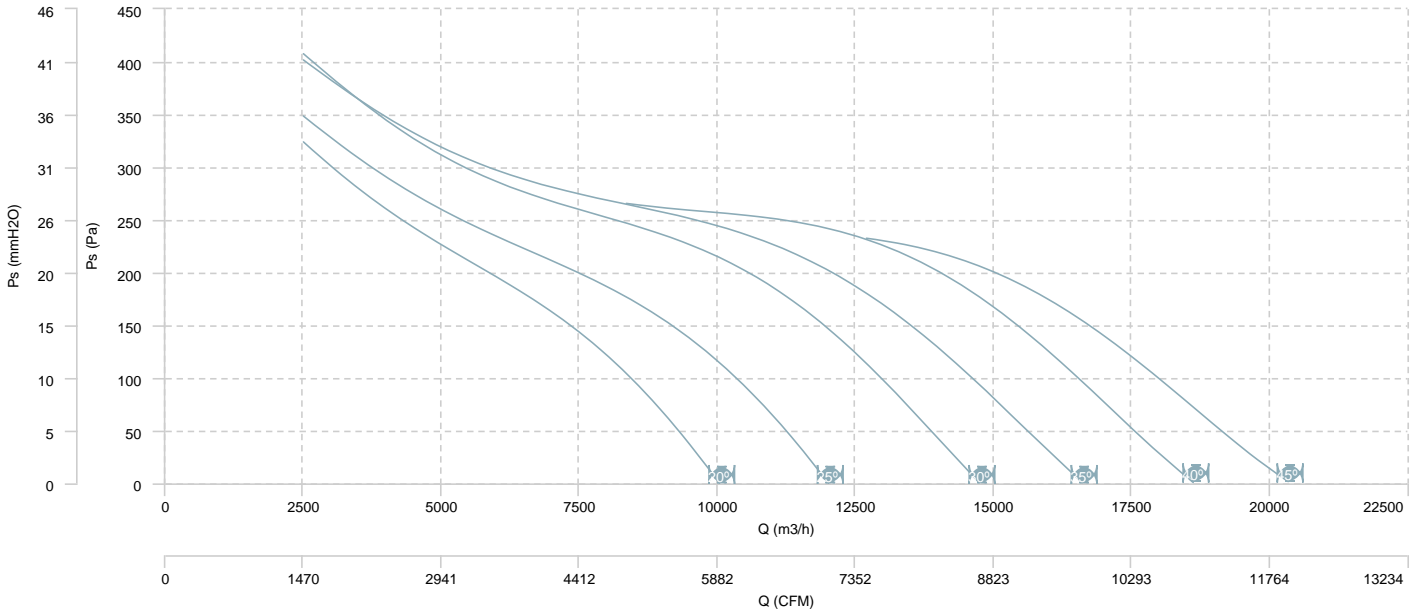

AIR FLOW - MECHANICAL POWER

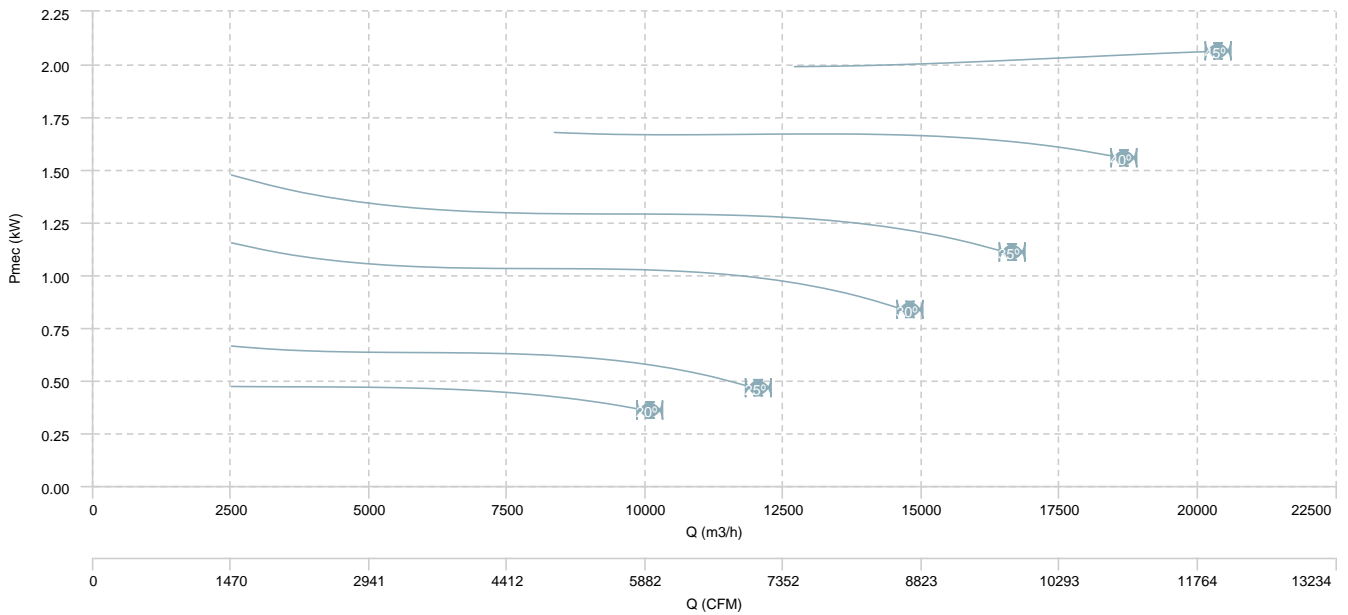

HMX 63 T6 (A5:6)

AIR FLOW - PRESSURE

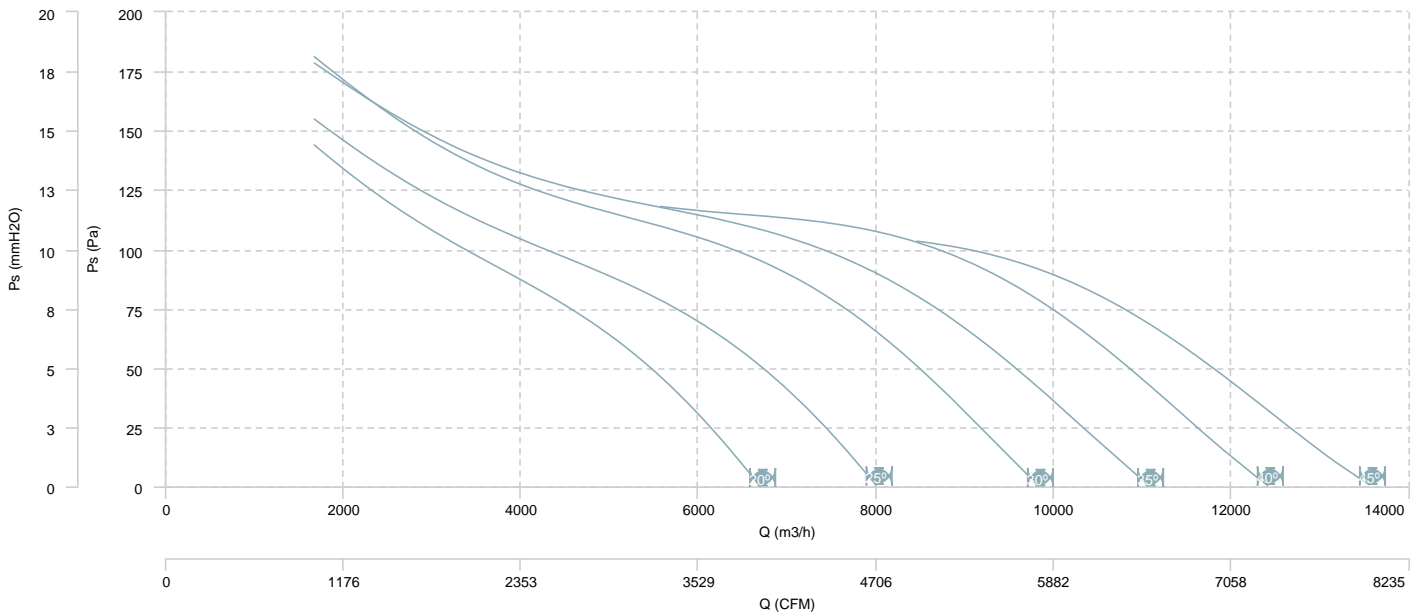

AIR FLOW - MECHANICAL POWER

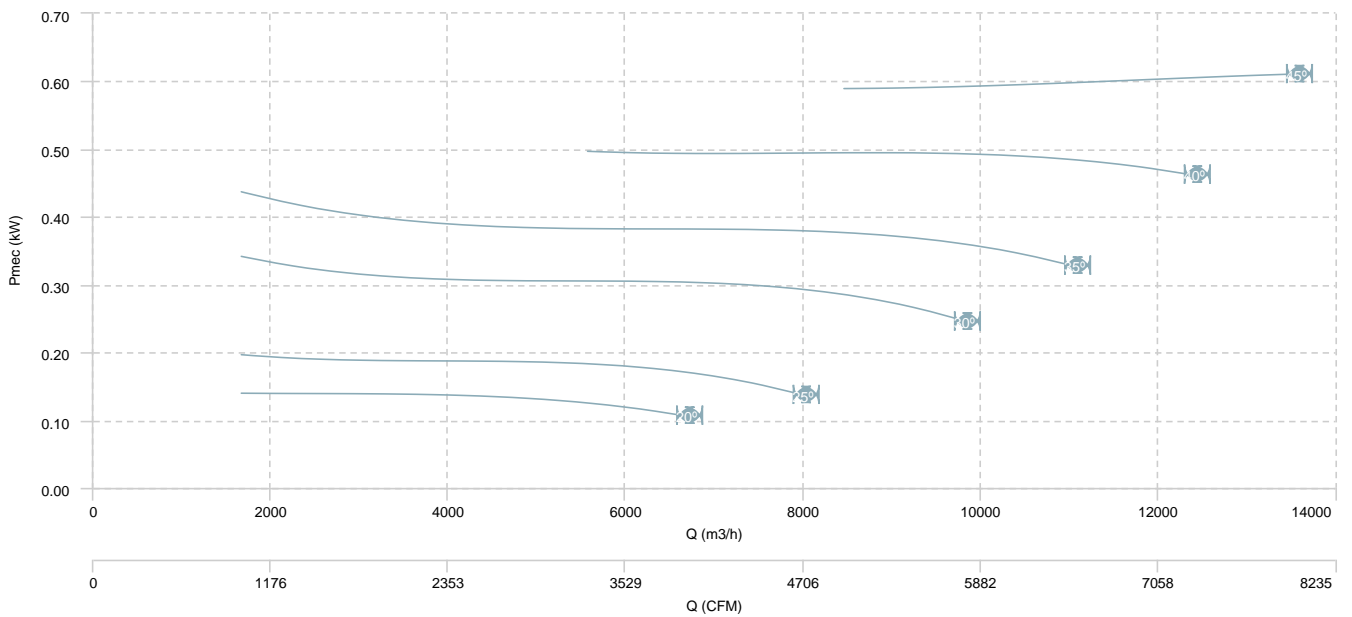

HMX 71 T4 (A5:6)

AIR FLOW - PRESSURE

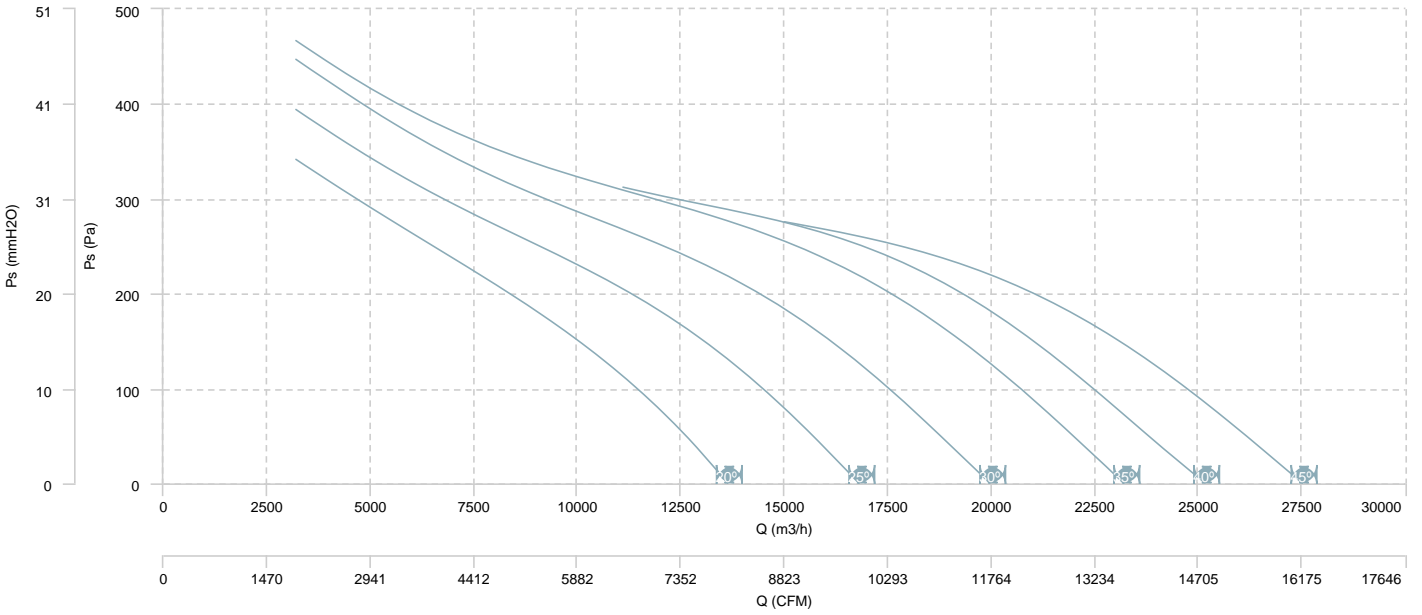

AIR FLOW - MECHANICAL POWER

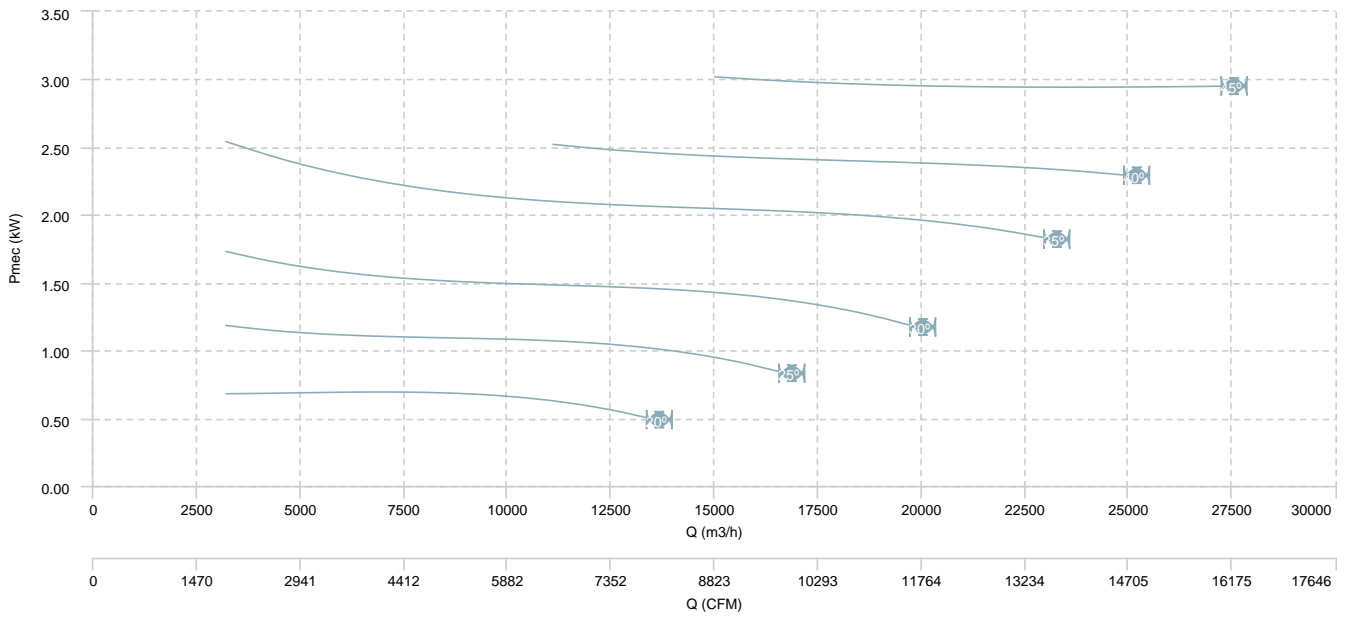

HMX 71 T6 (A5:6)

AIR FLOW - PRESSURE

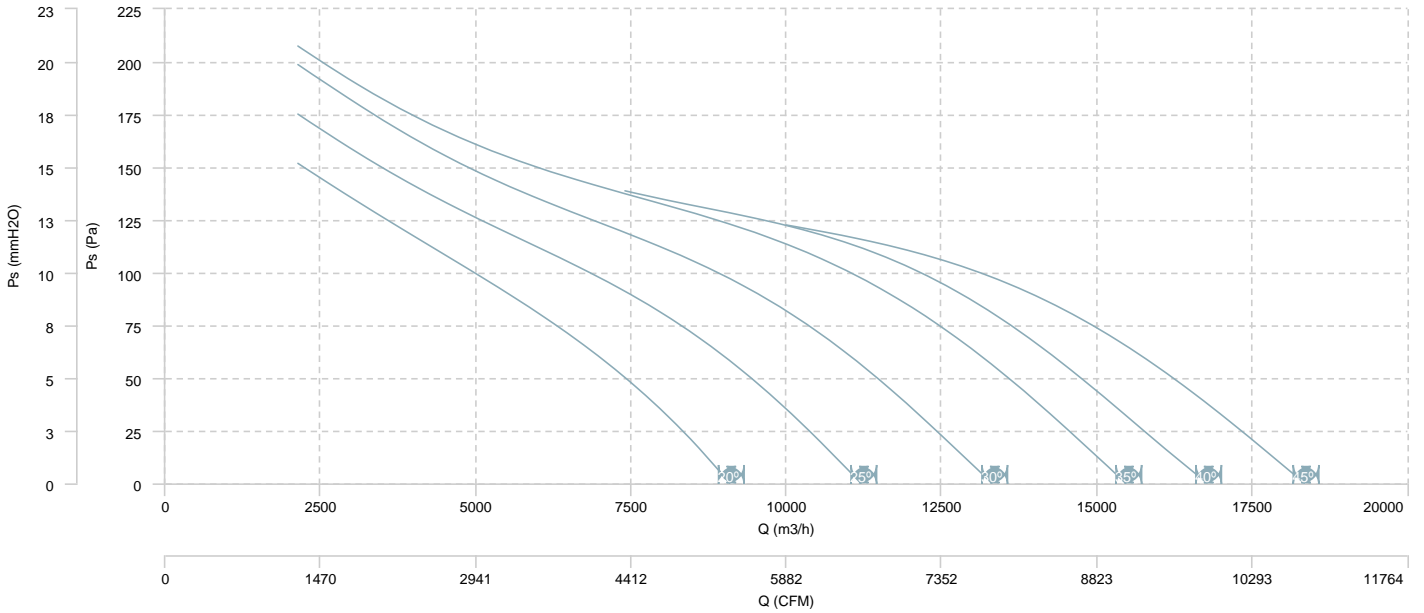

AIR FLOW - MECHANICAL POWER

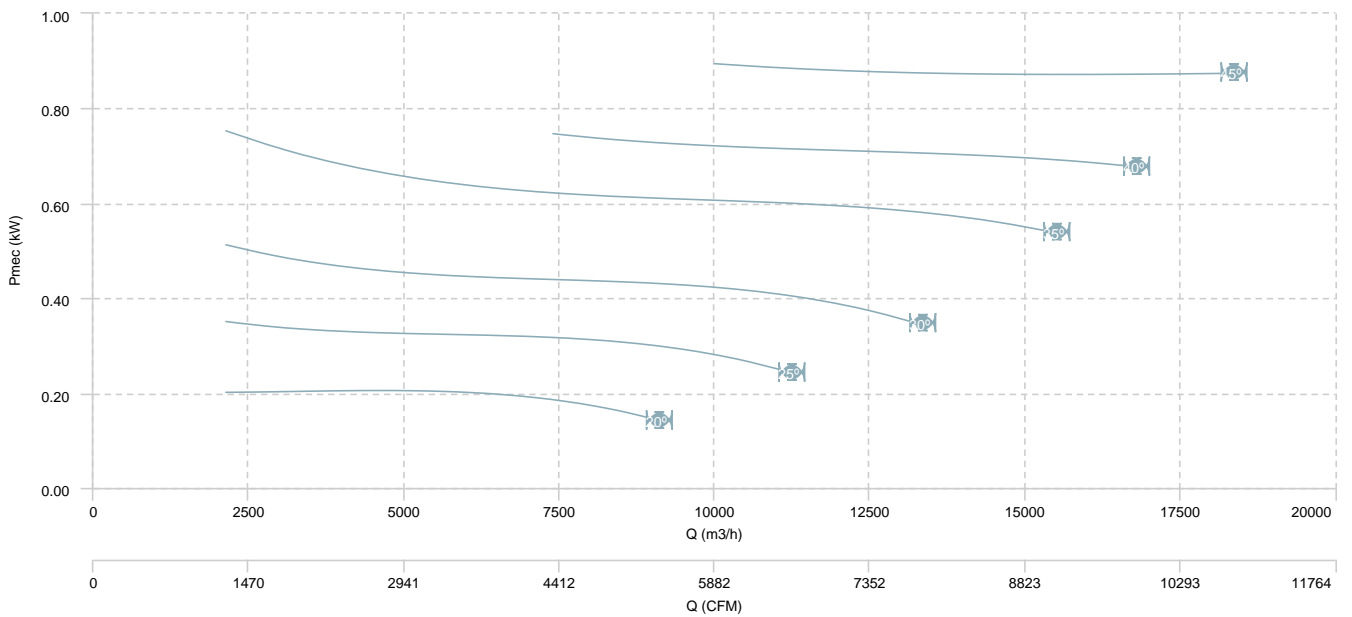

HMX 80 T4 (A5:6)

AIR FLOW - PRESSURE

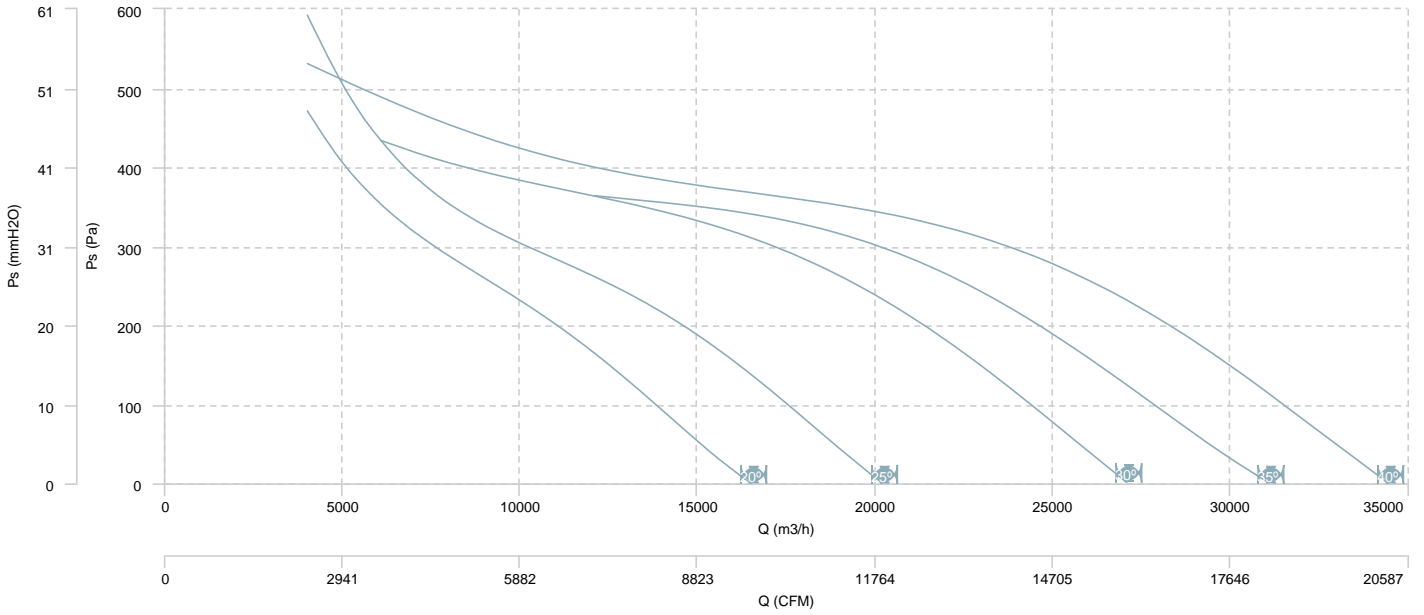

AIR FLOW - MECHANICAL POWER

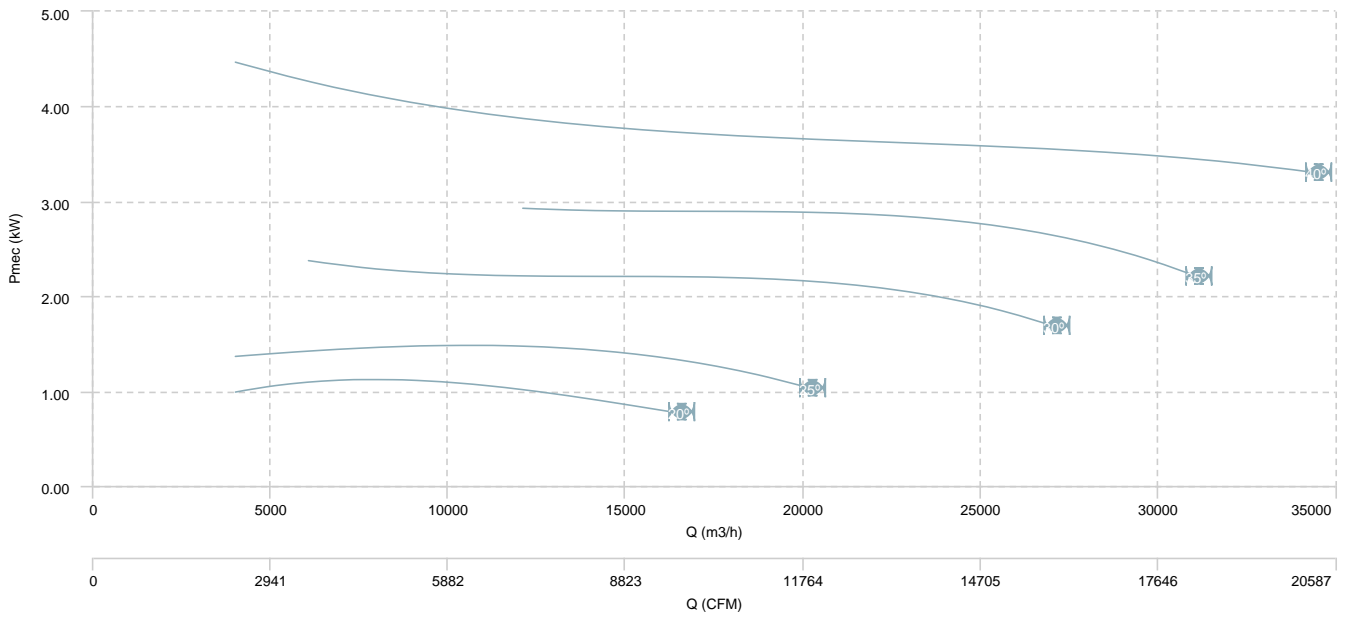

HMX 80 T6 (A5:6)

AIR FLOW - PRESSURE

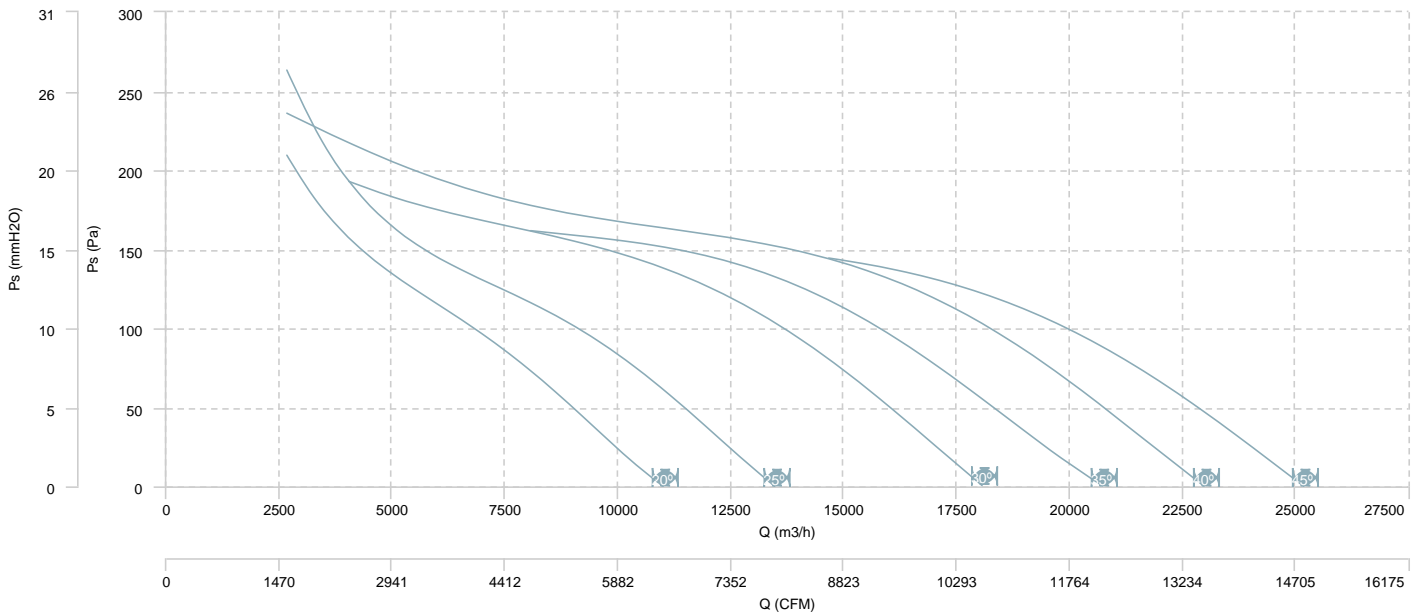

AIR FLOW - MECHANICAL POWER

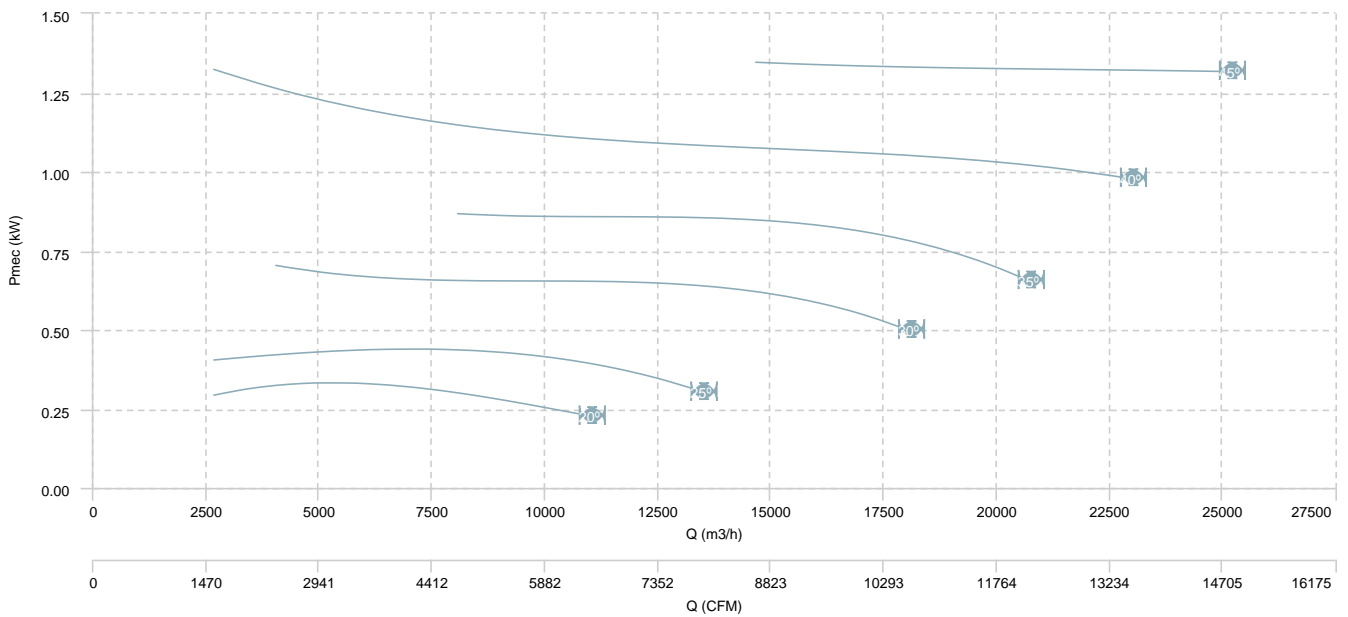

HMX 90 T4 (A6:3)

AIR FLOW - PRESSURE

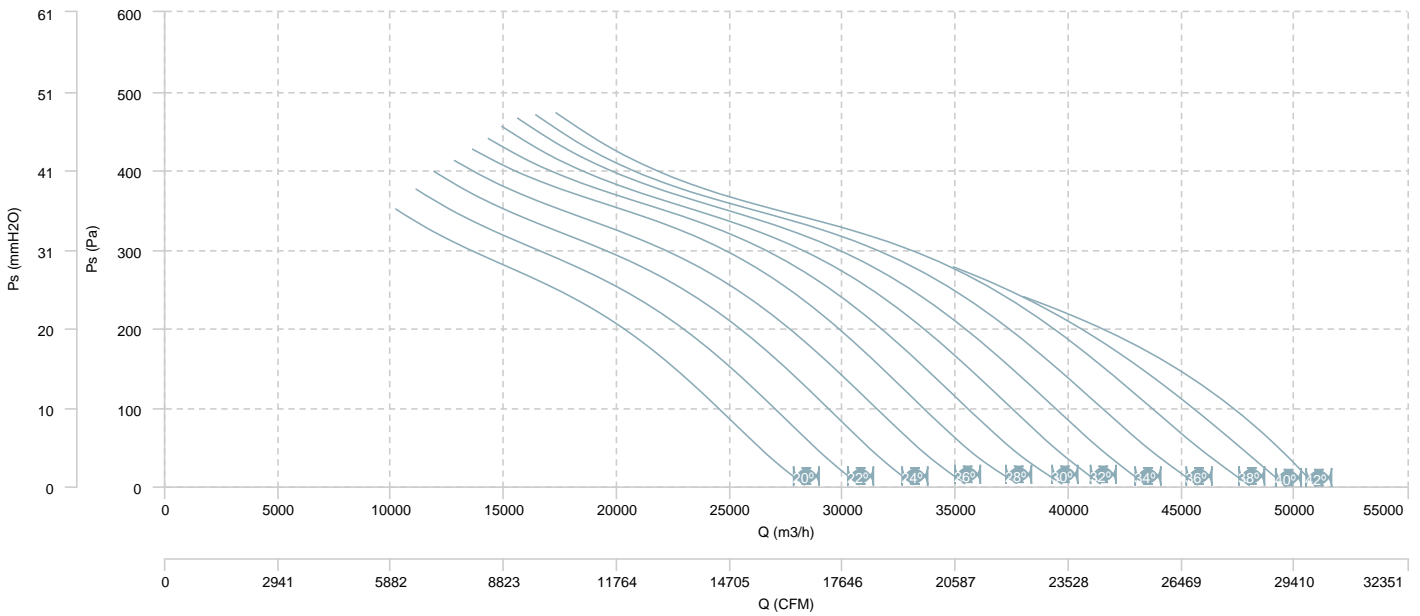

AIR FLOW - MECHANICAL POWER

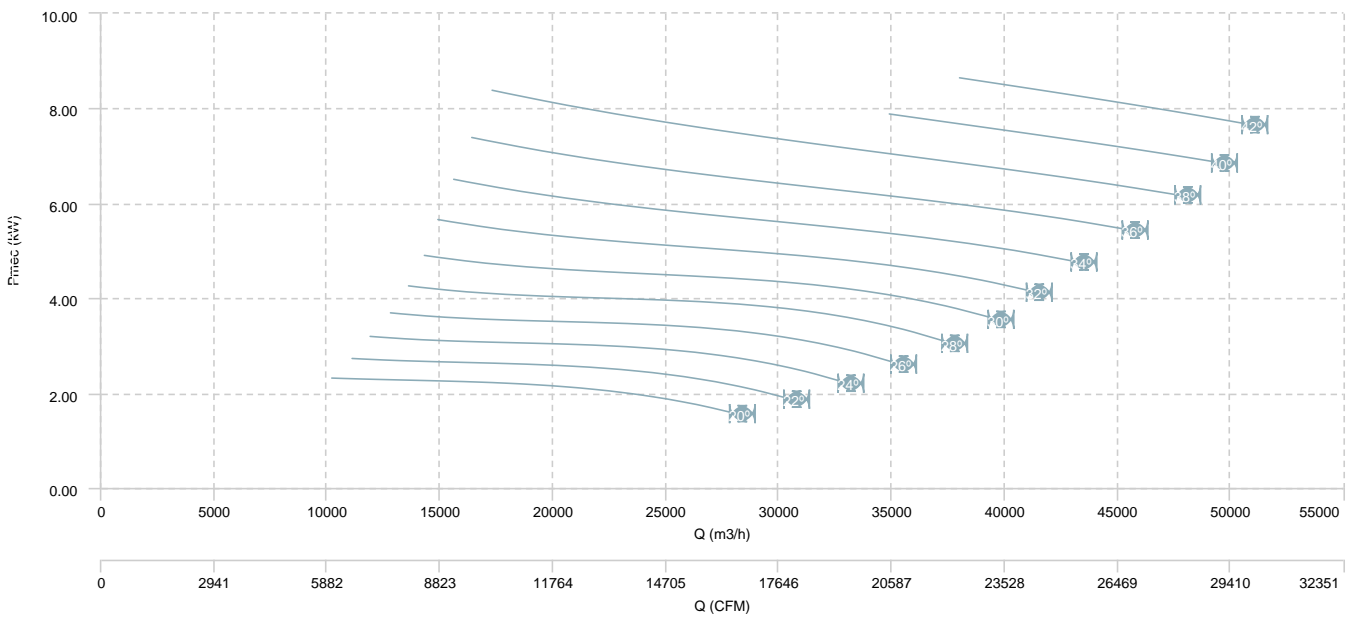

HMX 90 T4 (A6:6)

AIR FLOW - PRESSURE

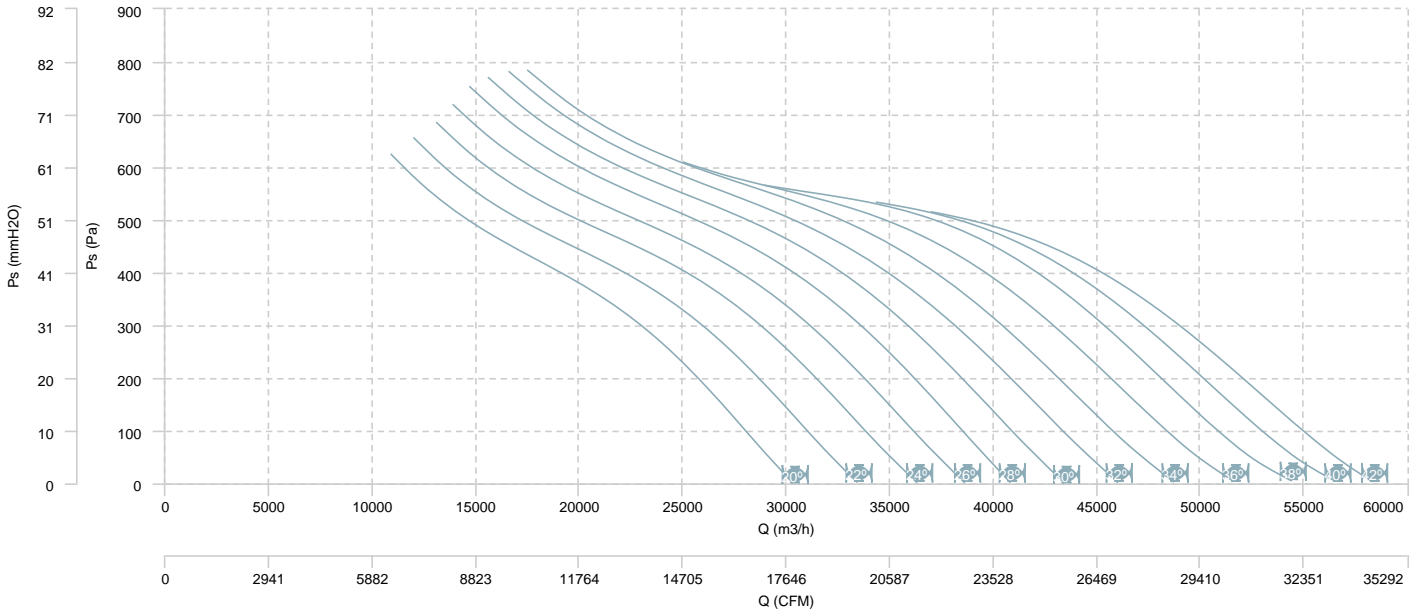

AIR FLOW - MECHANICAL POWER

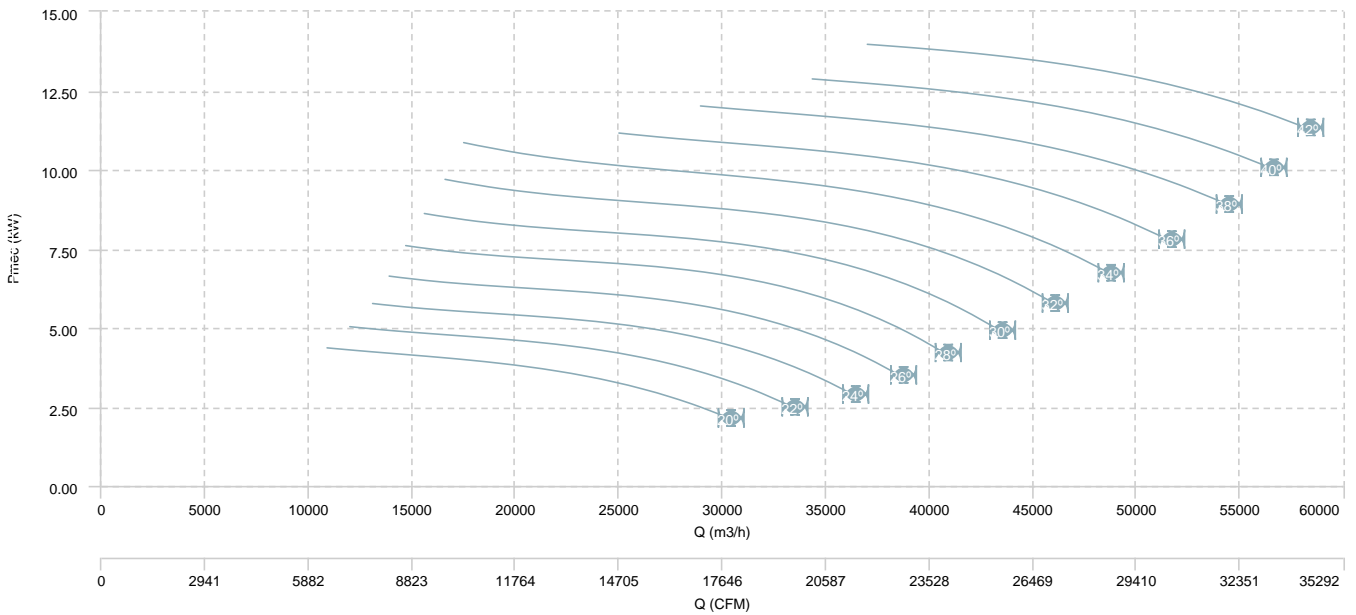

HMX 90 T6 (A6:3)

AIR FLOW - PRESSURE

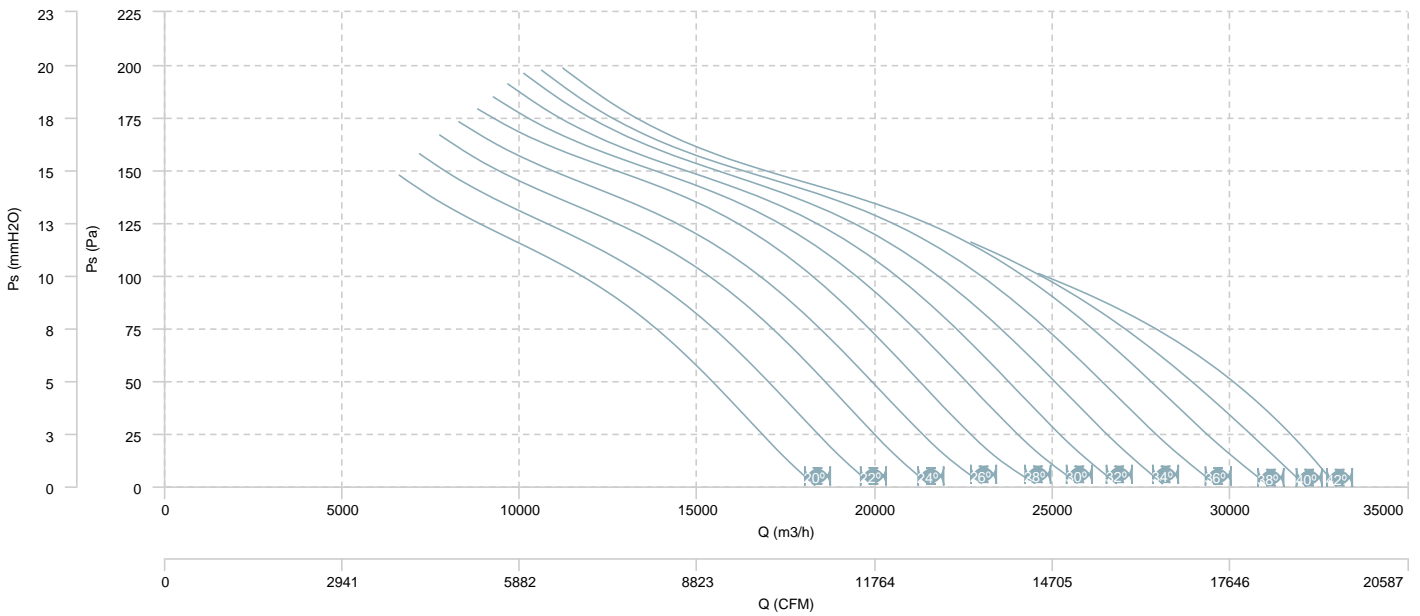

AIR FLOW - MECHANICAL POWER

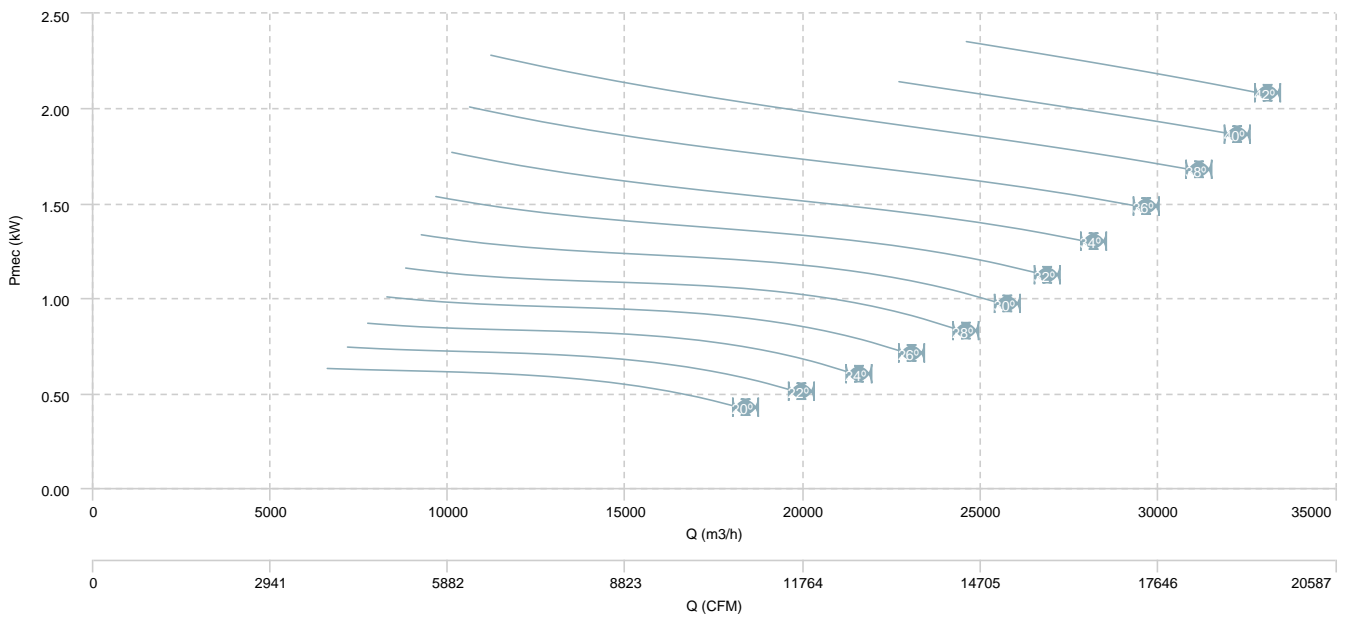

HMX 90 T6 (A6:6)

AIR FLOW - PRESSURE

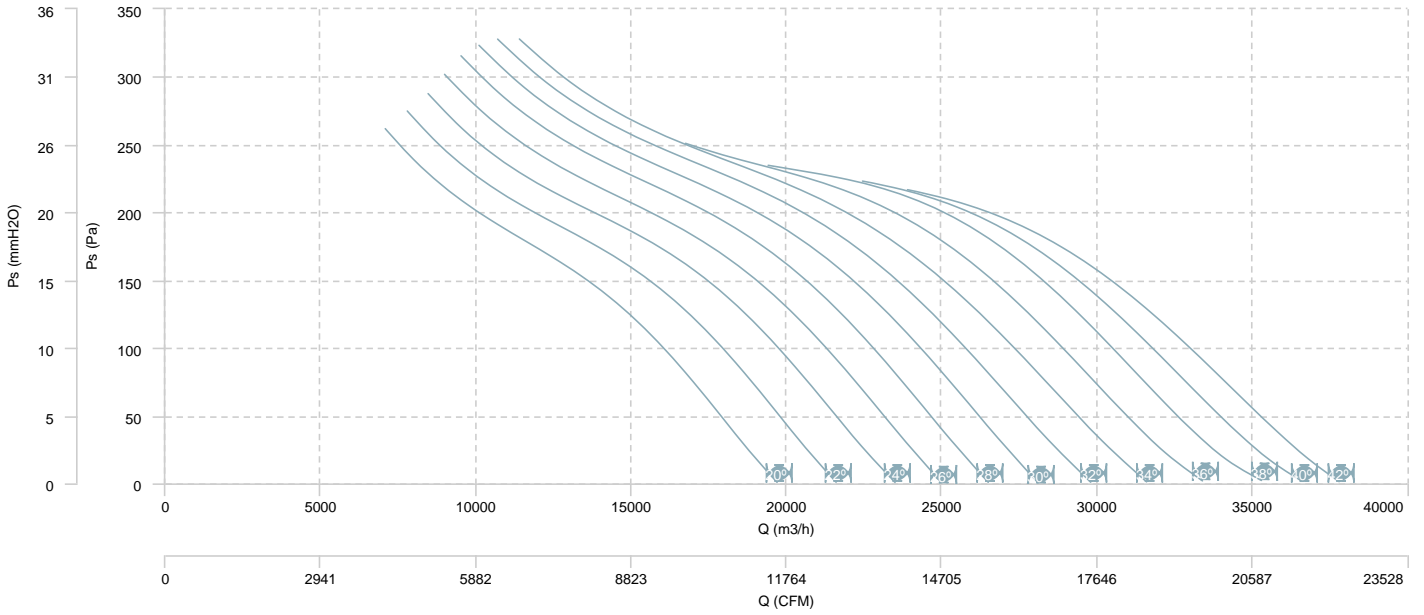

AIR FLOW - MECHANICAL POWER

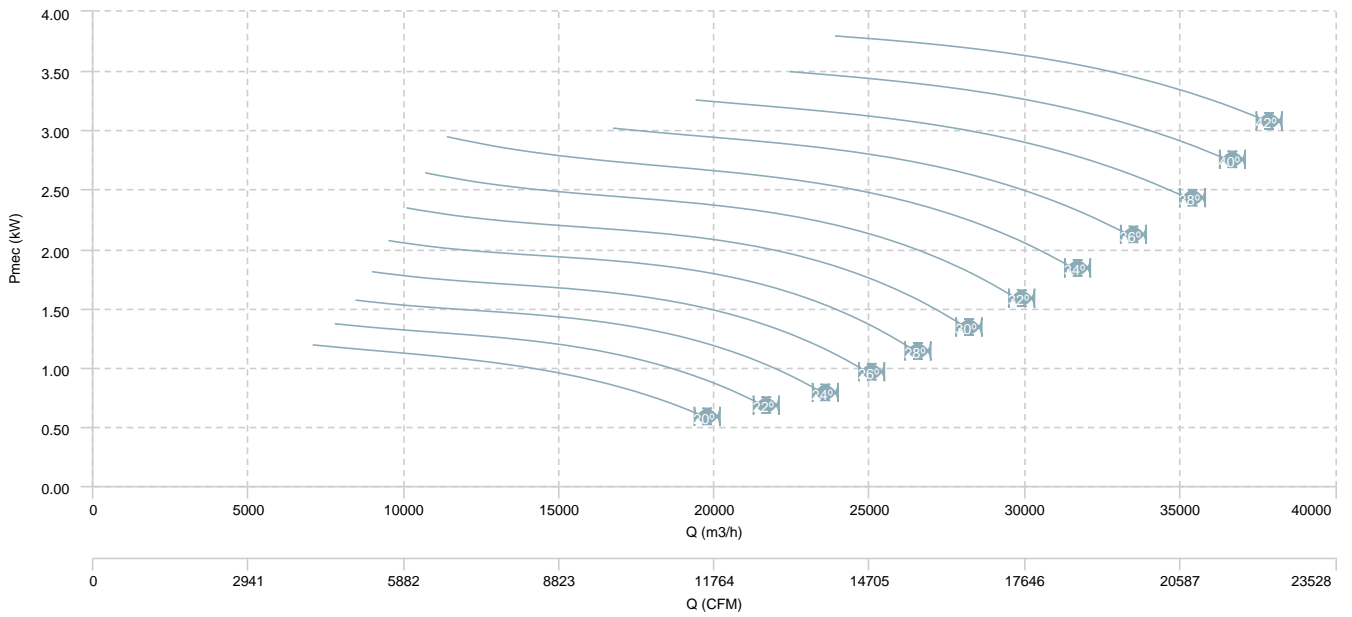

HMX 100 T4 (A6:3)

AIR FLOW - PRESSURE

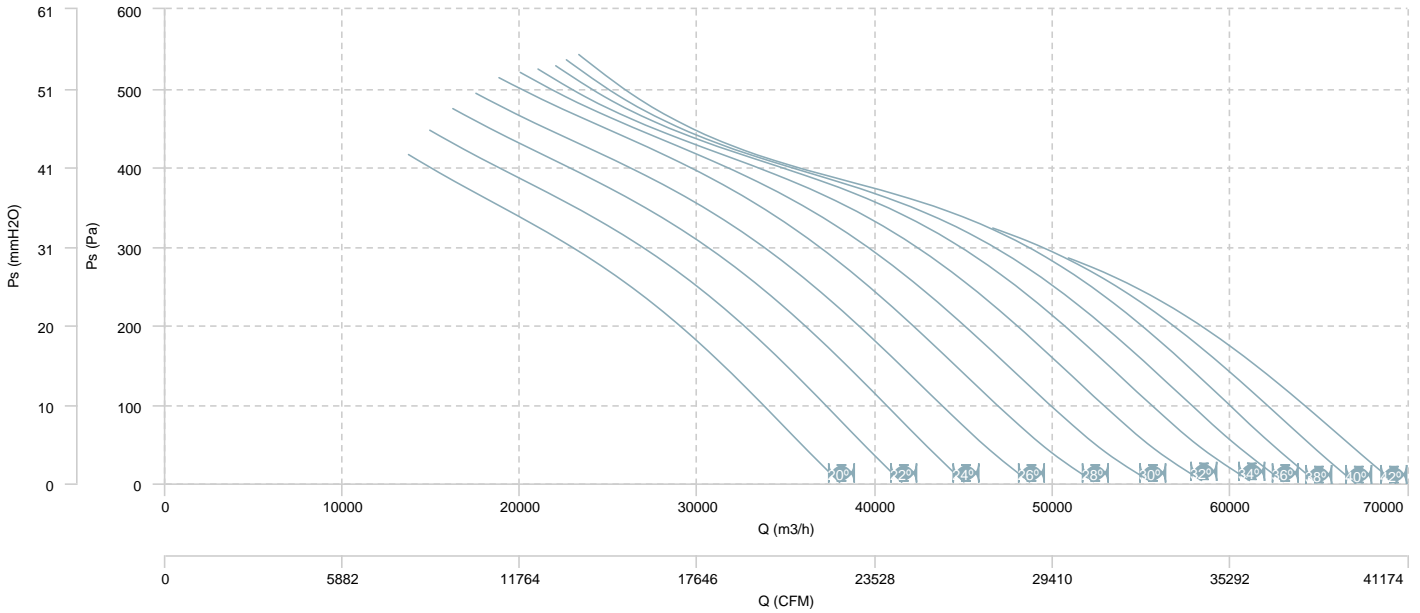

AIR FLOW - MECHANICAL POWER

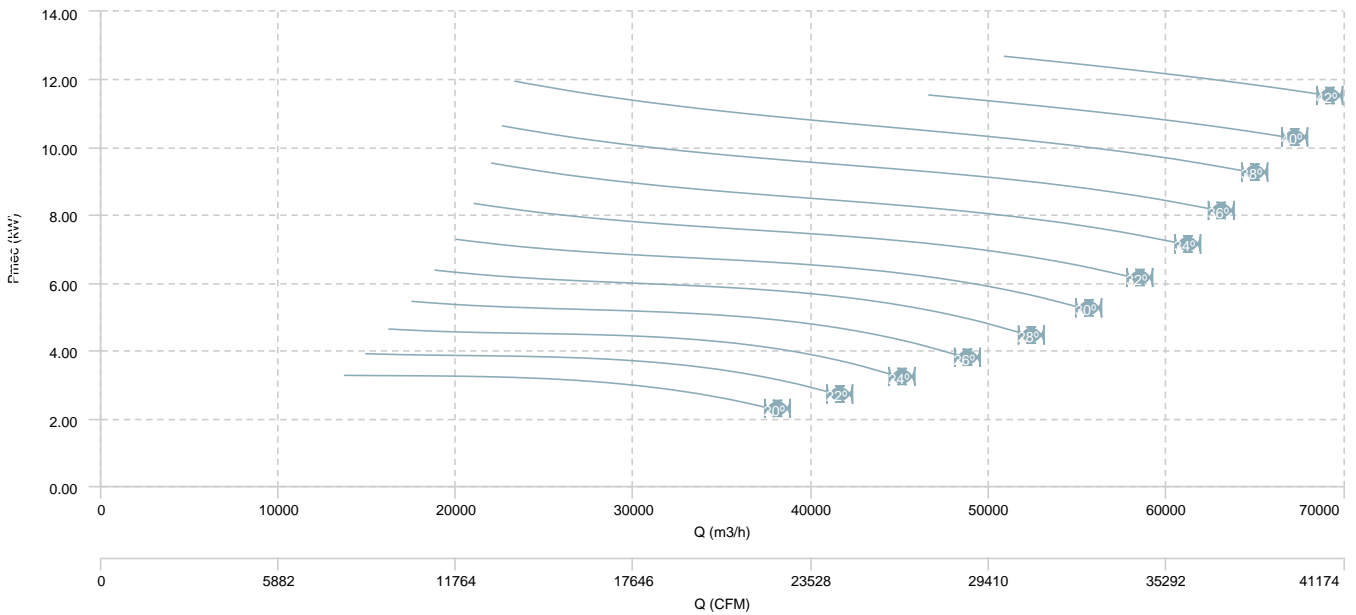

HMX 100 T4 (A6:6)

AIR FLOW - PRESSURE

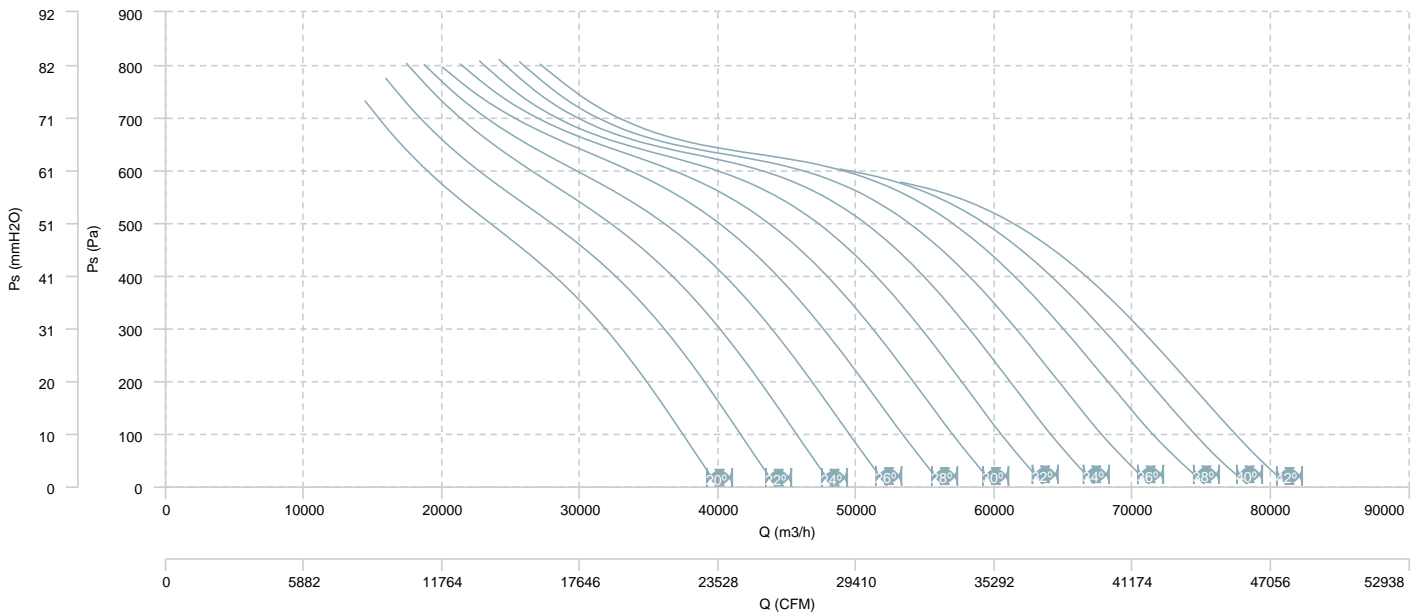

AIR FLOW - MECHANICAL POWER

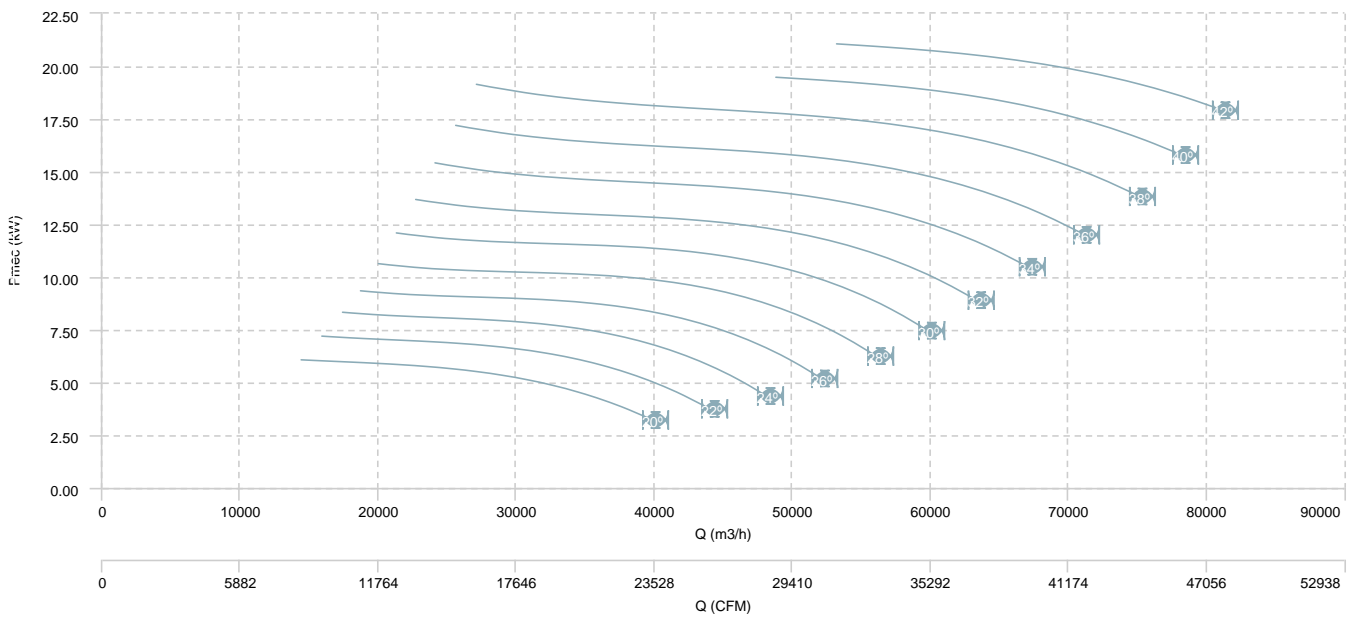

HMX 100 T6 (A6:6)

AIR FLOW - PRESSURE

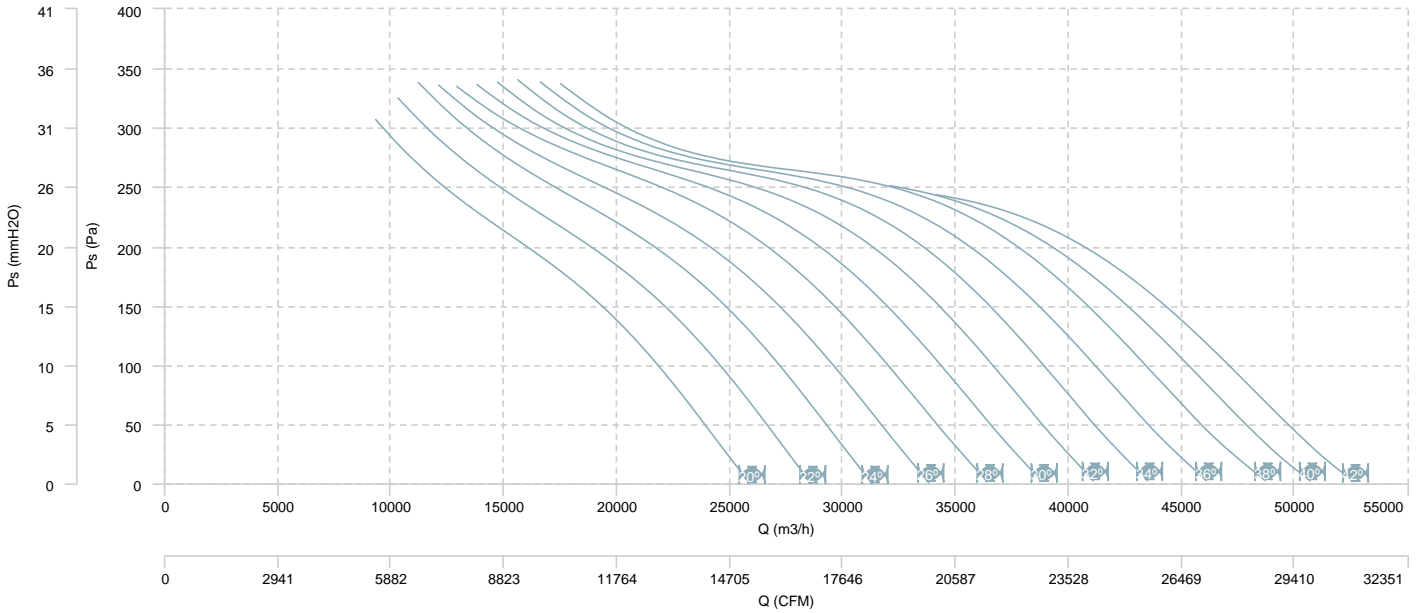

AIR FLOW - MECHANICAL POWER

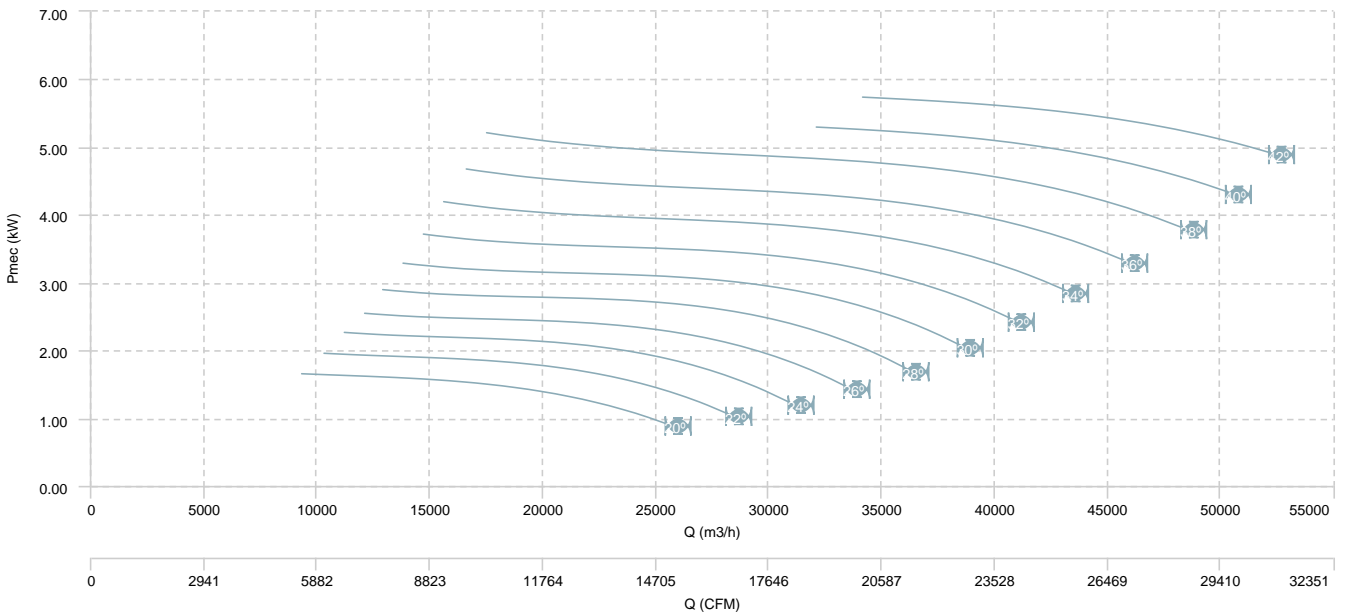

HMX 100 T6 (A6:3)

AIR FLOW - PRESSURE

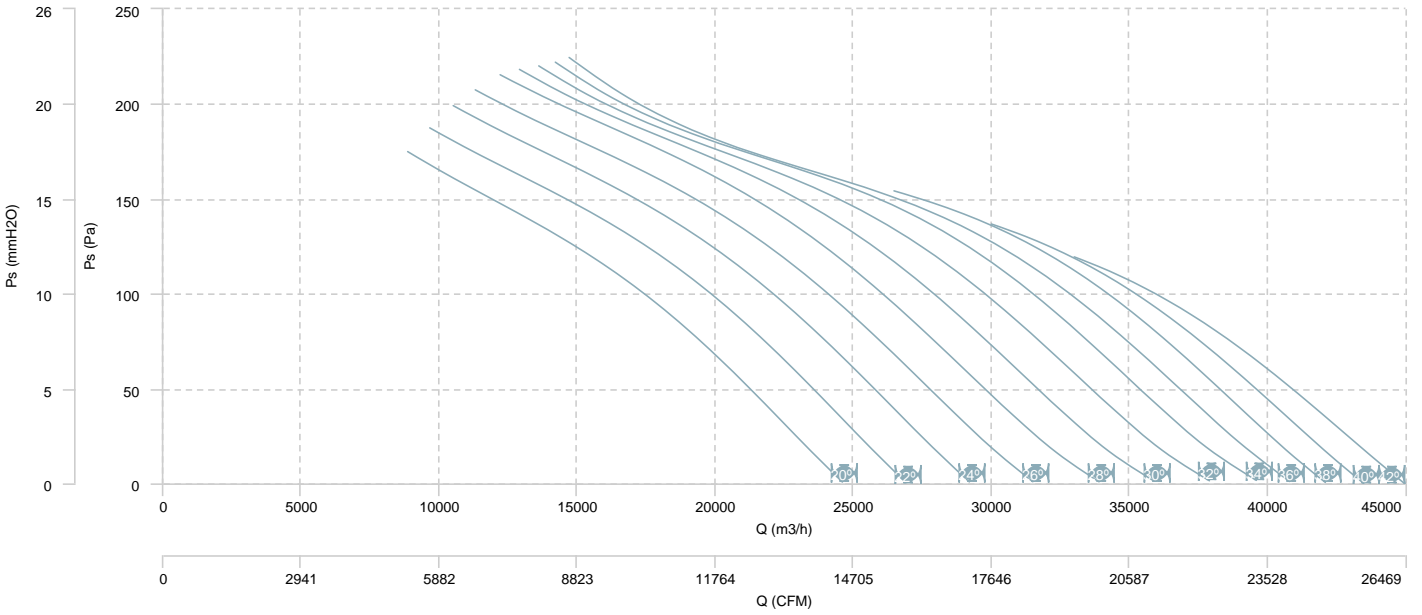

AIR FLOW - MECHANICAL POWER

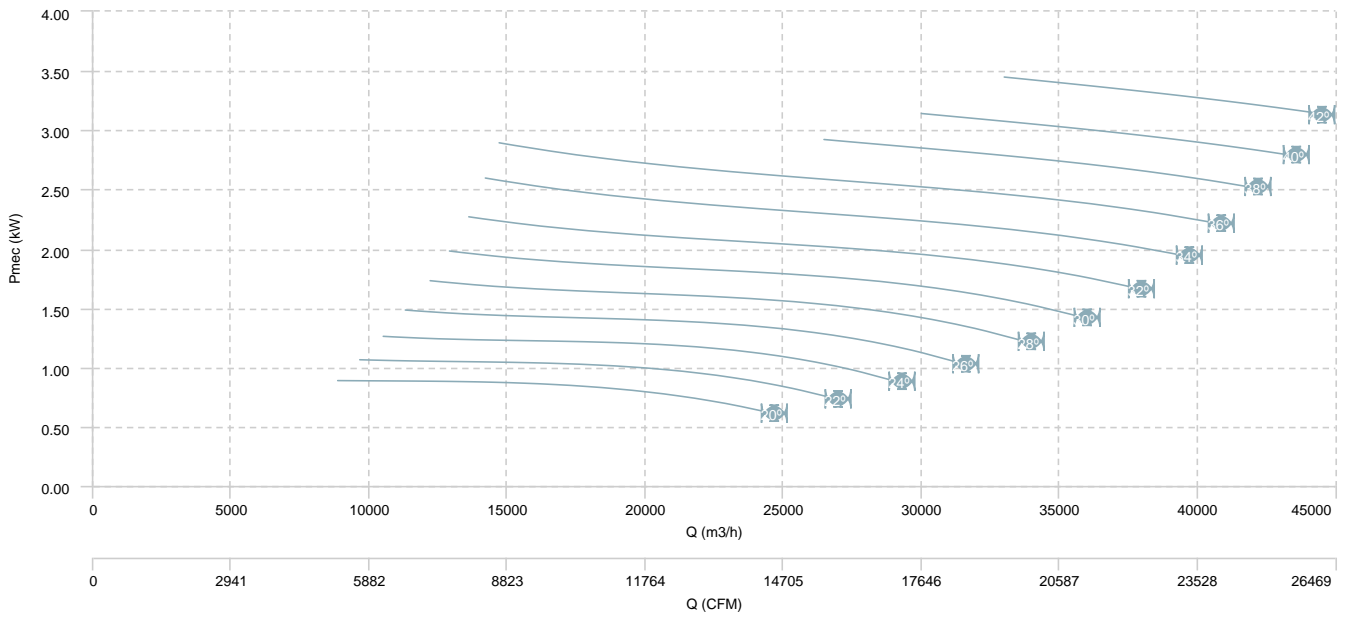

HMX 112 T4 (A6:3)

AIR FLOW - PRESSURE

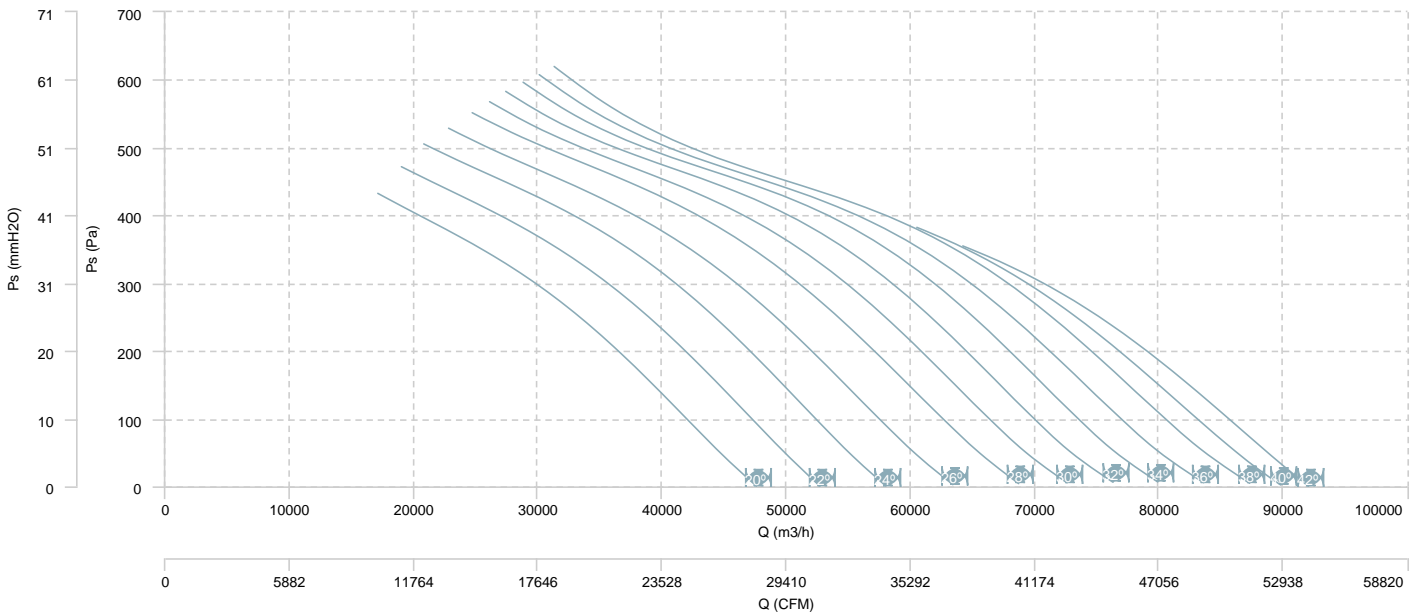

AIR FLOW - MECHANICAL POWER

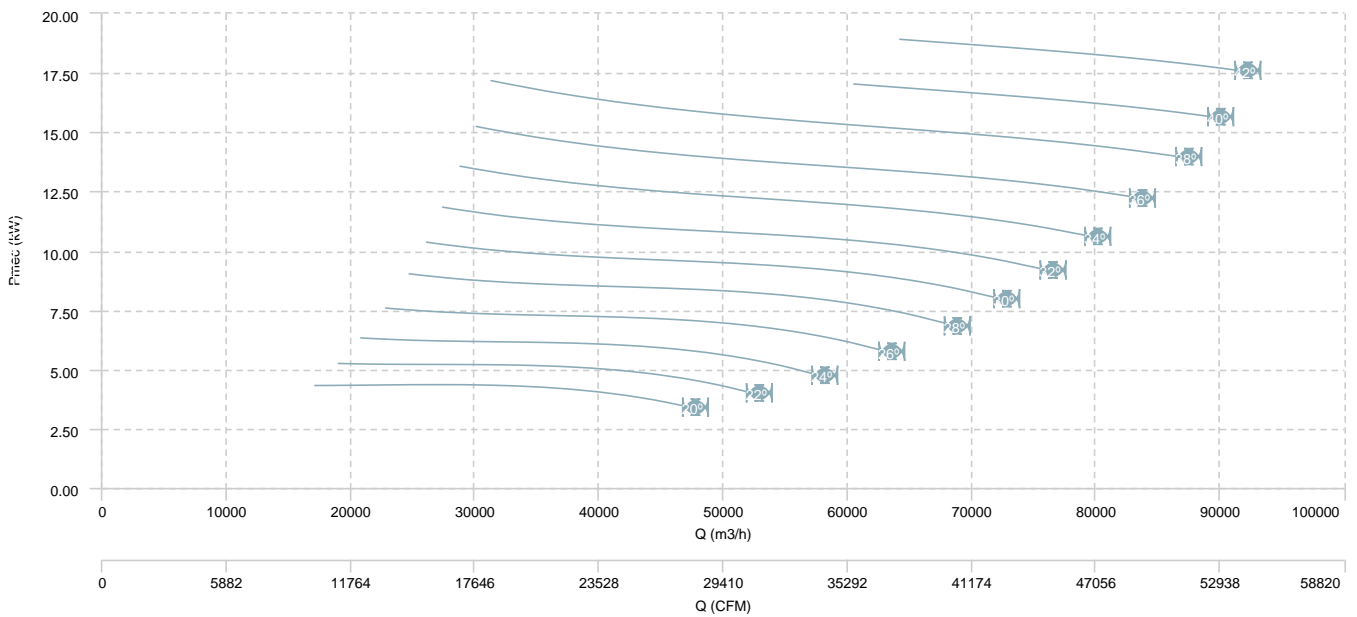

HMX 112 T4 (A6:6)

AIR FLOW - PRESSURE

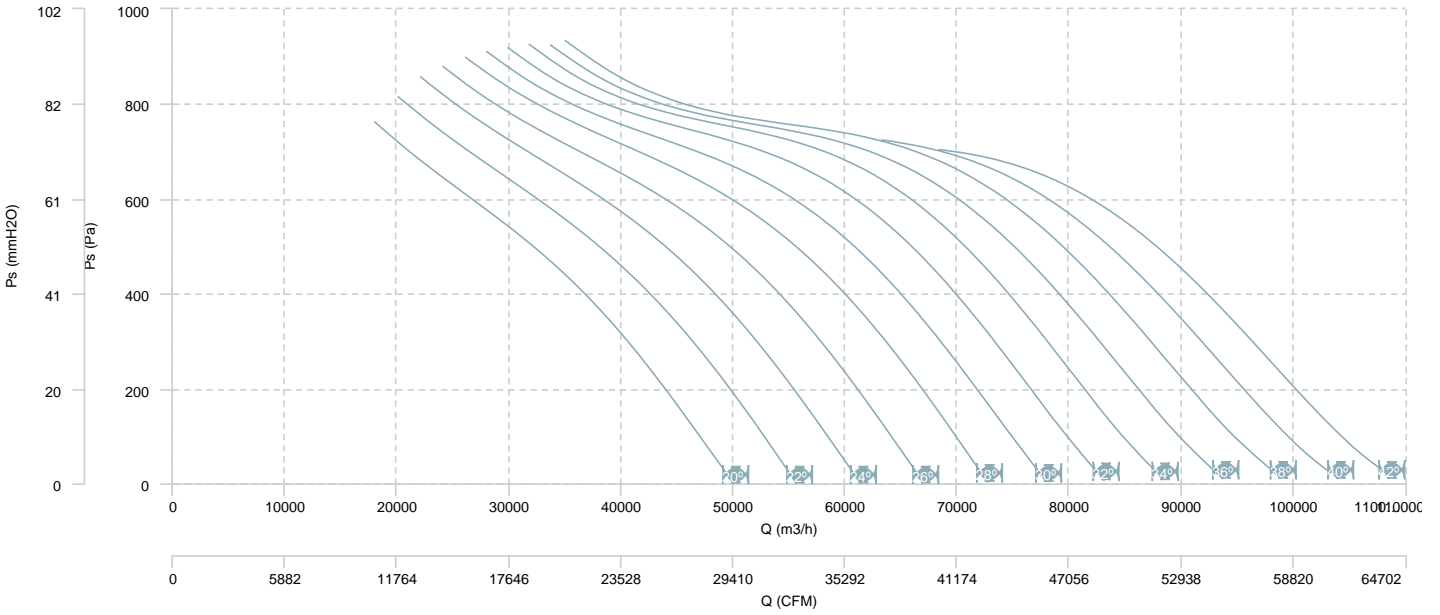

AIR FLOW - MECHANICAL POWER

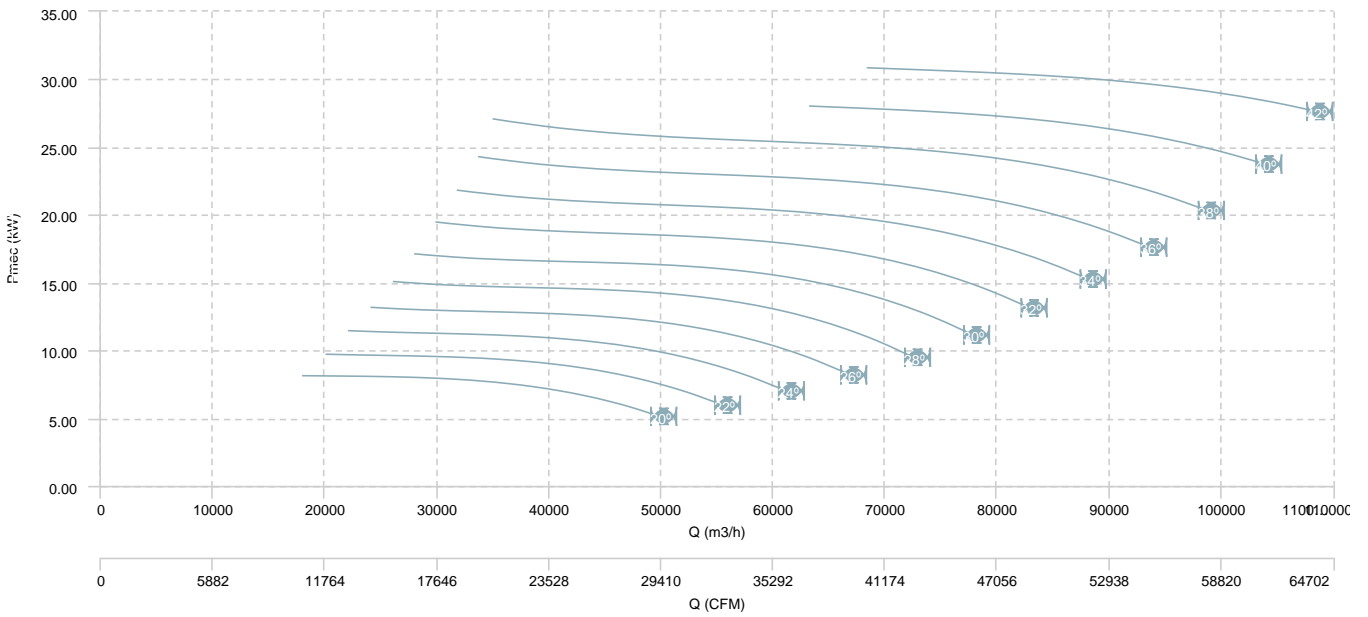

HMX 112 T6 (A6:3)

AIR FLOW - PRESSURE

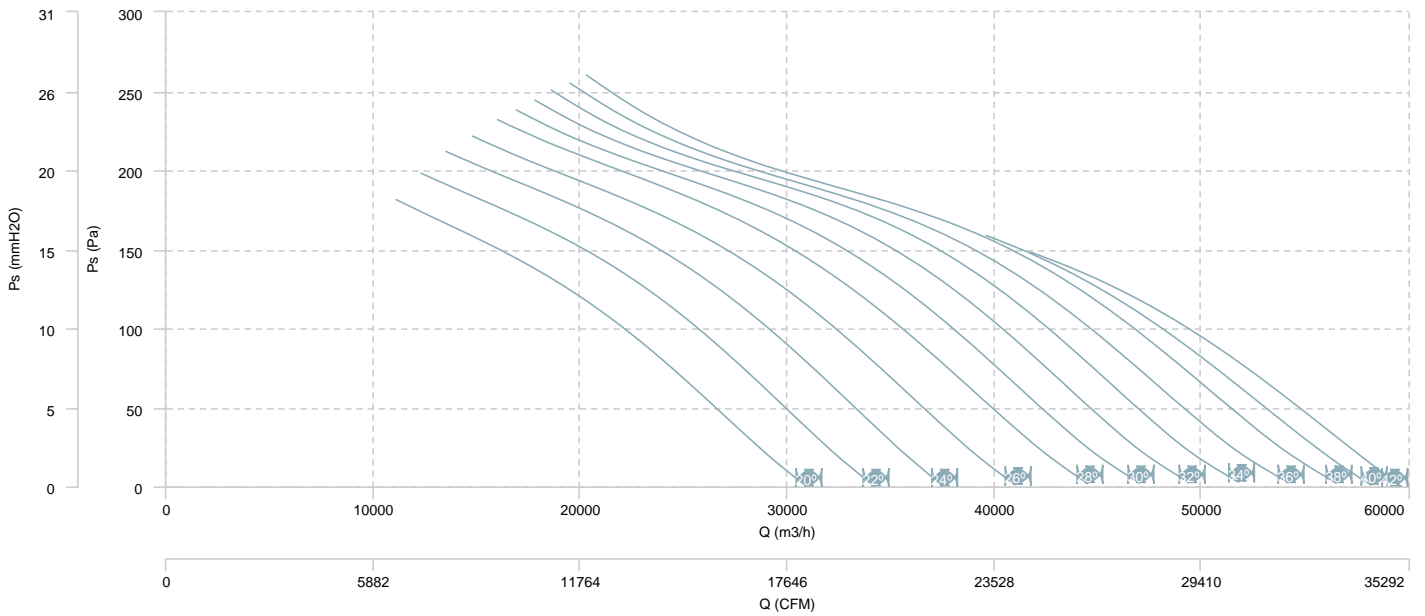

AIR FLOW - MECHANICAL POWER

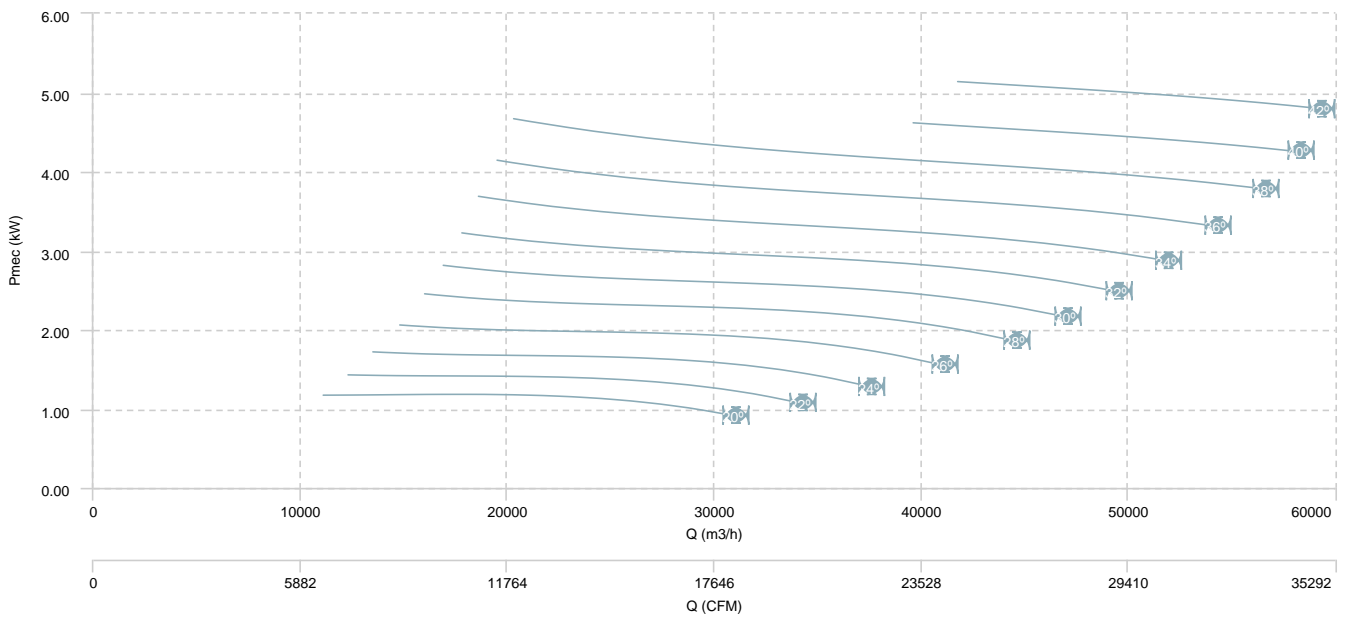

HMX 112 T6 (A6:6)

AIR FLOW - PRESSURE

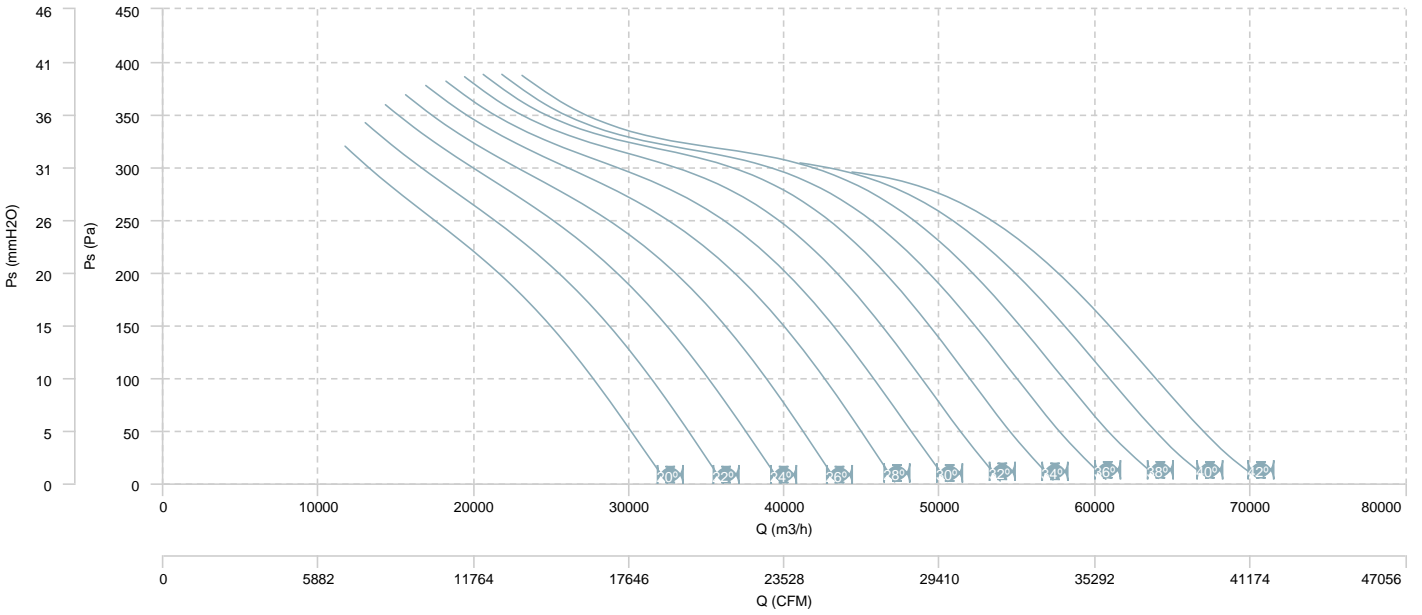

AIR FLOW - MECHANICAL POWER

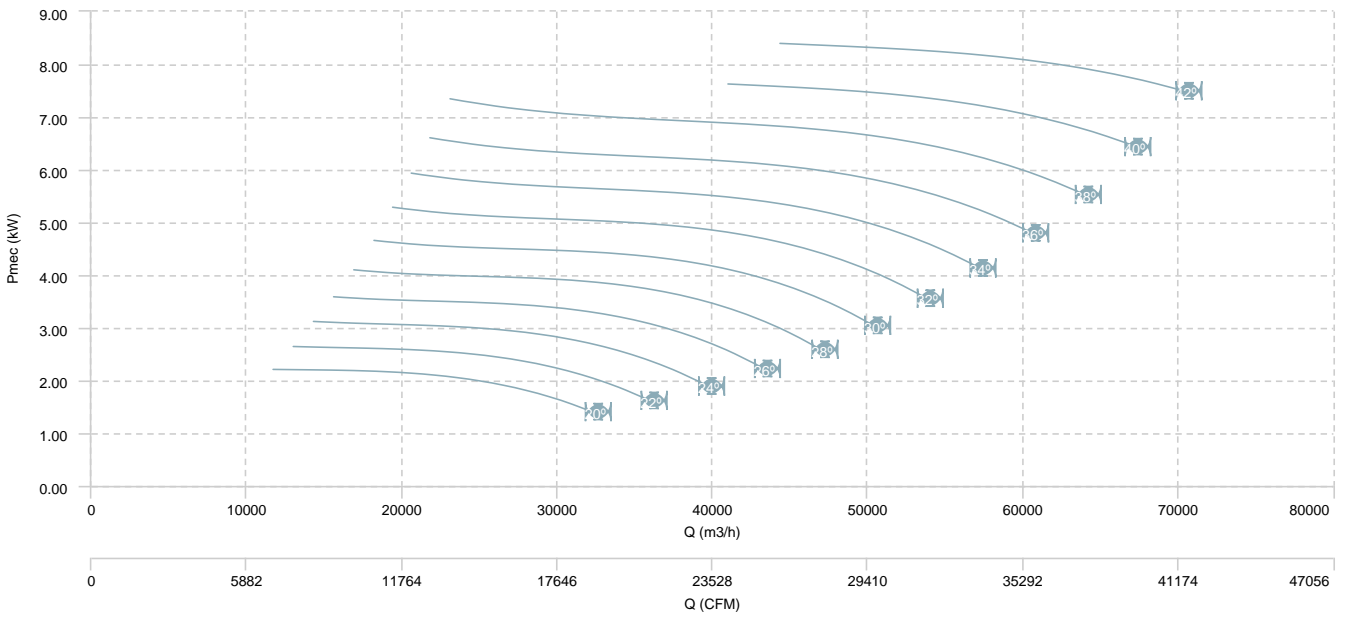

HMX 125 T4 (A7:4)

AIR FLOW - PRESSURE

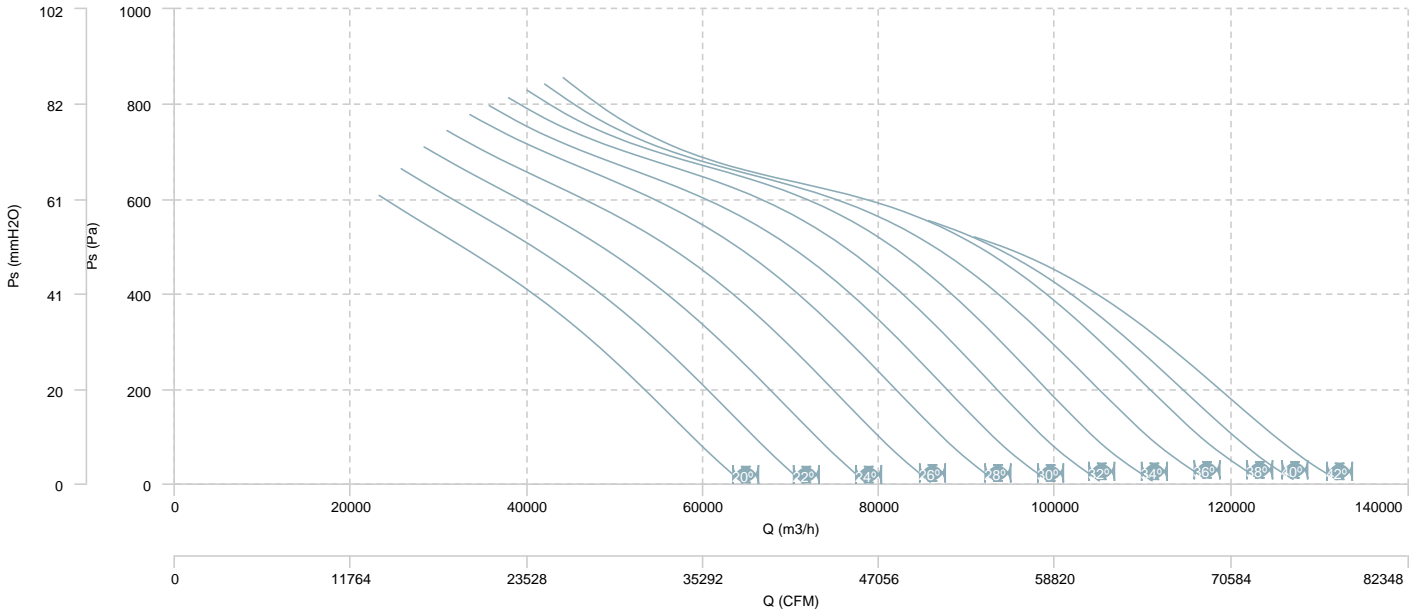

AIR FLOW - MECHANICAL POWER

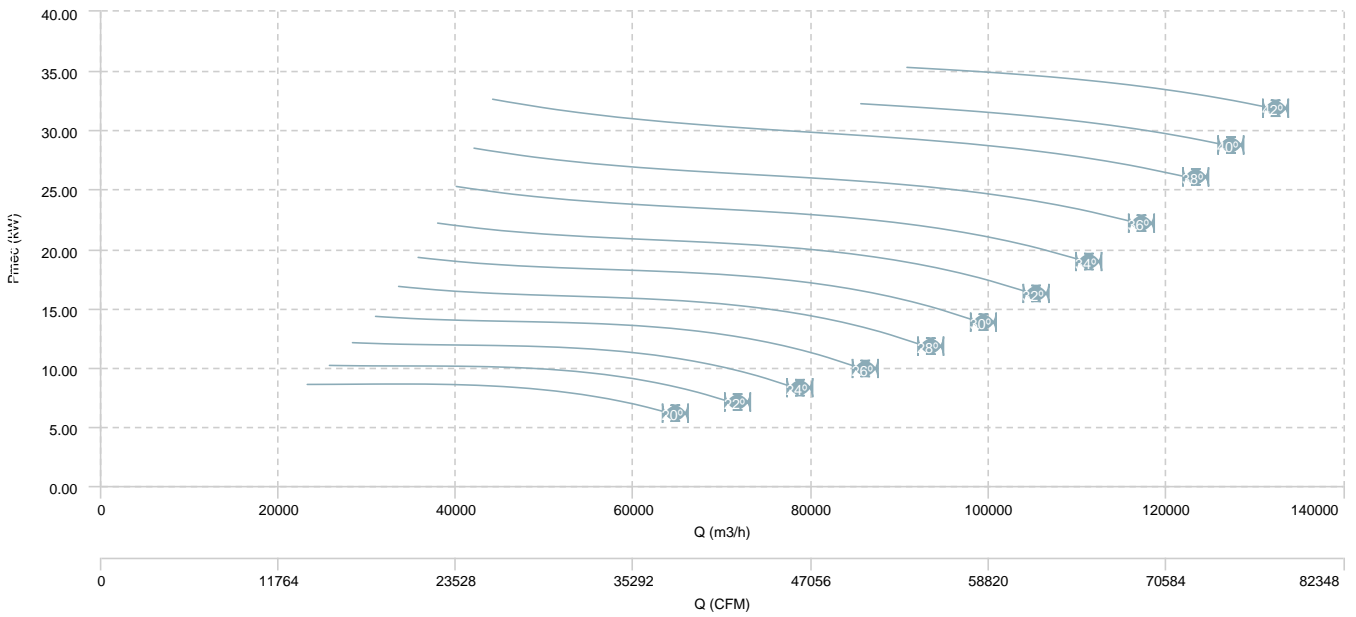

HMX 125 T4 (A7:8)

AIR FLOW - PRESSURE

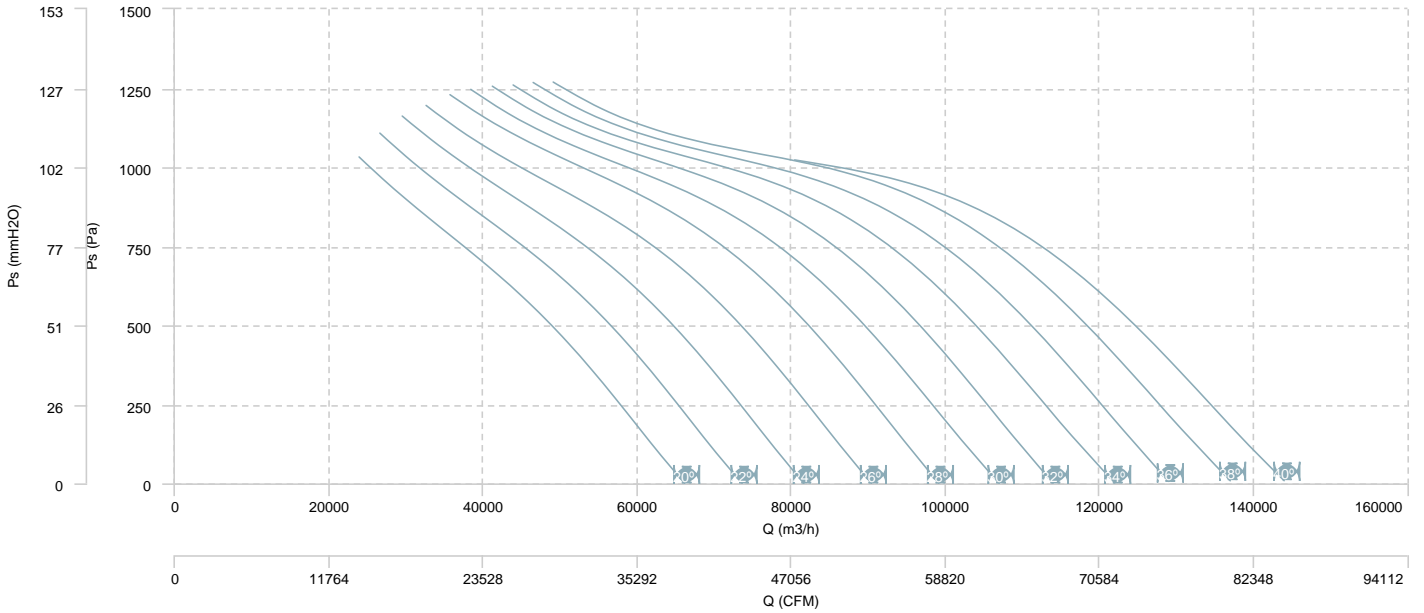

AIR FLOW - MECHANICAL POWER

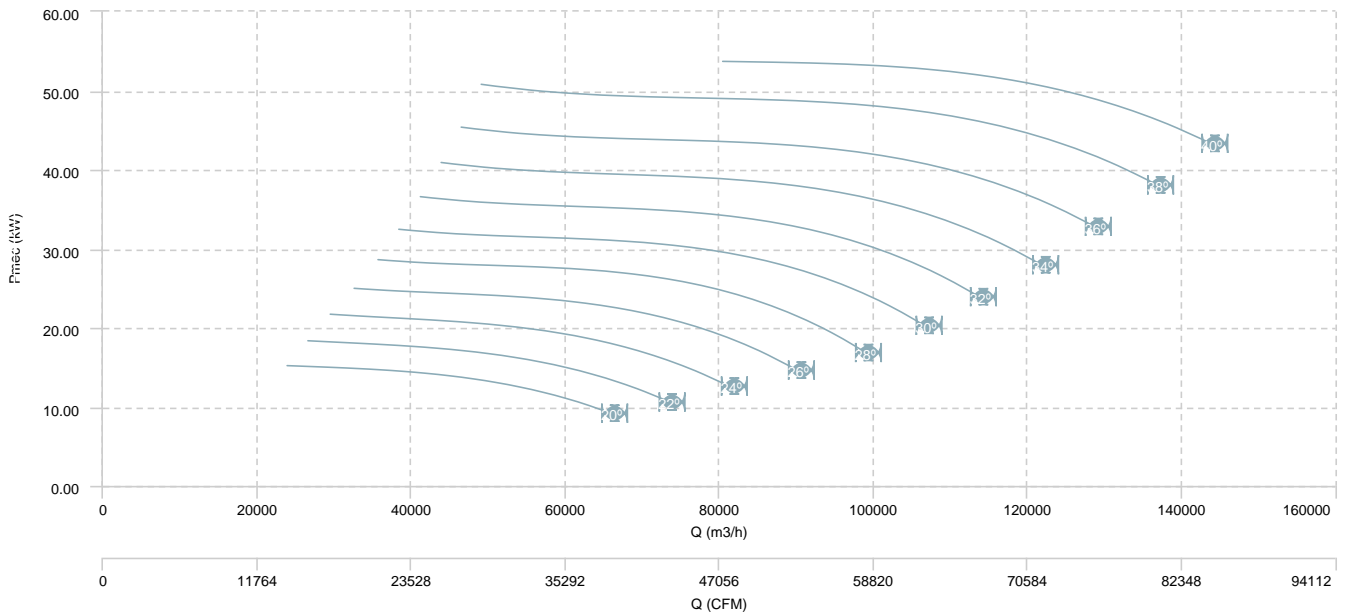

HMX 125 T6 (A7:4)

AIR FLOW - PRESSURE

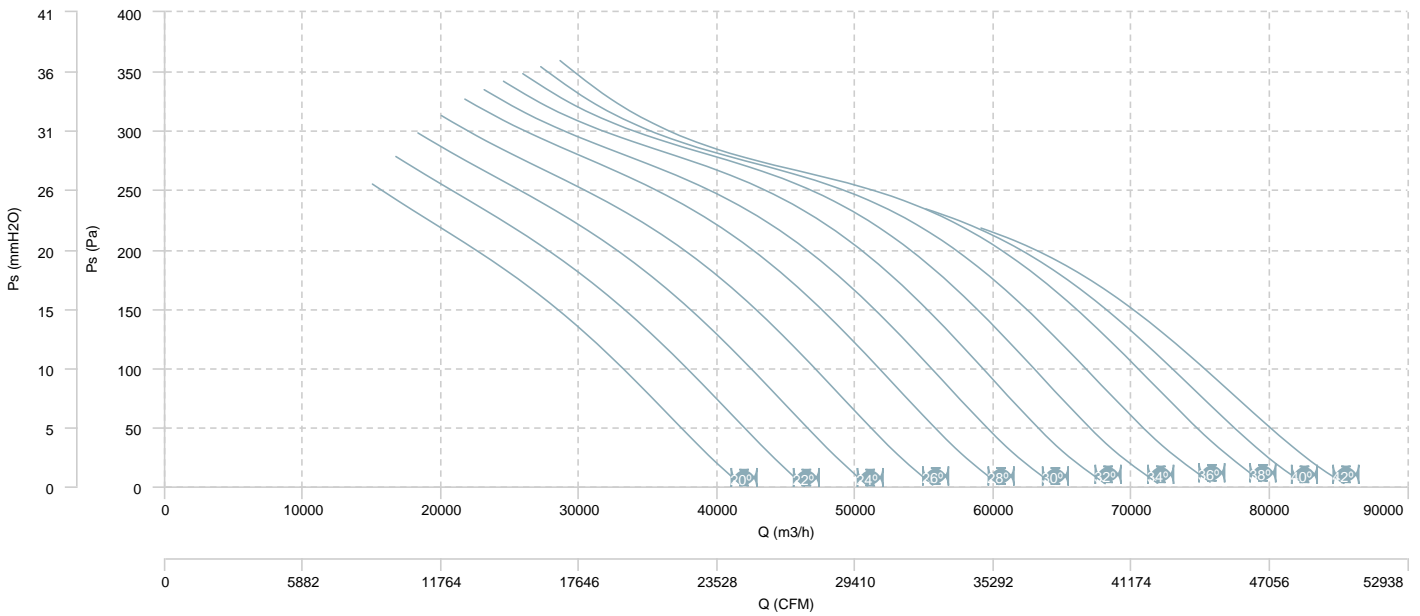

AIR FLOW - MECHANICAL POWER

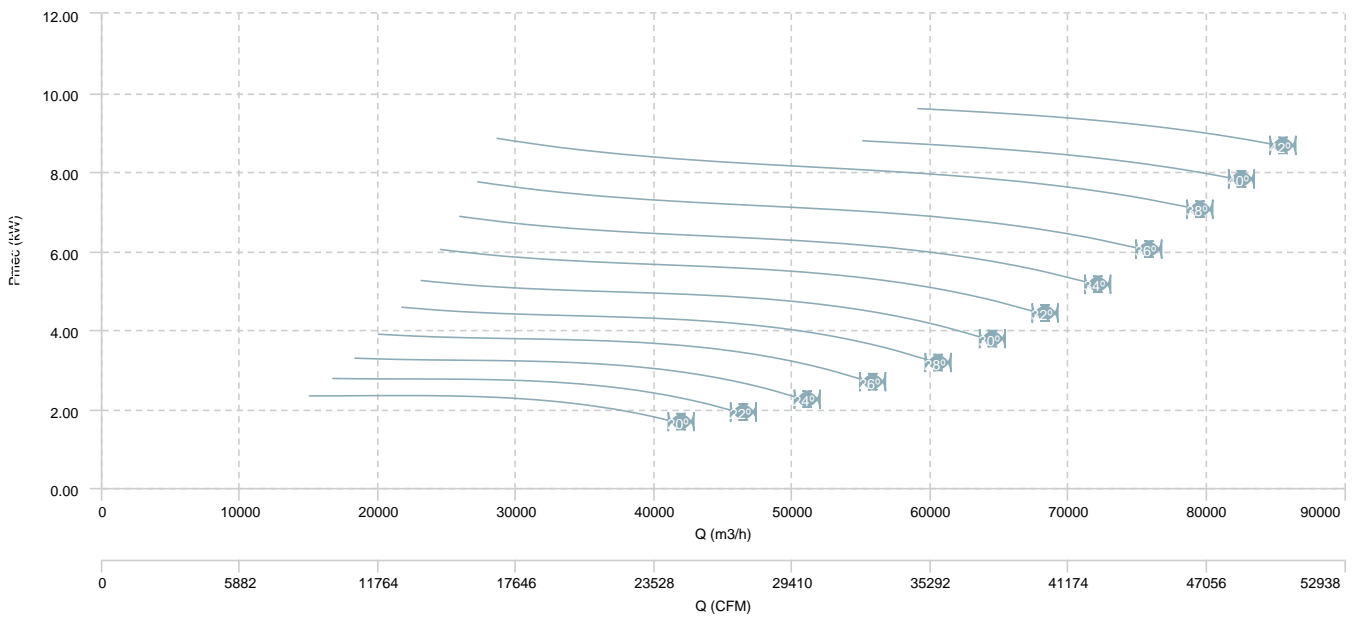

HMX 125 T6 (A7:8)

AIR FLOW - PRESSURE

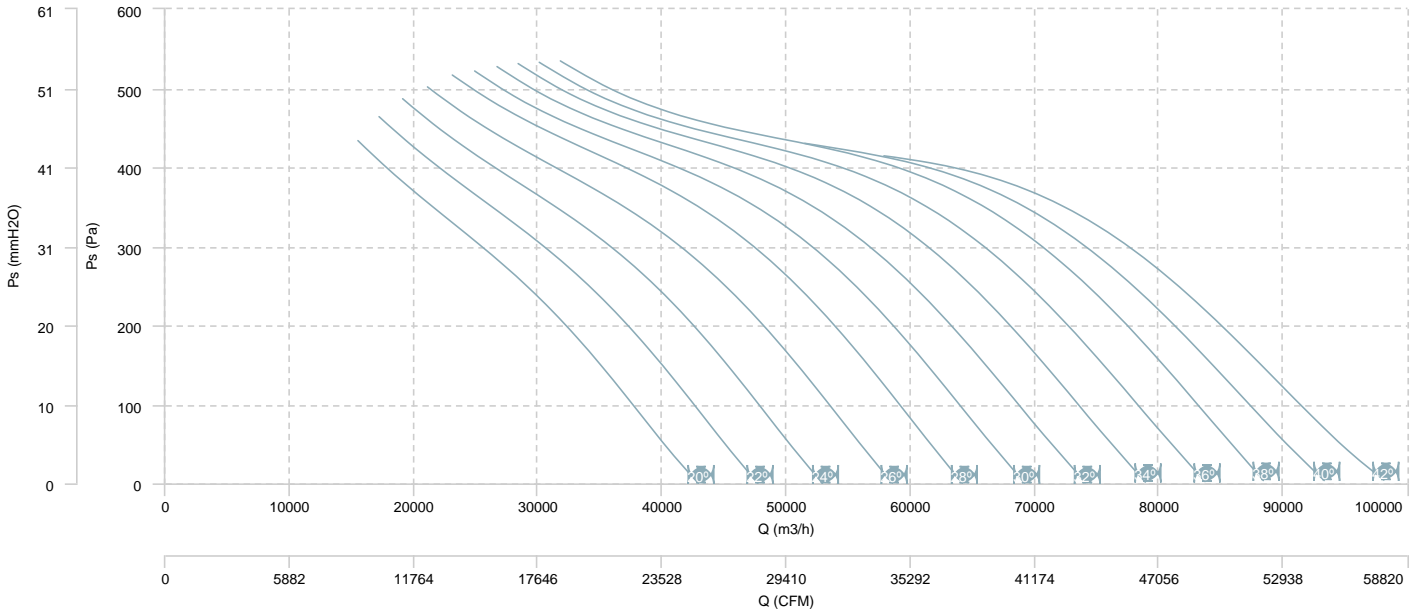

AIR FLOW - MECHANICAL POWER

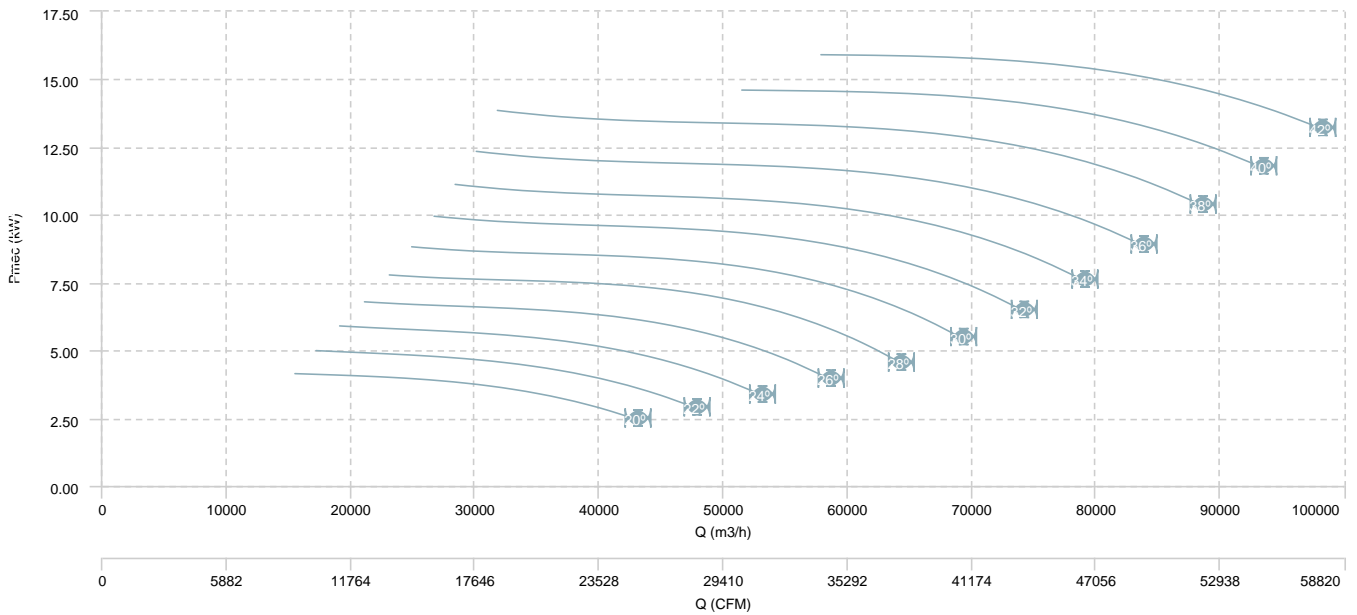

Sound data

Sound / 4 poles

Sound power Lw dB (A)										
Model		63 Hz	125 Hz	250 Hz	500 Hz	1000 Hz	2000 Hz	4000 Hz	8000 Hz	Total
HMX 35 T4 (A0:6) (35º)	Inlet	65	63	62	60	60	59	61	57	71
HMX 35 T4 (A0:6) (40º)	Inlet	67	65	64	62	61	61	62	58	72
HMX 40 T4 (A0:6) (35º)	Inlet	69	66	64	62	63	63	64	59	74
HMX 40 T4 (A0:6) (40º)	Inlet	73	69	68	66	66	66	66	62	77
HMX 45 T4 (A0:6) (35º)	Inlet	71	68	66	65	65	64	66	62	76
HMX 45 T4 (A0:6) (40º)	Inlet	73	70	68	67	66	66	67	62	78
HMX 45 T4 (A5:6) (25º)	Inlet	45	50	57	64	63	64	66	59	71
HMX 45 T4 (A5:6) (30º)	Inlet	48	53	60	64	66	67	68	59	73
HMX 45 T4 (A5:6) (35º)	Inlet	50	54	62	63	68	68	69	59	74
HMX 45 T4 (A5:6) (40º)	Inlet	53	56	65	66	70	70	71	62	76
HMX 45 T4 (A5:6) (45º)	Inlet	52	56	64	67	71	71	72	64	77
HMX 50 T4 (A0:6) (35º)	Inlet	72	69	69	66	66	64	66	61	77
HMX 50 T4 (A0:6) (40º)	Inlet	75	72	70	68	69	67	68	63	79
HMX 50 T4 (A5:6) (25º)	Inlet	44	51	56	61	64	66	68	60	72
HMX 50 T4 (A5:6) (30º)	Inlet	47	52	59	63	66	67	70	61	74
HMX 50 T4 (A5:6) (35º)	Inlet	49	54	61	67	69	70	72	63	77
HMX 50 T4 (A5:6) (40º)	Inlet	49	56	61	67	69	70	72	63	77
HMX 50 T4 (A5:6) (45º)	Inlet	52	59	64	72	73	73	75	67	80
HMX 56 T4 (A5:6) (20º)	Inlet	66	73	78	79	80	78	76	68	86
HMX 56 T4 (A5:6) (25º)	Inlet	53	62	67	73	75	75	76	67	82
HMX 56 T4 (A5:6) (30º)	Inlet	62	72	79	81	81	79	77	69	87
HMX 56 T4 (A5:6) (35º)	Inlet	50	62	67	73	74	75	76	68	81
HMX 56 T4 (A5:6) (40º)	Inlet	56	69	79	85	84	78	76	67	89
HMX 56 T4 (A5:6) (45º)	Inlet	60	73	88	94	91	80	76	67	96
HMX 63 T4 (A5:6) (20º)	Inlet	69	76	81	82	83	80	79	72	89
HMX 63 T4 (A5:6) (25º)	Inlet	54	63	68	73	77	76	76	70	83
HMX 63 T4 (A5:6) (30º)	Inlet	57	65	75	82	80	79	79	72	87
HMX 63 T4 (A5:6) (35º)	Inlet	53	65	70	74	78	77	79	72	84
HMX 63 T4 (A5:6) (40º)	Inlet	54	66	77	89	86	81	79	71	92
HMX 63 T4 (A5:6) (45º)	Inlet	55	66	82	100	92	84	79	71	100
HMX 71 T4 (A5:6) (20º)	Inlet	71	78	83	85	85	83	82	75	92
HMX 71 T4 (A5:6) (25º)	Inlet	58	68	74	78	81	82	82	73	88
HMX 71 T4 (A5:6) (30º)	Inlet	60	68	75	81	82	81	81	72	87
HMX 71 T4 (A5:6) (35º)	Inlet	53	65	70	75	78	79	80	71	84
HMX 71 T4 (A5:6) (40º)	Inlet	57	68	83	92	88	83	81	72	95

Sound power Lw dB (A)										
Model		63 Hz	125 Hz	250 Hz	500 Hz	1000 Hz	2000 Hz	4000 Hz	8000 Hz	Total
HMX 71 T4 (A5:6) (45°)	Inlet	61	70	92	105	96	87	83	72	105
HMX 80 T4 (A5:6) (20°)	Inlet	74	81	86	88	88	86	85	78	94
HMX 80 T4 (A5:6) (25°)	Inlet	61	68	74	79	81	81	82	74	88
HMX 80 T4 (A5:6) (30°)	Inlet	61	72	79	89	87	85	85	77	93
HMX 80 T4 (A5:6) (35°)	Inlet	58	70	76	84	89	87	87	78	94
HMX 80 T4 (A5:6) (40°)	Inlet	59	72	88	93	90	86	84	76	97
HMX 90 T4 (A6:3) (20°)	Inlet	86	79	81	78	79	79	83	79	90
HMX 90 T4 (A6:3) (22°)	Inlet	87	81	82	80	81	81	84	80	92
HMX 90 T4 (A6:3) (24°)	Inlet	88	83	84	82	82	82	85	81	93
HMX 90 T4 (A6:3) (26°)	Inlet	89	84	85	84	83	83	86	82	94
HMX 90 T4 (A6:3) (28°)	Inlet	90	85	86	85	84	84	86	83	95
HMX 90 T4 (A6:3) (30°)	Inlet	91	87	87	87	85	85	87	83	96
HMX 90 T4 (A6:3) (32°)	Inlet	91	87	87	89	86	86	87	84	97
HMX 90 T4 (A6:3) (34°)	Inlet	92	88	88	90	87	87	88	84	97
HMX 90 T4 (A6:3) (36°)	Inlet	92	88	88	91	87	88	88	85	98
HMX 90 T4 (A6:3) (38°)	Inlet	92	89	89	92	89	89	89	86	99
HMX 90 T4 (A6:3) (40°)	Inlet	92	90	90	92	90	90	90	87	99
HMX 90 T4 (A6:3) (42°)	Inlet	93	91	91	93	91	91	91	87	101
HMX 90 T4 (A6:6) (20°)	Inlet	91	91	90	91	92	89	90	87	99
HMX 90 T4 (A6:6) (22°)	Inlet	92	91	90	92	92	90	90	88	100
HMX 90 T4 (A6:6) (24°)	Inlet	93	92	91	92	92	90	91	88	101
HMX 90 T4 (A6:6) (26°)	Inlet	93	93	91	93	92	90	91	89	101
HMX 90 T4 (A6:6) (28°)	Inlet	94	93	92	93	92	91	92	89	102
HMX 90 T4 (A6:6) (30°)	Inlet	95	94	92	93	92	91	92	90	102
HMX 90 T4 (A6:6) (32°)	Inlet	94	93	91	92	90	89	91	88	101
HMX 90 T4 (A6:6) (34°)	Inlet	92	91	89	90	88	88	90	86	99
HMX 90 T4 (A6:6) (36°)	Inlet	92	91	89	89	88	88	89	86	98
HMX 90 T4 (A6:6) (38°)	Inlet	93	92	90	90	88	88	90	86	99
HMX 90 T4 (A6:6) (40°)	Inlet	94	92	90	91	89	89	90	86	100
HMX 90 T4 (A6:6) (42°)	Inlet	94	93	91	91	89	89	90	86	101
HMX 100 T4 (A6:3) (20°)	Inlet	90	87	85	84	87	87	91	85	97
HMX 100 T4 (A6:3) (22°)	Inlet	91	88	86	86	87	88	91	86	97
HMX 100 T4 (A6:3) (24°)	Inlet	92	88	87	86	87	87	90	86	97
HMX 100 T4 (A6:3) (26°)	Inlet	92	88	87	86	87	87	90	85	97
HMX 100 T4 (A6:3) (28°)	Inlet	92	88	87	86	86	87	89	85	97
HMX 100 T4 (A6:3) (30°)	Inlet	92	88	87	87	86	86	88	84	97
HMX 100 T4 (A6:3) (32°)	Inlet	94	89	89	88	87	87	89	85	98
HMX 100 T4 (A6:3) (34°)	Inlet	95	91	90	90	89	89	89	86	100
HMX 100 T4 (A6:3) (36°)	Inlet	95	91	91	91	90	89	90	87	101

Sound power Lw dB (A)										
Model		63 Hz	125 Hz	250 Hz	500 Hz	1000 Hz	2000 Hz	4000 Hz	8000 Hz	Total
HMX 100 T4 (A6:3) (38°)	Inlet	95	92	91	92	90	90	90	87	101
HMX 100 T4 (A6:3) (40°)	Inlet	95	93	91	93	91	91	91	88	101
HMX 100 T4 (A6:3) (42°)	Inlet	95	93	92	93	92	92	92	89	102
HMX 100 T4 (A6:6) (20°)	Inlet	95	96	94	98	96	94	94	92	105
HMX 100 T4 (A6:6) (22°)	Inlet	95	96	94	98	95	94	94	92	105
HMX 100 T4 (A6:6) (24°)	Inlet	96	96	94	97	95	94	94	92	104
HMX 100 T4 (A6:6) (26°)	Inlet	97	97	95	97	95	94	95	92	105
HMX 100 T4 (A6:6) (28°)	Inlet	99	97	96	98	95	94	95	93	106
HMX 100 T4 (A6:6) (30°)	Inlet	99	97	96	97	95	94	96	93	106
HMX 100 T4 (A6:6) (32°)	Inlet	98	97	95	95	94	93	94	91	105
HMX 100 T4 (A6:6) (34°)	Inlet	98	96	95	93	92	92	93	90	104
HMX 100 T4 (A6:6) (36°)	Inlet	97	95	94	92	92	91	93	89	103
HMX 100 T4 (A6:6) (38°)	Inlet	98	96	95	93	92	92	93	90	104
HMX 100 T4 (A6:6) (40°)	Inlet	99	97	95	94	93	93	94	90	105
HMX 100 T4 (A6:6) (42°)	Inlet	98	96	95	94	93	93	94	90	104
HMX 112 T4 (A6:3) (20°)	Inlet	93	90	88	89	91	91	93	90	101
HMX 112 T4 (A6:3) (22°)	Inlet	95	92	90	90	92	92	94	91	102
HMX 112 T4 (A6:3) (24°)	Inlet	96	93	91	91	92	92	94	91	102
HMX 112 T4 (A6:3) (26°)	Inlet	97	93	92	92	92	92	95	91	103
HMX 112 T4 (A6:3) (28°)	Inlet	97	93	92	92	92	92	94	91	103
HMX 112 T4 (A6:3) (30°)	Inlet	97	93	92	92	92	91	94	91	103
HMX 112 T4 (A6:3) (32°)	Inlet	98	93	93	92	92	91	93	91	103
HMX 112 T4 (A6:3) (34°)	Inlet	99	93	94	93	92	91	93	91	103
HMX 112 T4 (A6:3) (36°)	Inlet	99	94	94	93	92	92	93	91	104
HMX 112 T4 (A6:3) (38°)	Inlet	99	95	94	94	93	92	93	91	104
HMX 112 T4 (A6:3) (40°)	Inlet	99	95	94	94	93	93	93	91	104
HMX 112 T4 (A6:3) (42°)	Inlet	99	96	94	95	94	94	94	91	104
HMX 112 T4 (A6:6) (20°)	Inlet	95	96	95	101	98	96	97	94	106
HMX 112 T4 (A6:6) (22°)	Inlet	96	96	95	99	98	96	97	94	106
HMX 112 T4 (A6:6) (24°)	Inlet	97	96	95	98	97	95	96	93	106
HMX 112 T4 (A6:6) (26°)	Inlet	98	97	95	98	97	96	97	93	106
HMX 112 T4 (A6:6) (28°)	Inlet	100	98	96	98	97	96	97	93	107
HMX 112 T4 (A6:6) (30°)	Inlet	101	98	96	97	96	96	97	92	107
HMX 112 T4 (A6:6) (32°)	Inlet	101	97	95	95	95	95	96	91	106
HMX 112 T4 (A6:6) (34°)	Inlet	100	97	95	94	94	94	95	90	105
HMX 112 T4 (A6:6) (36°)	Inlet	101	98	96	94	94	94	95	90	106
HMX 112 T4 (A6:6) (38°)	Inlet	103	99	98	95	96	96	97	92	107
HMX 112 T4 (A6:6) (40°)	Inlet	105	101	99	97	97	97	98	93	109
HMX 112 T4 (A6:6) (42°)	Inlet	105	100	99	97	97	97	97	93	109

Sound power Lw dB (A)										
Model		63 Hz	125 Hz	250 Hz	500 Hz	1000 Hz	2000 Hz	4000 Hz	8000 Hz	Total
HMX 125 T4 (A7:4) (20°)	Inlet	98	102	99	101	102	101	103	102	110
HMX 125 T4 (A7:4) (22°)	Inlet	101	103	101	102	102	102	104	102	111
HMX 125 T4 (A7:4) (24°)	Inlet	102	101	99	99	100	100	102	99	109
HMX 125 T4 (A7:4) (26°)	Inlet	102	100	98	97	98	98	99	96	108
HMX 125 T4 (A7:4) (28°)	Inlet	102	98	96	95	96	97	98	94	107
HMX 125 T4 (A7:4) (30°)	Inlet	100	97	95	93	94	95	96	91	105
HMX 125 T4 (A7:4) (32°)	Inlet	100	97	95	93	93	94	95	90	105
HMX 125 T4 (A7:4) (34°)	Inlet	99	96	94	93	93	94	95	89	105
HMX 125 T4 (A7:4) (36°)	Inlet	100	97	95	93	93	94	95	89	105
HMX 125 T4 (A7:4) (38°)	Inlet	101	98	96	94	94	95	95	90	106
HMX 125 T4 (A7:4) (40°)	Inlet	102	98	96	95	94	95	95	91	106
HMX 125 T4 (A7:4) (42°)	Inlet	102	99	97	95	95	96	96	91	107
HMX 125 T4 (A7:8) (20°)	Inlet	104	102	101	104	107	109	108	105	115
HMX 125 T4 (A7:8) (22°)	Inlet	104	101	101	103	106	108	107	104	114
HMX 125 T4 (A7:8) (24°)	Inlet	104	101	100	102	105	106	106	102	113
HMX 125 T4 (A7:8) (26°)	Inlet	104	100	99	101	103	105	105	101	112
HMX 125 T4 (A7:8) (28°)	Inlet	104	99	99	99	102	104	104	99	111
HMX 125 T4 (A7:8) (30°)	Inlet	103	99	98	98	100	102	102	97	110
HMX 125 T4 (A7:8) (32°)	Inlet	103	99	98	97	99	100	101	95	109
HMX 125 T4 (A7:8) (34°)	Inlet	104	99	98	97	98	99	99	93	109
HMX 125 T4 (A7:8) (36°)	Inlet	104	100	98	97	97	98	98	92	108
HMX 125 T4 (A7:8) (38°)	Inlet	104	101	98	97	97	98	97	92	108
HMX 125 T4 (A7:8) (40°)	Inlet	103	100	98	97	97	98	96	92	108
HMX 125 T4 (A7:8) (42°)	Inlet	103	100	98	97	97	97	96	92	108

Sound / 6 poles

Sound power Lw dB (A)										
Model		63 Hz	125 Hz	250 Hz	500 Hz	1000 Hz	2000 Hz	4000 Hz	8000 Hz	Total
HMX 40 T6 (A0:6) (35°)	Inlet	60	57	55	53	53	54	55	49	64
HMX 40 T6 (A0:6) (40°)	Inlet	64	60	59	56	56	56	57	52	68
HMX 45 T6 (A0:6) (35°)	Inlet	61	59	57	56	56	55	57	52	66
HMX 45 T6 (A0:6) (40°)	Inlet	64	61	59	57	57	56	57	53	68
HMX 45 T6 (A5:6) (25°)	Inlet	36	41	48	55	53	55	57	49	62
HMX 45 T6 (A5:6) (30°)	Inlet	39	44	51	55	57	58	59	50	64
HMX 45 T6 (A5:6) (35°)	Inlet	40	44	52	53	58	58	60	49	65
HMX 45 T6 (A5:6) (40°)	Inlet	43	47	55	57	60	60	62	53	67
HMX 45 T6 (A5:6) (45°)	Inlet	42	46	54	58	61	62	63	55	68

Sound power Lw dB (A)										
Model		63 Hz	125 Hz	250 Hz	500 Hz	1000 Hz	2000 Hz	4000 Hz	8000 Hz	Total
HMX 50 T6 (A0:6) (35º)	Inlet	63	60	59	57	56	55	56	51	67
HMX 50 T6 (A0:6) (40º)	Inlet	66	63	61	59	59	57	59	54	70
HMX 50 T6 (A5:6) (25º)	Inlet	35	42	47	52	54	57	59	51	63
HMX 50 T6 (A5:6) (30º)	Inlet	38	43	50	54	57	58	61	52	65
HMX 50 T6 (A5:6) (35º)	Inlet	39	44	51	58	60	61	63	54	67
HMX 50 T6 (A5:6) (40º)	Inlet	40	47	52	58	60	61	63	54	67
HMX 50 T6 (A5:6) (45º)	Inlet	43	50	55	63	64	64	66	58	71
HMX 56 T6 (A5:6) (20º)	Inlet	63	70	75	76	77	75	73	65	82
HMX 56 T6 (A5:6) (25º)	Inlet	50	59	64	70	72	72	73	64	78
HMX 56 T6 (A5:6) (30º)	Inlet	58	68	75	77	78	76	74	66	83
HMX 56 T6 (A5:6) (35º)	Inlet	47	58	63	69	70	71	72	64	78
HMX 56 T6 (A5:6) (40º)	Inlet	53	66	76	81	81	75	73	64	85
HMX 56 T6 (A5:6) (45º)	Inlet	57	69	84	90	88	77	73	63	93
HMX 63 T6 (A5:6) (20º)	Inlet	66	73	78	79	80	77	76	69	85
HMX 63 T6 (A5:6) (25º)	Inlet	51	60	65	70	74	73	73	67	79
HMX 63 T6 (A5:6) (30º)	Inlet	54	62	72	79	77	76	76	69	83
HMX 63 T6 (A5:6) (35º)	Inlet	50	62	67	71	75	74	76	69	81
HMX 63 T6 (A5:6) (40º)	Inlet	51	63	74	86	83	78	76	68	88
HMX 63 T6 (A5:6) (45º)	Inlet	52	63	79	96	88	81	76	67	97
HMX 71 T6 (A5:6) (20º)	Inlet	68	75	80	82	82	80	79	72	88
HMX 71 T6 (A5:6) (25º)	Inlet	55	65	71	75	78	79	79	70	84
HMX 71 T6 (A5:6) (30º)	Inlet	57	65	71	77	78	78	77	68	84
HMX 71 T6 (A5:6) (35º)	Inlet	49	61	66	71	74	75	76	67	81
HMX 71 T6 (A5:6) (40º)	Inlet	54	64	79	89	85	80	78	68	91
HMX 71 T6 (A5:6) (45º)	Inlet	57	66	88	101	92	83	79	69	102
HMX 80 T6 (A5:6) (20º)	Inlet	71	78	83	85	85	83	82	75	91
HMX 80 T6 (A5:6) (25º)	Inlet	58	65	71	76	78	78	79	71	84
HMX 80 T6 (A5:6) (30º)	Inlet	58	69	76	86	84	82	82	74	90
HMX 80 T6 (A5:6) (35º)	Inlet	55	67	73	81	86	84	84	75	90
HMX 80 T6 (A5:6) (40º)	Inlet	56	69	85	90	87	83	81	73	93
HMX 80 T6 (A5:6) (45º)	Inlet	56	70	93	96	87	82	79	71	98
HMX 90 T6 (A6:3) (20º)	Inlet	77	70	72	68	70	70	73	69	81
HMX 90 T6 (A6:3) (22º)	Inlet	78	72	73	70	71	71	74	70	82
HMX 90 T6 (A6:3) (24º)	Inlet	79	73	74	72	73	73	75	71	84
HMX 90 T6 (A6:3) (26º)	Inlet	80	75	75	74	74	74	76	72	85
HMX 90 T6 (A6:3) (28º)	Inlet	81	76	76	76	75	75	77	73	86
HMX 90 T6 (A6:3) (30º)	Inlet	82	77	77	78	76	76	78	74	87
HMX 90 T6 (A6:3) (32º)	Inlet	82	78	78	79	77	77	78	74	87
HMX 90 T6 (A6:3) (34º)	Inlet	82	78	78	80	77	77	78	75	88

Sound power Lw dB (A)										
Model		63 Hz	125 Hz	250 Hz	500 Hz	1000 Hz	2000 Hz	4000 Hz	8000 Hz	Total
HMX 90 T6 (A6:3) (36°)	Inlet	82	79	79	81	78	78	79	75	88
HMX 90 T6 (A6:3) (38°)	Inlet	83	80	80	82	79	79	80	76	89
HMX 90 T6 (A6:3) (40°)	Inlet	83	81	81	83	80	81	81	77	90
HMX 90 T6 (A6:3) (42°)	Inlet	83	82	81	83	81	82	81	78	91
HMX 90 T6 (A6:6) (20°)	Inlet	82	81	80	82	83	80	80	78	90
HMX 90 T6 (A6:6) (22°)	Inlet	82	82	81	82	83	80	81	78	90
HMX 90 T6 (A6:6) (24°)	Inlet	83	83	82	83	83	81	82	79	91
HMX 90 T6 (A6:6) (26°)	Inlet	84	83	82	83	83	81	82	79	91
HMX 90 T6 (A6:6) (28°)	Inlet	85	84	82	84	83	81	83	80	92
HMX 90 T6 (A6:6) (30°)	Inlet	85	84	83	84	82	81	83	80	92
HMX 90 T6 (A6:6) (32°)	Inlet	84	83	81	82	80	80	82	78	91
HMX 90 T6 (A6:6) (34°)	Inlet	83	82	80	80	79	79	80	77	89
HMX 90 T6 (A6:6) (36°)	Inlet	83	81	79	80	78	78	80	76	89
HMX 90 T6 (A6:6) (38°)	Inlet	83	82	80	81	79	79	80	77	90
HMX 90 T6 (A6:6) (40°)	Inlet	84	83	81	81	79	79	81	77	90
HMX 90 T6 (A6:6) (42°)	Inlet	84	84	82	82	80	80	81	77	91
HMX 100 T6 (A6:3) (20°)	Inlet	81	78	76	75	77	78	81	76	87
HMX 100 T6 (A6:3) (22°)	Inlet	82	79	77	76	78	78	82	76	88
HMX 100 T6 (A6:3) (24°)	Inlet	82	79	77	77	78	78	81	76	88
HMX 100 T6 (A6:3) (26°)	Inlet	82	79	77	77	77	78	80	76	88
HMX 100 T6 (A6:3) (28°)	Inlet	82	79	77	77	77	77	79	75	87
HMX 100 T6 (A6:3) (30°)	Inlet	82	79	77	77	77	77	79	75	87
HMX 100 T6 (A6:3) (32°)	Inlet	84	80	79	79	78	78	79	76	89
HMX 100 T6 (A6:3) (34°)	Inlet	86	81	81	81	79	79	80	77	90
HMX 100 T6 (A6:3) (36°)	Inlet	86	82	82	82	80	80	80	77	91
HMX 100 T6 (A6:3) (38°)	Inlet	86	83	82	82	81	81	81	78	91
HMX 100 T6 (A6:3) (40°)	Inlet	86	83	82	83	82	81	82	79	92
HMX 100 T6 (A6:3) (42°)	Inlet	86	84	82	84	83	82	82	79	92
HMX 100 T6 (A6:6) (20°)	Inlet	85	86	84	89	87	85	85	83	95
HMX 100 T6 (A6:6) (22°)	Inlet	86	86	84	88	86	84	85	82	95
HMX 100 T6 (A6:6) (24°)	Inlet	86	86	85	88	86	84	85	82	95
HMX 100 T6 (A6:6) (26°)	Inlet	88	87	86	88	86	85	85	83	95
HMX 100 T6 (A6:6) (28°)	Inlet	89	88	87	88	86	85	86	83	96
HMX 100 T6 (A6:6) (30°)	Inlet	90	88	87	88	86	85	86	83	96
HMX 100 T6 (A6:6) (32°)	Inlet	89	87	86	86	84	84	85	82	95
HMX 100 T6 (A6:6) (34°)	Inlet	88	86	85	84	83	82	84	81	94
HMX 100 T6 (A6:6) (36°)	Inlet	88	86	85	83	82	82	83	80	93
HMX 100 T6 (A6:6) (38°)	Inlet	89	87	85	84	83	83	84	80	94
HMX 100 T6 (A6:6) (40°)	Inlet	89	87	86	85	84	84	85	81	95

Sound power Lw dB (A)										
Model		63 Hz	125 Hz	250 Hz	500 Hz	1000 Hz	2000 Hz	4000 Hz	8000 Hz	Total
HMX 100 T6 (A6:6) (42°)	Inlet	89	87	86	85	84	83	84	81	95
HMX 112 T6 (A6:3) (20°)	Inlet	84	81	79	80	82	82	84	81	91
HMX 112 T6 (A6:3) (22°)	Inlet	85	82	80	81	82	82	84	81	92
HMX 112 T6 (A6:3) (24°)	Inlet	86	83	81	82	83	83	85	82	93
HMX 112 T6 (A6:3) (26°)	Inlet	87	84	82	82	83	83	85	82	93
HMX 112 T6 (A6:3) (28°)	Inlet	88	84	83	83	83	83	85	82	93
HMX 112 T6 (A6:3) (30°)	Inlet	88	83	83	83	82	82	84	81	93
HMX 112 T6 (A6:3) (32°)	Inlet	89	84	84	83	82	82	84	81	93
HMX 112 T6 (A6:3) (34°)	Inlet	89	84	84	83	83	82	84	81	94
HMX 112 T6 (A6:3) (36°)	Inlet	89	84	85	84	83	82	84	81	94
HMX 112 T6 (A6:3) (38°)	Inlet	90	85	85	84	83	83	84	82	94
HMX 112 T6 (A6:3) (40°)	Inlet	89	85	84	85	84	83	84	81	94
HMX 112 T6 (A6:3) (42°)	Inlet	89	86	84	85	84	84	84	82	95
HMX 112 T6 (A6:6) (20°)	Inlet	86	87	85	91	89	86	88	85	96
HMX 112 T6 (A6:6) (22°)	Inlet	87	87	86	90	88	86	87	84	96
HMX 112 T6 (A6:6) (24°)	Inlet	87	87	85	89	87	86	87	83	96
HMX 112 T6 (A6:6) (26°)	Inlet	89	88	86	89	87	86	87	83	96
HMX 112 T6 (A6:6) (28°)	Inlet	91	88	86	89	87	87	88	83	97
HMX 112 T6 (A6:6) (30°)	Inlet	91	88	86	88	87	87	87	83	97
HMX 112 T6 (A6:6) (32°)	Inlet	91	88	86	86	85	86	87	82	96
HMX 112 T6 (A6:6) (34°)	Inlet	91	88	86	84	84	85	86	81	95
HMX 112 T6 (A6:6) (36°)	Inlet	91	88	86	84	85	85	86	81	96
HMX 112 T6 (A6:6) (38°)	Inlet	93	90	88	86	86	86	87	82	97
HMX 112 T6 (A6:6) (40°)	Inlet	95	91	90	88	88	88	88	84	99
HMX 112 T6 (A6:6) (42°)	Inlet	95	91	90	88	87	87	88	83	99
HMX 125 T6 (A7:4) (20°)	Inlet	88	92	90	91	92	91	93	92	101
HMX 125 T6 (A7:4) (22°)	Inlet	91	93	91	92	92	92	94	92	102
HMX 125 T6 (A7:4) (24°)	Inlet	92	91	89	90	90	90	92	90	100
HMX 125 T6 (A7:4) (26°)	Inlet	92	90	88	88	88	89	90	87	98
HMX 125 T6 (A7:4) (28°)	Inlet	92	89	87	86	87	87	88	85	97
HMX 125 T6 (A7:4) (30°)	Inlet	90	87	85	84	85	85	86	82	95
HMX 125 T6 (A7:4) (32°)	Inlet	90	87	85	84	84	85	86	81	95
HMX 125 T6 (A7:4) (34°)	Inlet	90	87	85	83	84	84	85	80	95
HMX 125 T6 (A7:4) (36°)	Inlet	90	87	85	84	84	85	85	80	95
HMX 125 T6 (A7:4) (38°)	Inlet	91	88	86	85	85	86	86	81	96
HMX 125 T6 (A7:4) (40°)	Inlet	92	89	87	85	85	86	86	81	96
HMX 125 T6 (A7:4) (42°)	Inlet	92	89	87	86	85	87	86	82	97
HMX 125 T6 (A7:8) (20°)	Inlet	94	92	91	94	98	99	98	95	106
HMX 125 T6 (A7:8) (22°)	Inlet	94	92	91	93	96	98	98	94	105

Sound power Lw dB (A)										
Model		63 Hz	125 Hz	250 Hz	500 Hz	1000 Hz	2000 Hz	4000 Hz	8000 Hz	Total
HMX 125 T6 (A7:8) (24°)	Inlet	94	91	90	92	95	96	96	92	103
HMX 125 T6 (A7:8) (26°)	Inlet	94	90	90	91	94	95	95	91	102
HMX 125 T6 (A7:8) (28°)	Inlet	94	90	89	90	92	94	94	90	102
HMX 125 T6 (A7:8) (30°)	Inlet	93	89	89	88	91	92	92	88	100
HMX 125 T6 (A7:8) (32°)	Inlet	94	89	89	88	89	91	91	86	99
HMX 125 T6 (A7:8) (34°)	Inlet	94	90	89	88	88	89	89	84	99
HMX 125 T6 (A7:8) (36°)	Inlet	94	91	89	88	88	89	88	83	99
HMX 125 T6 (A7:8) (38°)	Inlet	94	91	89	88	88	89	88	83	99
HMX 125 T6 (A7:8) (40°)	Inlet	94	91	89	87	87	88	87	83	98
HMX 125 T6 (A7:8) (42°)	Inlet	93	90	88	87	87	88	86	82	98