

MBGR



MEDIUM PRESSURE FAN WITH BACKWARD IMPELLER

MANUFACTURING FEATURES:

- Fan made of Fe360 sheet. The fan paint finish is based on a Qualicoat polyester powder coating stoved at 200°C, with an average film thickness of 70 microns. Average heat resistance of coating is 180°C with peaks of 200°C.
- Fully welded housing.
- Single inlet backward curved impeller made of Fe360 sheet statically and dynamically balanced. Impellers are painted with epoxy primer that resists temperatures up to 300°C.
- Standard asynchronous squirrel-cage motor with IP-55 protection and class F insulation. Manufactured with standard voltages: 230V/400V 50Hz in single phase motors and 230/400V 50Hz in three phase motors up to 4kW and 400/690V 50Hz for higher powers.
- Standard orientation LG270.
- It allows adjusting the orientation locally from models 400 to 630. Models sizes from 710 to 1400 size the orientation is fixed.

APPLICATIONS:

- Designed for inline installation, they are suitable for:
- Industrial applications, extraction or injection of air.
 - Cooling of machines and parts.
 - Clean and slightly dusty air transport.
 - Exhaust after filters, separators and cyclones.
 - Pneumatic transport.
 - Maximum working temperature: carried air: 130°C, ambient: 60°C.

UNDER REQUEST:

- 60Hz fans and special voltages.
- 2 speed motors.
- Spark-proof fans with ATEX certified motor.
- Fan for air working temperatures up to 250°C with R/R (cooling impeller).
- Hot dip galvanised or stainless steel fans.
- Orientation: RD0, RD45, RD90, RD135, RD180, RD225, RD270, RD315, LG0, LG45, LG90, LG135, LG180, LG225, LG315.

Accessories



AC



BAD



EI



INT



JE-45



RA



RI



SFC

Technical data

Three-phase motor / 2 poles

Code	Model	R.P.M.	Rated I. (A) 400V	Rated power kW	Max. Airflow m3/h	Sound db (A)*	Weight	Connect. diagram
502004027	MBGR 401 T2 2,2kW	2800	4,58	2,20	2.880	56	73	1
502004029	MBGR 402 T2 3kW	2870	5,92	3	3.600	59	81	1
502004532	MBGR 451 T2 4kW	2890	7,63	4	4.320	62	107	1
502004534	MBGR 452 T2 5,5kW	2900	10,6	5,50	5.400	66	136	1
502005036	MBGR 501 T2 7,5kW	2900	14,1	7,50	7.200	71	145	1
502005021	MBGR 502 T2 11kW	2930	20,8	11	8.640	72	210	1
502005621	MBGR 561 T2 11kW	2930	20,8	11	8.640	70	227	1
502005624	MBGR 562 T2 15kW	2930	27,4	15	12.600	74	240	1
502006328	MBGR 631 T2 22kW	2940	39,8	22	14.400	77	315	1
502006330	MBGR 632 T2 30kW	2950	56,6	30	18.000	78	400	1
502007131	MBGR 711 T2 37kW	2955	66,7	37	19.800	81	492	1
502007133	MBGR 712 T2 45kW	2960	78	45	21.600	82	602	1
502008037	MBGR 801 T2 75kW	2965	130	75	28.800	84	800	1
502008038	MBGR 802 T2 90kW	2970	156	90	36.000	85	860	1
502009023	MBGR 901 T2 132kW	2980	223	132	36.000	89	1.065	1
502009025	MBGR 902 T2 160kW	2980	269	160	46.800	92	1.090	1

Three-phase motor / 4 poles

Code	Model	R.P.M.	Rated I. (A) 400V	Rated power kW	Max. Airflow m3/h	Sound db (A)*	Weight	Connect. diagram
502005646	MBGR 563 T4 1,5kW	1400	3,26	1,50	4.680	53	165	1
502005654	MBGR 564 T4 2,2kW	1430	4,64	2,20	5.400	56	169	1
502006356	MBGR 633 T4 3kW	1430	6,17	3	6.120	58	180	1
502006359	MBGR 634 T4 4kW	1440	8,32	4	7.920	59	190	1
502007159	MBGR 713 T4 4kW	1440	8,32	4	9.360	62	249	1
502007161	MBGR 714 T4 5,5kW	1440	10,5	5,50	10.800	65	272	1
502008063	MBGR 803 T4 7,5kW	1440	14,1	7,50	10.800	65	370	1
502008049	MBGR 804 T4 11kW	1460	21,2	11	18.000	69	415	1
502009052	MBGR 903 T4 15kW	1460	29,8	15	19.800	67	495	1
502009055	MBGR 904 T4 22kW	1470	40,1	22	25.200	73	576	1
502010057	MBGR 1001 T4 30kW	1475	56,3	30	28.800	75	794	1
502010058	MBGR 1002 T4 37kW	1475	69,2	37	36.000	77	893	1
502011260	MBGR 1121 T4 45kW	1475	80,7	45	36.000	79	1.032	1
502011262	MBGR 1122 T4 55kW	1480	97,1	55	46.800	80	1.132	1

Code	Model	R.P.M.	Rated I. (A) 400V	Rated power kW	Max. Airflow m3/h	Sound db (A)*	Weight	Connect. diagram
502012564	MBGR 1251 T4 75kW	1480	133	75	54.000	83	1.442	1
502012550	MBGR 1252 T4 110kW	1485	194	110	72.000	85	1.770	1
502014051	MBGR 1401 T4 132kW	1485	230	132	72.000	86	2.150	1
502014104	MBGR 1402 T4 160kW	1489	278	160	90.000	84	2.170	1

Three-phase motor / 6 poles

Code	Model	R.P.M.	Rated I. (A) 400V	Rated power kW	Max. Airflow m3/h	Sound db (A)*	Weight	Connect. diagram
502009083	MBGR 905 T6 4kW	960	9,46	4	10.800	55	441	1
502009085	MBGR 906 T6 5,5kW	960	12,8	5,50	14.400	57	450	1
502010087	MBGR 1003 T6 7,5kW	965	15,2	7,50	18.000	62	613	1
502010075	MBGR 1004 T6 11kW	970	22,6	11	21.600	67	626	1
502011276	MBGR 1123 T6 15kW	970	27,7	15	25.200	67	836	1
502011277	MBGR 1124 T6 18,5kW	975	35,7	18,50	32.400	68	861	1
502012579	MBGR 1253 T6 22kW	975	42,3	22	36.000	71	900	1
502012581	MBGR 1254 T6 30kW	980	54,4	30	46.800	73	1.287	1
502014082	MBGR 1403 T6 37kW	980	66,8	37	46.800	76	1.819	1
502014086	MBGR 1404 T6 55kW	980	102	55	61.000	76	2.058	1

Notes:

* Total sound pressure level at the point of maximum flow measured in dB(A) in the suction measured in free field at a distance of 6m from the source

Dimensions

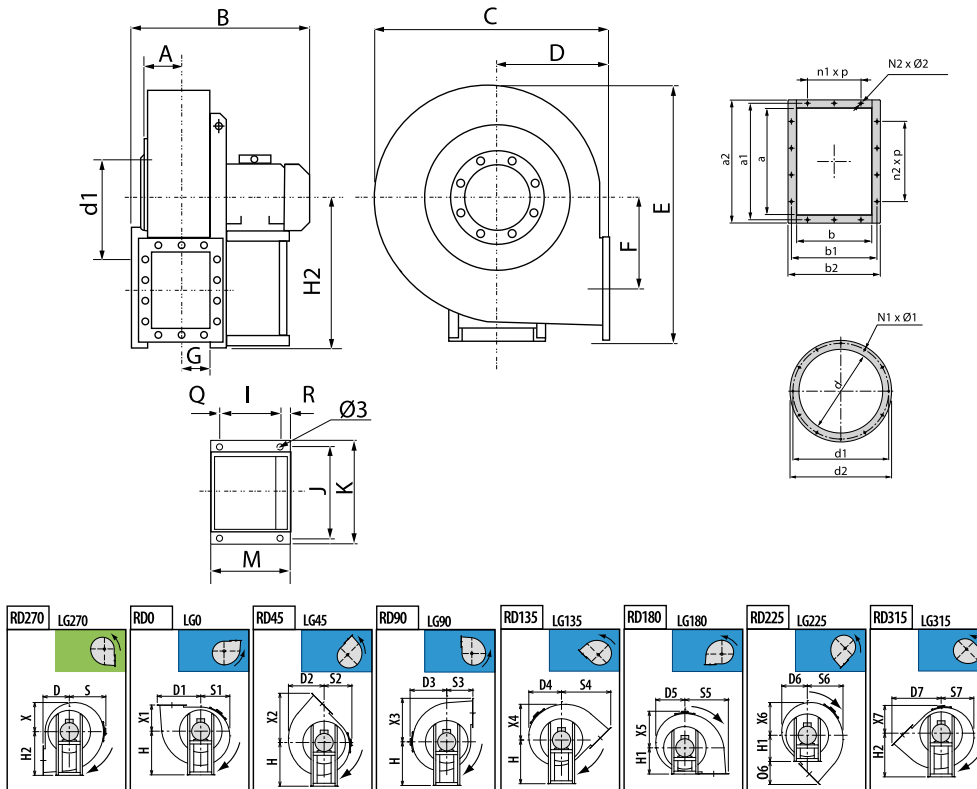

Model	A	B	C	D	D1	D2	D3	D4	D5
MBGR 401 T2 2,2kW	105	511	685	285	483	387	400	353	315
MBGR 402 T2 3kW	105	560	655	285	483	387	400	353	315
MBGR 451 T2 4kW	115	585	735	320	541	435	445	398	354
MBGR 452 T2 5,5kW	115	647	735	320	541	435	445	398	354
MBGR 501 T2 7,5kW	127	671	832	360	597	490	502	450	400
MBGR 502 T2 11kW	127	807	832	360	597	490	502	450	400

Model	D6	D7	E	F	G	H	H1	H2	I
MBGR 401 T2 2,2kW	306	543	815	319	95	500	285	500	133
MBGR 402 T2 3kW	306	543	815	319	95	500	285	500	197
MBGR 451 T2 4kW	342	609	915	357	106	560	320	560	197
MBGR 452 T2 5,5kW	342	609	915	357	106	560	320	560	237
MBGR 501 T2 7,5kW	380	676	1000	396	118	600	360	600	237
MBGR 502 T2 11kW	380	676	1000	396	118	600	360	600	337

Model	J	K	M	N1xØ1	N2xØ2	O6	Q	R	S
MBGR 401 T2 2,2kW	234	260	246	8x10	10x12	258	55	58	400
MBGR 402 T2 3kW	289	324	276	8x10	10x12	258	30	49	400

Model	J	K	M	N1xØ1	N2xØ2	O6	Q	R	S
MBGR 451 T2 4kW	289	324	276	8x12	10x12	289	30	49	445
MBGR 452 T2 5,5kW	337	372	336	8x12	10x12	289	40	59	445
MBGR 501 T2 7,5kW	337	372	336	8x12	10x12	316	40	59	502
MBGR 502 T2 11kW	395	440	436	8x12	10x12	316	50	49	502

Model	S1	S2	S3	S4	S5	S6	S7	X	X1
MBGR 401 T2 2,2kW	315	306	285	543	483	387	353	315	285
MBGR 402 T2 3kW	315	306	285	543	483	387	353	315	285
MBGR 451 T2 4kW	354	342	320	609	541	435	398	354	320
MBGR 452 T2 5,5kW	354	342	320	609	541	435	398	354	320
MBGR 501 T2 7,5kW	400	380	360	676	597	490	450	400	360
MBGR 502 T2 11kW	400	380	360	676	597	490	450	400	360

Model	X2	X3	X4	X5	X6	X7	a	a1	a2
MBGR 401 T2 2,2kW	543	483	387	400	353	306	258	292	328
MBGR 402 T2 3kW	543	483	387	400	353	306	258	292	328
MBGR 451 T2 4kW	609	541	435	445	398	342	288	332	368
MBGR 452 T2 5,5kW	609	541	435	445	398	342	288	332	368
MBGR 501 T2 7,5kW	676	597	490	502	450	380	322	366	402
MBGR 502 T2 11kW	676	597	490	502	450	380	322	366	402

Model	b	b1	b2	d	d1	d2	n1xp	n2xp	Ø3
MBGR 401 T2 2,2kW	185	219	255	255	292	325	1x112	2x112	12
MBGR 402 T2 3kW	185	219	255	255	292	325	1x112	2x112	12
MBGR 451 T2 4kW	205	249	285	285	332	365	1x125	2x125	12
MBGR 452 T2 5,5kW	205	249	285	285	332	365	1x125	2x125	12
MBGR 501 T2 7,5kW	229	273	309	320	366	400	1x125	2x125	12
MBGR 502 T2 11kW	229	273	309	320	366	400	1x125	2x125	12

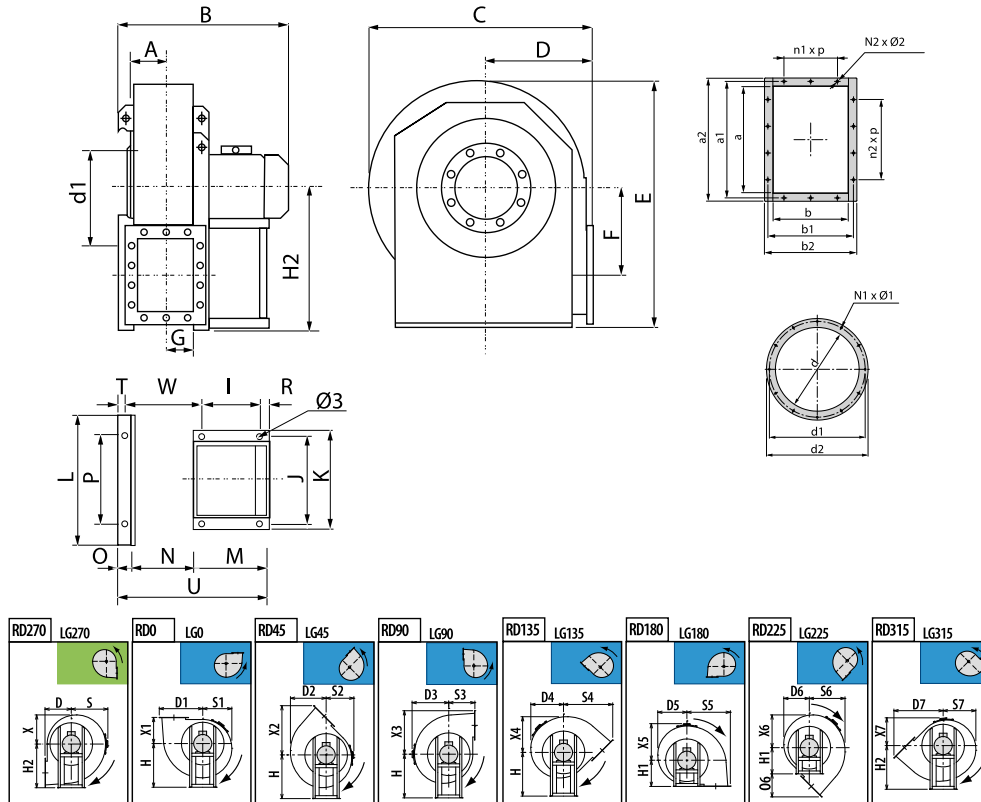

Model	A	B	C	D	D1	D2	D3	D4	D5
MBGR 561 T2 11kW	142	847	940	400	657	555	570	542	485
MBGR 562 T2 15kW	142	847	940	400	657	555	570	542	485
MBGR 563 T4 1,5kW	142	579	940	400	657	555	570	542	485
MBGR 564 T4 2,2kW	142	649	940	400	657	555	570	542	485
MBGR 631 T2 22kW	158	954	1052	450	732	619	630	603	540
MBGR 632 T2 30kW	158	954	1052	450	732	619	630	603	540
MBGR 633 T4 3kW	158	681	1052	450	732	619	630	603	540
MBGR 634 T4 4kW	158	681	1052	450	732	619	630	603	540

Model	D6	D7	E	F	G	H	H1	H2	I
MBGR 561 T2 11kW	425	747	1126	436	132	670	400	670	337
MBGR 562 T2 15kW	425	747	1126	436	132	670	400	670	337
MBGR 563 T4 1,5kW	425	747	1126	436	132	670	400	670	133
MBGR 564 T4 2,2kW	425	747	1126	436	132	670	400	670	197
MBGR 631 T2 22kW	476	836	1260	490	148	750	450	750	357
MBGR 632 T2 30kW	476	836	1260	490	148	750	450	750	381
MBGR 633 T4 3kW	476	836	1260	490	148	750	450	750	197
MBGR 634 T4 4kW	476	836	1260	490	148	750	450	750	197

Model	J	K	L	M	N	N1xØ1	N2xØ2	O	O6
-------	---	---	---	---	---	-------	-------	---	----

Model	J	K	L	M	N	N1xØ1	N2xØ2	O	O6
MBGR 561 T2 11kW	395	440	692	436	260	8x12	10x12	53	347
MBGR 562 T2 15kW	395	440	692	436	260	8x12	10x12	53	347
MBGR 563 T4 1,5kW	234	260	692	246	260	8x12	10x12	53	347
MBGR 564 T4 2,2kW	289	324	692	276	260	8x12	10x12	53	347
MBGR 631 T2 22kW	434	488	762	460	292	12x12	14x12	53	386
MBGR 632 T2 30kW	506	568	762	500	292	12x12	14x12	53	386
MBGR 633 T4 3kW	289	324	762	276	292	12x12	14x12	53	386
MBGR 634 T4 4kW	289	324	762	276	292	12x12	14x12	53	386

Model	P	R	S	S1	S2	S3	S4	S5	S6
MBGR 561 T2 11kW	632	49	570	485	425	400	747	657	555
MBGR 562 T2 15kW	632	49	570	485	425	400	747	657	555
MBGR 563 T4 1,5kW	632	58	570	485	425	400	747	657	555
MBGR 564 T4 2,2kW	632	49	570	485	425	400	747	657	555
MBGR 631 T2 22kW	702	33	630	540	476	450	836	732	619
MBGR 632 T2 30kW	702	39	630	540	476	450	836	732	619
MBGR 633 T4 3kW	702	49	630	540	476	450	836	732	619
MBGR 634 T4 4kW	702	49	630	540	476	450	836	732	619

Model	S7	T	U	W	X	X1	X2	X3	X4
MBGR 561 T2 11kW	542	23	750	340	485	400	747	657	555
MBGR 562 T2 15kW	542	23	750	340	485	400	747	657	555
MBGR 563 T4 1,5kW	542	23	564	345	485	400	747	657	555
MBGR 564 T4 2,2kW	542	23	590	320	485	400	747	657	555
MBGR 631 T2 22kW	603	23	805	392	540	450	836	732	619
MBGR 632 T2 30kW	603	23	845	402	540	450	836	732	619
MBGR 633 T4 3kW	603	23	621	352	540	450	836	732	619
MBGR 634 T4 4kW	603	23	621	352	540	450	836	732	619

Model	X5	X6	X7	a	a1	a2	b	b1	b2
MBGR 561 T2 11kW	570	542	425	361	405	441	256	300	336
MBGR 562 T2 15kW	570	542	425	361	405	441	256	300	336
MBGR 563 T4 1,5kW	570	542	425	361	405	441	256	300	336
MBGR 564 T4 2,2kW	570	542	425	361	405	441	256	300	336
MBGR 631 T2 22kW	630	603	476	404	448	484	288	332	368
MBGR 632 T2 30kW	630	603	476	404	448	484	288	332	368
MBGR 633 T4 3kW	630	603	476	404	448	484	288	332	368
MBGR 634 T4 4kW	630	603	476	404	448	484	288	332	368

Model	d	d1	d2	n1xp	n2xp	Ø3
-------	---	----	----	------	------	----

Model	d	d1	d2	n1xp	n2xp	Ø3
MBGR 561 T2 11kW	360	405	440	1x125	2x125	14
MBGR 562 T2 15kW	360	405	440	1x125	2x125	14
MBGR 563 T4 1,5kW	360	405	440	1x125	2x125	10
MBGR 564 T4 2,2kW	360	405	440	1x125	2x125	12
MBGR 631 T2 22kW	405	448	485	2x125	3x125	18
MBGR 632 T2 30kW	405	448	485	2x125	3x125	20
MBGR 633 T4 3kW	405	448	485	2x125	3x125	12
MBGR 634 T4 4kW	405	448	485	2x125	3x125	12

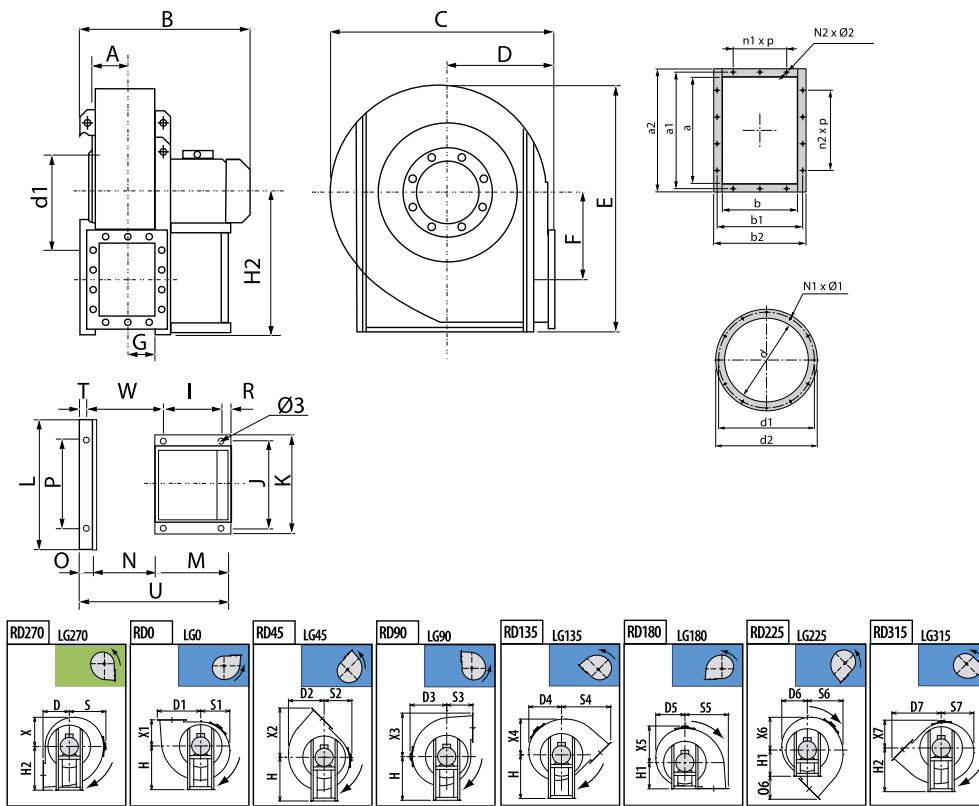

Model	A	B	C	D	D1	D2	D3	D4	D5
MBGR 711 T2 37kW	185	995	1189	500	825	719	690	662	596
MBGR 712 T2 45kW	185	1072	1189	500	825	719	690	662	596
MBGR 713 T4 4kW	185	772	1189	500	825	719	690	662	596
MBGR 714 T4 5,5kW	185	784	1189	500	825	719	690	662	596
MBGR 801 T2 75kW	199	1260	1340	560	919	811	782	749	672
MBGR 802 T2 90kW	199	1260	1340	560	919	811	782	749	672
MBGR 803 T4 7,5kW	199	842	1340	560	919	811	782	749	672
MBGR 804 T4 11kW	199	978	1340	560	919	811	782	749	672

Model	A	B	C	D	D1	D2	D3	D4	D5
MBGR 901 T2 132kW	221	1446	1500	630	1038	905	870	835	721
MBGR 902 T2 160kW	221	1446	1500	630	1038	905	870	835	721
MBGR 903 T4 15kW	221	1022	1500	630	1038	905	870	835	721
MBGR 904 T4 22kW	221	1097	1500	630	1038	905	870	835	721
MBGR 905 T6 4kW	221	886	1500	630	1038	905	870	835	721
MBGR 906 T6 5,5kW	221	886	1500	630	1038	905	870	835	721
MBGR 1001 T4 30kW	246	1165	1685	710	1160	1015	976	936	813
MBGR 1002 T4 37kW	246	1242	1685	710	1160	1015	976	936	813
MBGR 1003 T6 7,5kW	246	1090	1685	710	1160	1015	976	936	813
MBGR 1004 T6 11kW	246	1090	1685	710	1160	1015	976	936	813
MBGR 1121 T4 45kW	277	1296	1884	800	1300	1123	1084	1037	932
MBGR 1122 T4 55kW	277	1296	1884	800	1300	1123	1084	1037	932
MBGR 1123 T6 15kW	277	1219	1884	800	1300	1123	1084	1037	932
MBGR 1124 T6 18,5kW	277	1219	1884	800	1300	1123	1084	1037	932
MBGR 1251 T4 75kW	310	1489	2116	900	1464	1270	1214	1163	1048
MBGR 1252 T4 110kW	310	1489	2116	900	1464	1270	1214	1163	1048
MBGR 1253 T6 22kW	310	1282	2116	900	1464	1270	1214	1163	1048
MBGR 1254 T6 30kW	310	1359	2116	900	1464	1270	1214	1163	1048
MBGR 1401 T4 132kW	344	1730	2325	1000	1625	1395	1325	1272	1145
MBGR 1402 T4 160kW	344	1730	2325	1000	1625	1395	1325	1272	1145
MBGR 1403 T6 37kW	344	1458	2325	1000	1625	1395	1325	1272	1145
MBGR 1404 T6 55kW	344	1558	2325	1000	1625	1395	1325	1272	1145

Model	D6	D7	E	F	G	H	H1	H2	I
MBGR 711 T2 37kW	497	937	1416	558	161	670	500	850	401
MBGR 712 T2 45kW	497	937	1416	558	161	670	500	850	440
MBGR 713 T4 4kW	497	937	1416	558	161	670	500	850	151
MBGR 714 T4 5,5kW	497	937	1416	558	161	670	500	850	201
MBGR 801 T2 75kW	562	1045	1591	625	180	755	560	950	591
MBGR 802 T2 90kW	562	1045	1591	625	180	755	560	950	591
MBGR 803 T4 7,5kW	562	1045	1591	625	180	755	560	950	201
MBGR 804 T4 11kW	562	1045	1591	625	180	755	560	950	316
MBGR 901 T2 132kW	633	1179	1780	703	202	850	630	1060	701
MBGR 902 T2 160kW	633	1179	1780	703	202	850	630	1060	701
MBGR 903 T4 15kW	633	1179	1780	703	202	850	630	1060	316
MBGR 904 T4 22kW	633	1179	1780	703	202	850	630	1060	361
MBGR 905 T6 4kW	633	1179	1780	703	202	850	630	1060	201
MBGR 906 T6 5,5kW	633	1179	1780	703	202	850	630	1060	201
MBGR 1001 T4 30kW	718	1322	1993	791	226	950	710	1180	400
MBGR 1002 T4 37kW	718	1322	1993	791	226	950	710	1180	440

Model	D6	D7	E	F	G	H	H1	H2	I
MBGR 1003 T6 7,5kW	718	1322	1993	791	226	950	710	1180	315
MBGR 1004 T6 11kW	718	1322	1993	791	226	950	710	1180	315
MBGR 1121 T4 45kW	793	1487	2222	891	253	1060	800	1320	415
MBGR 1122 T4 55kW	793	1487	2222	891	253	1060	800	1320	475
MBGR 1123 T6 15kW	793	1487	2222	891	253	1060	800	1320	335
MBGR 1124 T6 18,5kW	793	1487	2222	891	253	1060	800	1320	375
MBGR 1251 T4 75kW	898	1671	2517	1003	284	1190	900	1500	565
MBGR 1252 T4 110kW	898	1671	2517	1003	284	1190	900	1500	675
MBGR 1253 T6 22kW	898	1671	2517	1003	284	1190	900	1500	375
MBGR 1254 T6 30kW	898	1671	2517	1003	284	1190	900	1500	415
MBGR 1401 T4 132kW	990	1856	2816	1116	319	1320	1000	1700	645
MBGR 1402 T4 160kW	990	1856	2816	1116	319	1320	1000	1700	645
MBGR 1403 T6 37kW	990	1856	2816	1116	319	1320	1000	1700	475
MBGR 1404 T6 55kW	990	1856	2816	1116	319	1320	1000	1700	535

Model	J	K	L	M	N	N1xØ1	N2xØ2	O	O6
MBGR 711 T2 37kW	772	826	914	500	322	12x12	14x12	60	437
MBGR 712 T2 45kW	772	826	914	540	322	12x12	14x12	60	437
MBGR 713 T4 4kW	772	826	914	276	322	12x12	14x12	60	437
MBGR 714 T4 5,5kW	772	826	914	336	322	12x12	14x12	60	437
MBGR 801 T2 75kW	862	926	1044	690	361	12x14	14x12	80	485
MBGR 802 T2 90kW	862	926	1044	690	361	12x14	14x12	80	485
MBGR 803 T4 7,5kW	862	926	1044	336	361	12x14	14x12	80	485
MBGR 804 T4 11kW	862	926	1044	436	361	12x14	14x12	80	485
MBGR 901 T2 132kW	962	1026	1144	800	404	12x14	14x14	80	549
MBGR 902 T2 160kW	962	1026	1144	800	404	12x14	14x14	80	549
MBGR 903 T4 15kW	962	1026	1144	436	404	12x14	14x14	80	549
MBGR 904 T4 22kW	962	1026	1144	460	404	12x14	14x14	80	549
MBGR 905 T6 4kW	962	1026	1144	336	404	12x14	14x14	80	549
MBGR 906 T6 5,5kW	962	1026	1144	336	404	12x14	14x14	80	549
MBGR 1001 T4 30kW	1056	1128	1254	500	453	12x14	14x14	100	612
MBGR 1002 T4 37kW	1056	1128	1254	540	453	12x14	14x14	100	612
MBGR 1003 T6 7,5kW	1056	1128	1254	436	453	12x14	14x14	100	612
MBGR 1004 T6 11kW	1056	1128	1254	436	453	12x14	14x14	100	612
MBGR 1121 T4 45kW	1178	1268	1400	540	507	16x14	16x14	100	687
MBGR 1122 T4 55kW	1178	1268	1400	600	507	16x14	16x14	100	687
MBGR 1123 T6 15kW	1178	1268	1400	460	507	16x14	16x14	100	687
MBGR 1124 T6 18,5kW	1178	1268	1400	500	507	16x14	16x14	100	687
MBGR 1251 T4 75kW	1310	1400	1530	690	569	16x14	14x14	100	771
MBGR 1252 T4 110kW	1310	1400	1530	800	569	16x14	14x14	100	771

Model	J	K	L	M	N	N1xØ1	N2xØ2	O	O6
MBGR 1253 T6 22kW	1310	1400	1530	500	569	16x14	14x14	100	771
MBGR 1254 T6 30kW	1310	1400	1530	540	569	16x14	14x14	100	771
MBGR 1401 T4 132kW	1450	1560	1690	800	638	16x14	18x14	130	856
MBGR 1402 T4 160kW	1450	1560	1690	800	638	16x14	18x14	130	856
MBGR 1403 T6 37kW	1450	1560	1690	600	638	16x14	18x14	130	856
MBGR 1404 T6 55kW	1450	1560	1690	690	638	16x14	18x14	130	856

Model	P	R	S	S1	S2	S3	S4	S5	S6
MBGR 711 T2 37kW	772	39	690	596	497	500	937	825	719
MBGR 712 T2 45kW	772	39	690	596	497	500	937	825	719
MBGR 713 T4 4kW	772	65	690	596	497	500	937	825	719
MBGR 714 T4 5,5kW	772	75	690	596	497	500	937	825	719
MBGR 801 T2 75kW	862	39	782	672	562	560	1045	919	811
MBGR 802 T2 90kW	862	39	782	672	562	560	1045	919	811
MBGR 803 T4 7,5kW	862	75	782	672	562	560	1045	919	811
MBGR 804 T4 11kW	862	60	782	672	562	560	1045	919	811
MBGR 901 T2 132kW	962	39	870	721	633	630	1179	1038	905
MBGR 902 T2 160kW	962	39	870	721	633	630	1179	1038	905
MBGR 903 T4 15kW	962	60	870	721	633	630	1179	1038	905
MBGR 904 T4 22kW	962	39	870	721	633	630	1179	1038	905
MBGR 905 T6 4kW	962	75	870	721	633	630	1179	1038	905
MBGR 906 T6 5,5kW	962	75	870	721	633	630	1179	1038	905
MBGR 1001 T4 30kW	1056	45	976	813	718	710	1322	1160	1015
MBGR 1002 T4 37kW	1056	45	976	813	718	710	1322	1160	1015
MBGR 1003 T6 7,5kW	1056	66	976	813	718	710	1322	1160	1015
MBGR 1004 T6 11kW	1056	66	976	813	718	710	1322	1160	1015
MBGR 1121 T4 45kW	1178	45	1084	932	793	800	1487	1300	1123
MBGR 1122 T4 55kW	1178	45	1084	932	793	800	1487	1300	1123
MBGR 1123 T6 15kW	1178	45	1084	932	793	800	1487	1300	1123
MBGR 1124 T6 18,5kW	1178	45	1084	932	793	800	1487	1300	1123
MBGR 1251 T4 75kW	1310	45	1214	1048	898	900	1671	1464	1270
MBGR 1252 T4 110kW	1310	45	1214	1048	898	900	1671	1464	1270
MBGR 1253 T6 22kW	1310	45	1214	1048	898	900	1671	1464	1270
MBGR 1254 T6 30kW	1310	45	1214	1048	898	900	1671	1464	1270
MBGR 1401 T4 132kW	1450	55	1325	1145	990	1000	1856	1625	1395
MBGR 1402 T4 160kW	1450	55	1325	1145	990	1000	1856	1625	1395
MBGR 1403 T6 37kW	1450	55	1325	1145	990	1000	1856	1625	1395
MBGR 1404 T6 55kW	1450	55	1325	1145	990	1000	1856	1625	1395

Model	S7	T	U	W	X	X1	X2	X3	X4
-------	----	---	---	---	---	----	----	----	----

Model	S7	T	U	W	X	X1	X2	X3	X4
MBGR 711 T2 37kW	662	27	882	415	596	500	937	825	719
MBGR 712 T2 45kW	662	27	992	415	596	500	937	825	719
MBGR 713 T4 4kW	662	27	658	415	596	500	937	825	719
MBGR 714 T4 5,5kW	662	27	682	415	596	500	937	825	719
MBGR 801 T2 75kW	749	47	1131	454	672	560	1045	919	811
MBGR 802 T2 90kW	749	47	1131	454	672	560	1045	919	811
MBGR 803 T4 7,5kW	749	47	778	454	672	560	1045	919	811
MBGR 804 T4 11kW	749	47	878	454	672	560	1045	919	811
MBGR 901 T2 132kW	835	47	1284	497	721	630	1179	1038	905
MBGR 902 T2 160kW	835	47	1284	497	721	630	1179	1038	905
MBGR 903 T4 15kW	835	47	920	497	721	630	1179	1038	905
MBGR 904 T4 22kW	835	47	944	497	721	630	1179	1038	905
MBGR 905 T6 4kW	835	47	820	497	721	630	1179	1038	905
MBGR 906 T6 5,5kW	835	47	820	497	721	630	1179	1038	905
MBGR 1001 T4 30kW	936	67	1053	541	813	710	1322	1160	1015
MBGR 1002 T4 37kW	936	67	1093	541	813	710	1322	1160	1015
MBGR 1003 T6 7,5kW	936	67	990	541	813	710	1322	1160	1015
MBGR 1004 T6 11kW	936	67	990	541	813	710	1322	1160	1015
MBGR 1121 T4 45kW	1037	55	1147	632	932	800	1487	1300	1123
MBGR 1122 T4 55kW	1037	55	1207	632	932	800	1487	1300	1123
MBGR 1123 T6 15kW	1037	55	1067	632	932	800	1487	1300	1123
MBGR 1124 T6 18,5kW	1037	5	1107	632	932	800	1487	1300	1123
MBGR 1251 T4 75kW	1163	55	1359	694	1048	900	1671	1464	1270
MBGR 1252 T4 110kW	1163	55	1469	694	1048	900	1671	1464	1270
MBGR 1253 T6 22kW	1163	55	1169	694	1048	900	1671	1464	1270
MBGR 1254 T6 30kW	1163	55	1209	694	1048	900	1671	1464	1270
MBGR 1401 T4 132kW	1272	85	1568	783	1145	1000	1856	1625	1395
MBGR 1402 T4 160kW	1272	85	1568	783	1145	1000	1856	1625	1395
MBGR 1403 T6 37kW	1272	85	1368	753	1145	1000	1856	1625	1395
MBGR 1404 T6 55kW	1272	85	1458	783	1145	1000	1856	1625	1395

Model	X5	X6	X7	a	a1	a2	b	b1	b2
MBGR 711 T2 37kW	690	662	497	453	497	533	322	366	402
MBGR 712 T2 45kW	690	662	497	453	497	533	322	366	402
MBGR 713 T4 4kW	690	662	497	453	497	533	322	366	402
MBGR 714 T4 5,5kW	690	662	497	453	497	533	322	366	402
MBGR 801 T2 75kW	782	749	562	507	551	587	361	405	441
MBGR 802 T2 90kW	782	749	562	507	551	587	361	405	441
MBGR 803 T4 7,5kW	782	749	562	507	551	587	361	405	441
MBGR 804 T4 11kW	782	749	562	507	551	587	361	405	441

Model	X5	X6	X7	a	a1	a2	b	b1	b2
MBGR 901 T2 132kW	870	835	633	569	629	669	404	464	504
MBGR 902 T2 160kW	870	835	633	569	629	669	404	464	504
MBGR 903 T4 15kW	870	835	633	569	629	669	404	464	504
MBGR 904 T4 22kW	870	835	633	569	629	669	404	464	504
MBGR 905 T6 4kW	870	835	633	569	629	669	404	464	504
MBGR 906 T6 5,5kW	870	835	633	569	629	669	404	464	504
MBGR 1001 T4 30kW	976	936	718	638	698	738	453	513	553
MBGR 1002 T4 37kW	976	936	718	638	698	738	453	513	553
MBGR 1003 T6 7,5kW	976	936	718	638	698	738	453	513	553
MBGR 1004 T6 11kW	976	936	718	638	698	738	453	513	553
MBGR 1121 T4 45kW	1084	1037	793	715	775	815	507	567	607
MBGR 1122 T4 55kW	1084	1037	793	715	775	815	507	567	607
MBGR 1123 T6 15kW	1084	1037	793	715	775	815	507	567	607
MBGR 1124 T6 18,5kW	1084	1037	793	715	775	815	507	567	607
MBGR 1251 T4 75kW	1214	1163	898	801	871	921	569	639	689
MBGR 1252 T4 110kW	1214	1163	898	801	871	921	569	639	689
MBGR 1253 T6 22kW	1214	1163	898	801	871	921	569	639	689
MBGR 1254 T6 30kW	1214	1163	898	801	871	921	569	639	689
MBGR 1401 T4 132kW	1325	1272	990	898	968	1018	638	708	758
MBGR 1402 T4 160kW	1325	1272	990	898	968	1018	638	708	758
MBGR 1403 T6 37kW	1325	1272	990	898	968	1018	638	708	758
MBGR 1404 T6 55kW	1325	1272	990	898	968	1018	638	708	758

Model	d	d1	d2	n1xp	n2xp	Ø3
MBGR 711 T2 37kW	455	497	535	2x125	3x125	20
MBGR 712 T2 45kW	455	497	535	2x125	3x125	20
MBGR 713 T4 4kW	455	497	535	2x125	3x125	20
MBGR 714 T4 5,5kW	455	497	535	2x125	3x125	20
MBGR 801 T2 75kW	505	551	585	2x125	3x125	20
MBGR 802 T2 90kW	505	551	585	2x125	3x125	20
MBGR 803 T4 7,5kW	505	551	585	2x125	3x125	20
MBGR 804 T4 11kW	505	551	585	2x125	3x125	20
MBGR 901 T2 132kW	565	629	665	2x160	3x160	20
MBGR 902 T2 160kW	565	629	665	2x160	3x160	20
MBGR 903 T4 15kW	565	629	665	2x160	3x160	20
MBGR 904 T4 22kW	565	629	665	2x160	3x160	20
MBGR 905 T6 4kW	565	629	665	2x160	3x160	20
MBGR 906 T6 5,5kW	565	629	665	2x160	3x160	20
MBGR 1001 T4 30kW	635	698	735	2x160	3x160	20
MBGR 1002 T4 37kW	635	698	735	2x160	3x160	20

Model	d	d1	d2	n1xp	n2xp	Ø3
MBGR 1003 T6 7,5kW	635	698	735	2x160	3x160	20
MBGR 1004 T6 11kW	635	698	735	2x160	3x160	20
MBGR 1121 T4 45kW	715	775	815	2x160	4x160	24
MBGR 1122 T4 55kW	715	775	815	2x160	4x160	24
MBGR 1123 T6 15kW	715	775	815	2x160	4x160	24
MBGR 1124 T6 18,5kW	715	775	815	2x160	4x160	24
MBGR 1251 T4 75kW	805	861	905	2x200	3x200	24
MBGR 1252 T4 110kW	805	861	905	2x200	3x200	24
MBGR 1253 T6 22kW	805	861	905	2x200	3x200	24
MBGR 1254 T6 30kW	805	861	905	2x200	3x200	24
MBGR 1401 T4 132kW	905	958	1005	3x200	4x200	24
MBGR 1402 T4 160kW	905	958	1005	3x200	4x200	24
MBGR 1403 T6 37kW	905	958	1005	3x200	4x200	24
MBGR 1404 T6 55kW	905	958	1005	3x200	4x200	24

Wiring diagram

DIAGRAM Nº 1

230/400V

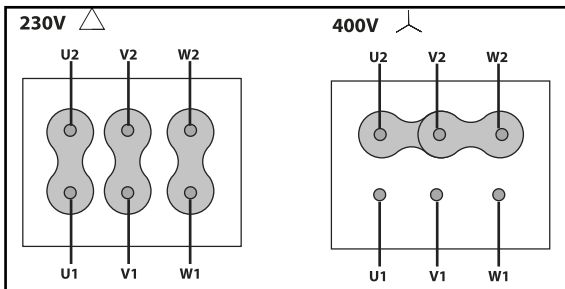

400/690V

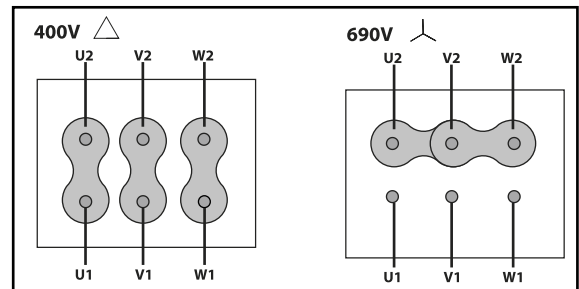

CHARACTERISCTIC CURVE

1	MBGR 401 T2 2,2kW	2	MBGR 402 T2 3kW	3	MBGR 451 T2 4kW	4	MBGR 452 T2 5,5kW
5	MBGR 501 T2 7,5kW	6	MBGR 502 T2 11kW	7	MBGR 561 T2 11kW	8	MBGR 562 T2 15kW

AIR FLOW - PRESSURE

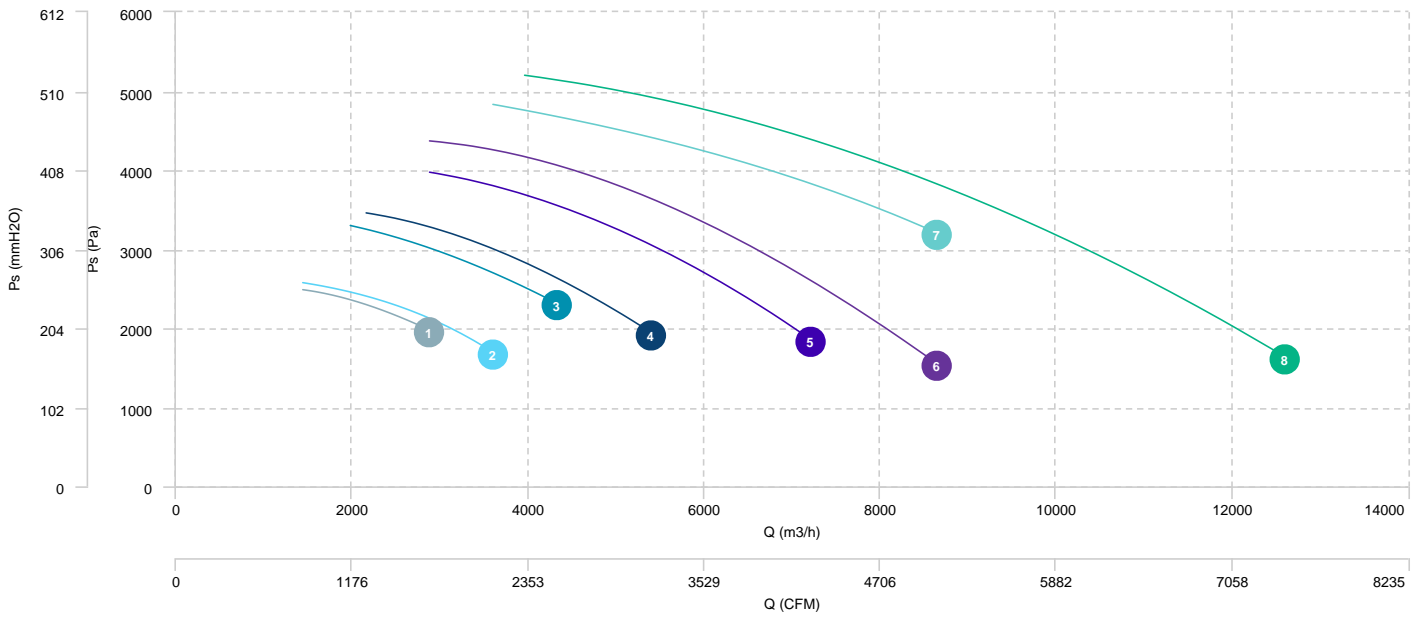

1	MBGR 631 T2 22kW	2	MBGR 632 T2 30kW	3	MBGR 711 T2 37kW	4	MBGR 712 T2 45kW
5	MBGR 801 T2 75kW	6	MBGR 802 T2 90kW	7	MBGR 901 T2 132kW	8	MBGR 902 T2 160kW

AIR FLOW - PRESSURE

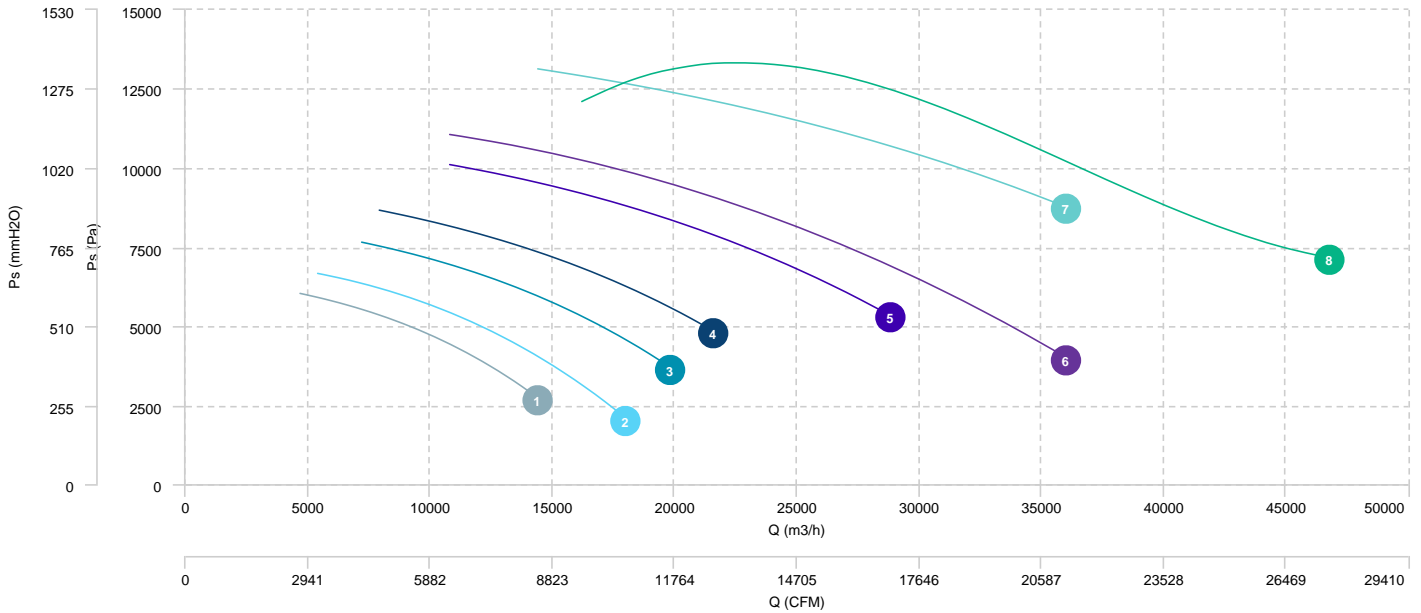

1	MBGR 563 T4 1,5kW	2	MBGR 564 T4 2,2kW	3	MBGR 633 T4 3kW	4	MBGR 634 T4 4kW
5	MBGR 713 T4 4kW	6	MBGR 714 T4 5,5kW	7	MBGR 803 T4 7,5kW	8	MBGR 804 T4 11kW
9	MBGR 903 T4 15kW						

AIR FLOW - PRESSURE

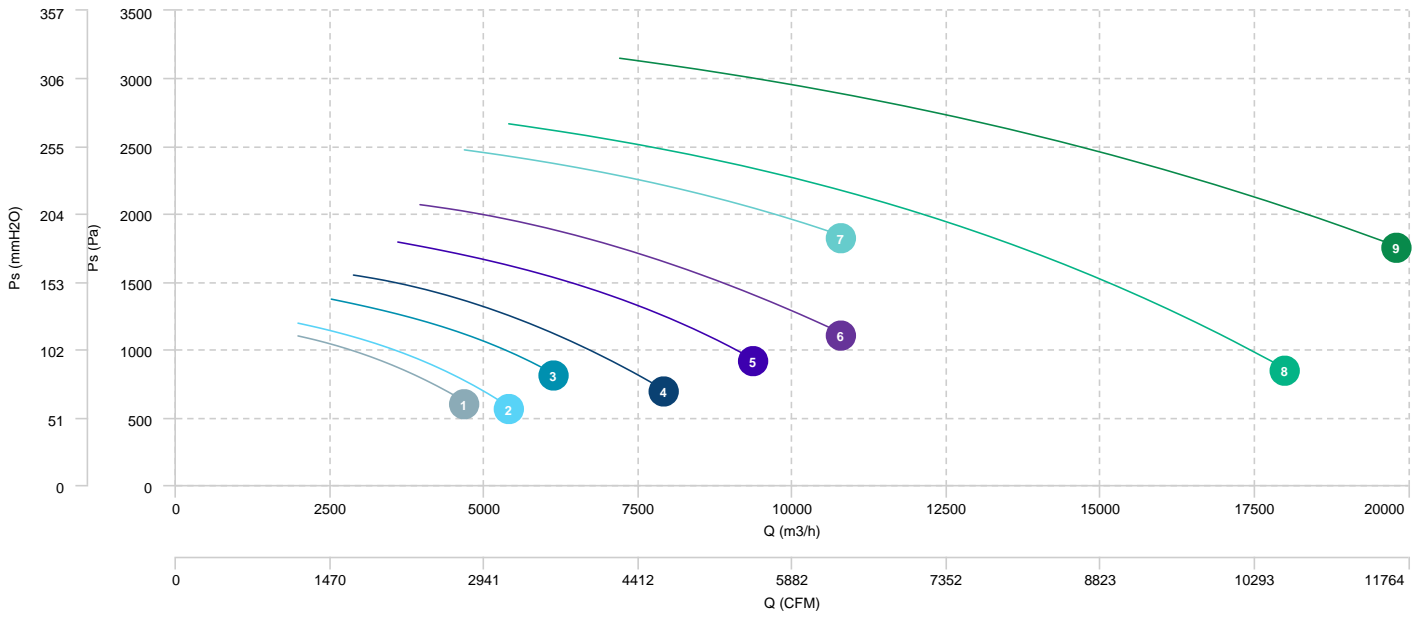

1	MBGR 904 T4 22kW	2	MBGR 1001 T4 30kW	3	MBGR 1002 T4 37kW	4	MBGR 1121 T4 45kW
5	MBGR 1122 T4 55kW	6	MBGR 1251 T4 75kW	7	MBGR 1252 T4 110kW	8	MBGR 1401 T4 132kW
9	MBGR 1402 T4 160kW						

AIR FLOW - PRESSURE

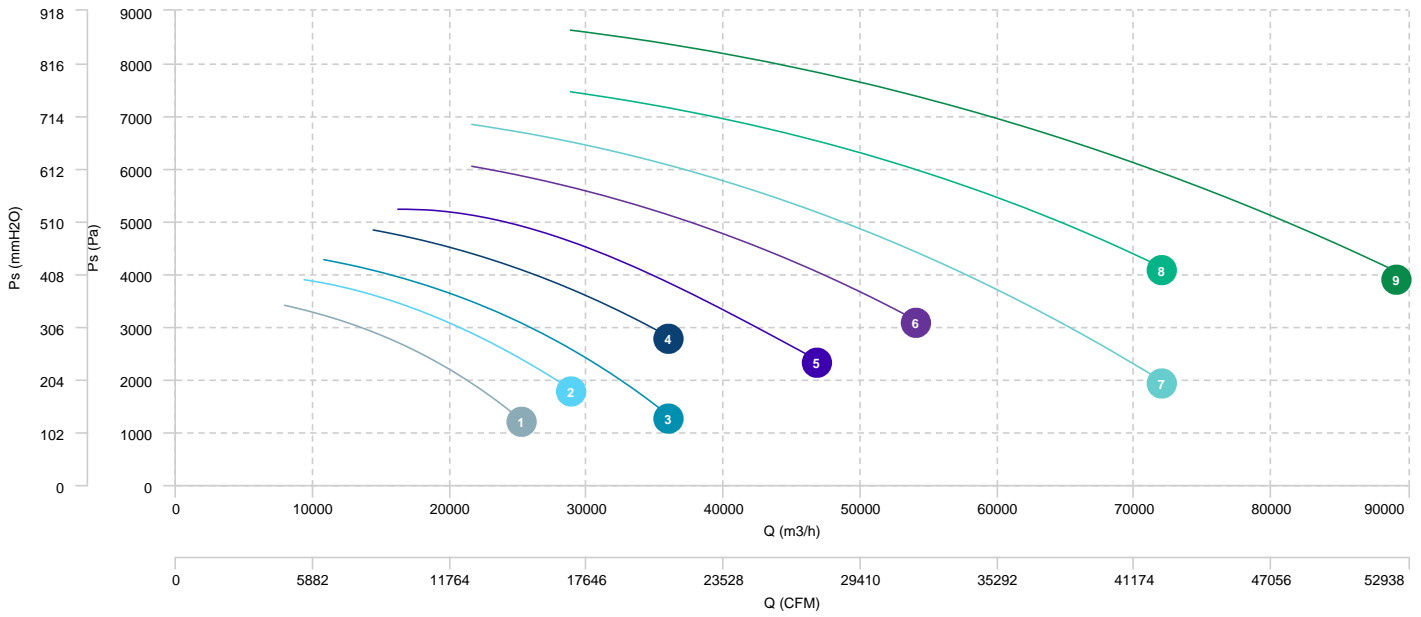

1 MBGR 905 T6 4kW	2 MBGR 906 T6 5,5kW	3 MBGR 1003 T6 7,5kW	4 MBGR 1004 T6 11kW
5 MBGR 1123 T6 15kW	6 MBGR 1124 T6 18,5kW	7 MBGR 1253 T6 22kW	8 MBGR 1254 T6 30kW
9 MBGR 1403 T6 37kW	10 MBGR 1404 T6 55kW		

AIR FLOW - PRESSURE

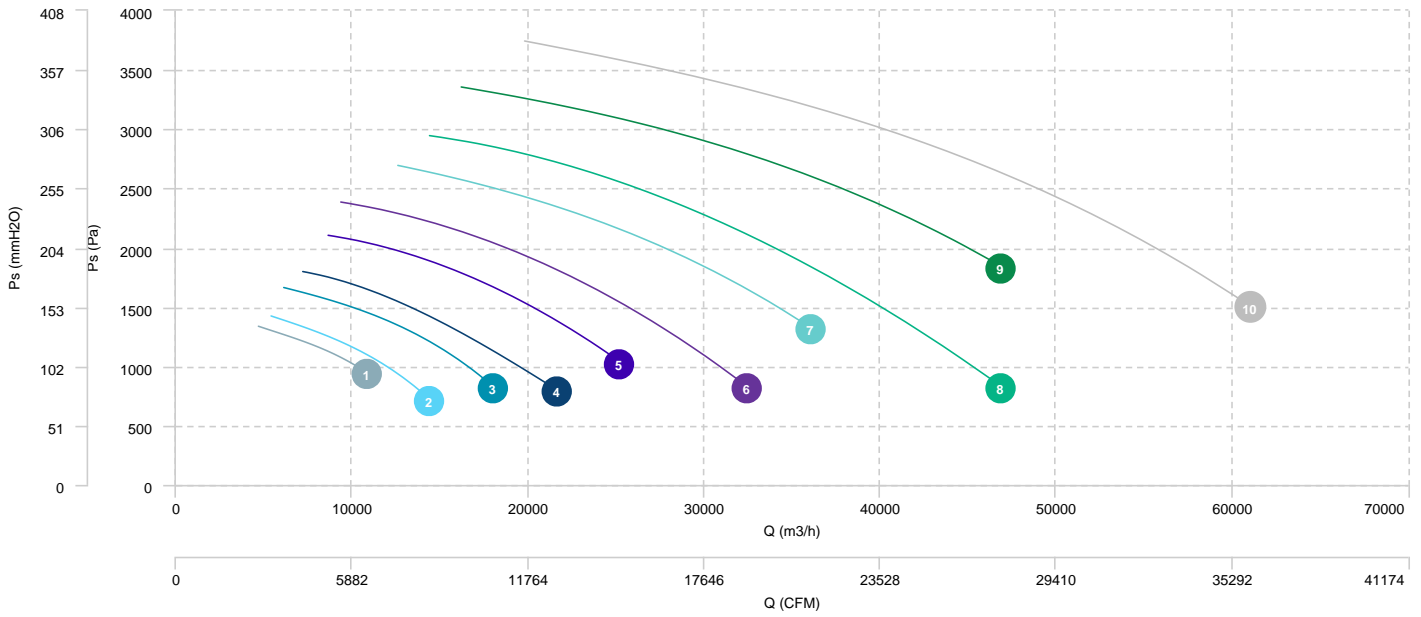

Sound data

Sound / 2 poles

		Sound power Lw dB (A)								
Model		63 Hz	125 Hz	250 Hz	500 Hz	1000 Hz	2000 Hz	4000 Hz	8000 Hz	Total
MBGR 401 T2 2,2kW	Inlet	54	66	72	76	77	73	66	63	82
MBGR 402 T2 3kW	Inlet	57	69	76	80	81	76	70	67	85
MBGR 451 T2 4kW	Inlet	60	72	79	83	84	79	73	70	88
MBGR 452 T2 5,5kW	Inlet	65	77	83	87	88	84	77	74	92
MBGR 501 T2 7,5kW	Inlet	69	81	87	92	92	88	81	78	97
MBGR 502 T2 11kW	Inlet	70	82	89	93	94	89	83	80	98
MBGR 561 T2 11kW	Inlet	69	81	87	91	92	87	81	78	96
MBGR 562 T2 15kW	Inlet	73	85	91	95	96	91	85	82	100
MBGR 631 T2 22kW	Inlet	75	87	94	98	99	94	87	84	103
MBGR 632 T2 30kW	Inlet	76	88	95	99	100	95	88	85	104
MBGR 711 T2 37kW	Inlet	80	92	98	102	103	98	92	89	107
MBGR 712 T2 45kW	Inlet	80	92	99	103	104	99	93	90	108
MBGR 801 T2 75kW	Inlet	83	95	101	105	106	101	95	92	110
MBGR 802 T2 90kW	Inlet	84	96	102	106	107	102	96	93	111
MBGR 901 T2 132kW	Inlet	88	100	106	110	111	107	100	97	115
MBGR 902 T2 160kW	Inlet	90	102	108	112	113	109	102	99	118

Sound / 4 poles

		Sound power Lw dB (A)								
Model		63 Hz	125 Hz	250 Hz	500 Hz	1000 Hz	2000 Hz	4000 Hz	8000 Hz	Total
MBGR 563 T4 1,5kW	Inlet	51	63	70	74	75	70	64	61	79
MBGR 564 T4 2,2kW	Inlet	54	66	72	77	77	73	66	63	82
MBGR 633 T4 3kW	Inlet	56	68	74	79	79	75	68	65	84
MBGR 634 T4 4kW	Inlet	58	70	76	80	81	76	70	67	85
MBGR 713 T4 4kW	Inlet	60	72	79	83	84	79	73	70	88
MBGR 714 T4 5,5kW	Inlet	63	75	82	86	87	82	75	72	91
MBGR 803 T4 7,5kW	Inlet	63	75	82	86	87	82	76	73	91
MBGR 804 T4 11kW	Inlet	67	79	85	89	90	86	79	76	95
MBGR 903 T4 15kW	Inlet	66	78	84	88	89	84	78	75	93
MBGR 904 T4 22kW	Inlet	72	84	90	94	95	90	84	81	99
MBGR 1001 T4 30kW	Inlet	74	86	92	96	97	92	86	83	101
MBGR 1002 T4 37kW	Inlet	75	87	94	98	99	94	88	85	103
MBGR 1121 T4 45kW	Inlet	77	89	96	100	101	96	90	87	105
MBGR 1122 T4 55kW	Inlet	79	91	97	101	102	97	91	88	106
MBGR 1251 T4 75kW	Inlet	81	93	99	103	104	100	93	90	109

Sound power Lw dB (A)										
Model		63 Hz	125 Hz	250 Hz	500 Hz	1000 Hz	2000 Hz	4000 Hz	8000 Hz	Total
MBGR 1252 T4 110kW	Inlet	83	95	102	106	107	102	95	92	111
MBGR 1401 T4 132kW	Inlet	85	97	103	107	108	103	97	94	112
MBGR 1402 T4 160kW	Inlet	82	94	100	104	105	101	94	91	110

Sound / 6 poles

Sound power Lw dB (A)										
Model		63 Hz	125 Hz	250 Hz	500 Hz	1000 Hz	2000 Hz	4000 Hz	8000 Hz	Total
MBGR 905 T6 4kW	Inlet	53	65	71	75	76	72	65	62	81
MBGR 906 T6 5,5kW	Inlet	55	67	74	78	79	74	68	65	83
MBGR 1003 T6 7,5kW	Inlet	60	72	78	82	83	79	72	69	88
MBGR 1004 T6 11kW	Inlet	66	78	84	88	89	84	78	75	93
MBGR 1123 T6 15kW	Inlet	65	77	83	87	88	84	77	74	93
MBGR 1124 T6 18,5kW	Inlet	67	79	85	89	90	85	79	76	94
MBGR 1253 T6 22kW	Inlet	69	81	88	92	93	88	82	79	97
MBGR 1254 T6 30kW	Inlet	71	83	90	94	95	90	84	81	99
MBGR 1403 T6 37kW	Inlet	75	87	93	97	98	94	87	84	102
MBGR 1404 T6 55kW	Inlet	75	87	93	97	98	94	87	84	102